

ELECTRONIC INDUSTRIES



- ★ How Electronic Methods Are Speeding Tank and Plane Manufacture
- ★ What the Navy Requires of Radio Equipment
- ★ Broadcast and FM Practice. Short Wave Theory

JANUARY



Photo by U. S. Army Signal Corps

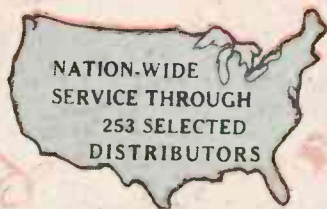

Mallory Helps Our "Hell Buggies" Kiss The Noise Good-Bye!



Communication between commanders and single units of an attacking column must not be "muddled" by the staccato zip-zip-zip of spark-plugs, electric motors, inverters or other man-made static within the zone of operations. So Mallory Noise Filters step in to suppress static and assure the clear communications that may mean the difference between success and failure . . . life or death.

On battlefronts in the air, on the sea and under the sea, Mallory Noise Filters are equally important . . . helping our fighters kiss the noise good-bye! On the home front, too, where clear radio reception is vital to Civilian Defense . . . and where static might guide enemy bombers to American targets, as has already occurred in Allied countries . . . Mallory Noise Filters help "keep 'em listening" in safety.

Noise filters, however, are just one of the many Mallory Approved Precision Products now serving in both military and industrial applications.

Condensers, rectifiers, Rectostarters, rheostats, volume controls, switches, jacks and plugs, vibrators and Vibrapacks . . . these and other Mallory parts are doing a job where conditions are toughest.

If you need electronic parts . . . for laboratory or test work, for replacements in existing equipment, or as elements in some new device . . . call on your nearest Mallory Distributor. There are 253 Mallory Distributors from coast to coast, ready to serve you promptly. Ask your Mallory Distributor, too, for your free copy of the latest Mallory Catalog . . . used as a buying guide in the aeronautical, automotive, electrical, geophysical, radio and other essential industries.



Write today for your Mallory Distributor's name, and for your copy of this useful catalog.



P. R. MALLORY & CO., Inc.

INDIANAPOLIS, INDIANA • Cable Address—PELMALLO

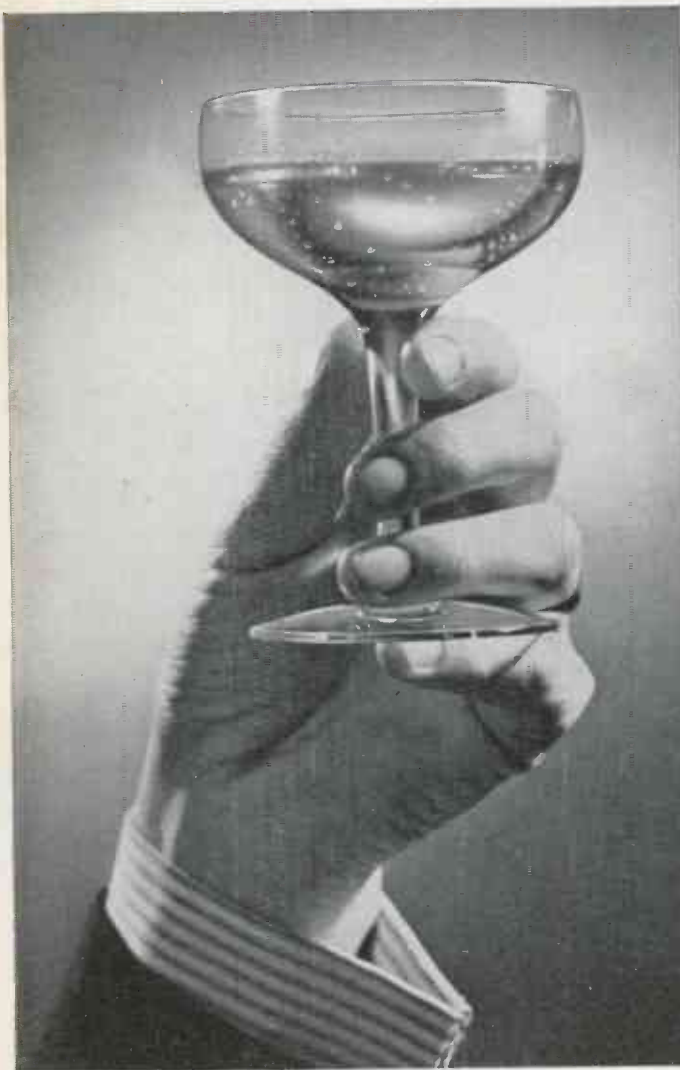

HERE'S TO LONG LIFE!

This TOBE PLUG-IN CAPACITOR — Type PTSC-2—is a refinement of the plug-ins originated over seven years ago by Tobe engineers. It has quite a history—and quite a future, too. In engineering and design, we have one primary objective—to assure *long and satisfactory life* for this and *all* Tobe capacitors under *all* operating conditions. And the testimony of

users of Tobe Capacitors proves that this objective is being reached.

Fortunately, too, to help war production requirements, we now have *additional complete* capacitor manufacturing facilities in operation, meeting urgent production needs. We invite discussion of *your* capacitor problems.

TOBE FILTERMITE (TYPE PTSC-2)

A refinement of early "plug-ins"—wax impregnated, hermetically sealed (also available in oil). Passes all required Army and Navy immersion tests. Low power factor.

CAPACITY: 2 x 8 microfarads

RESISTANCE: 2000 megohms per mfd.

VOLTAGE: 600 volts D. C. continuous working.

Individually tested at 1800 volts D. C.

(Available in 4 and 6-prong base)



THE HOUSE OF "3-PLUS" MANUFACTURE

The quality of Tobe Capacitors is unquestioned; a direct result of...

1. PERSISTENCE in Research
 2. SOUNDNESS in Engineering
 3. EXCELLENCE in Production
- PLUS... 15 years of Condenser Experience.



A heavy responsibility rests on all men in war industries . . . especially upon executives and engineers.

Their knowledge of confidential operations should not be the subject of discussions beyond the confines of the plant . . . nor should their natural pride in accomplishments cause them to speak unthinkingly. Discretion is an essential part of war production.

AMPEREX ELECTRONIC PRODUCTS
79 WASHINGTON STREET
BROOKLYN, NEW YORK

FOR HIGH-FREQUENCY POWER SOURCES

LAPP GAS-FILLED CONDENSERS

In any electronic circuit, wherever lump capacitance is needed, Lapp condensers will save space, save power and save trouble. Available for duty at almost any conceivably-useable voltage rating and capacitance, they bring to any application notable mechanical and electrical advantages: practically zero loss, smallest space requirement, non-failing, puncture-proof design, constant capacitance under temperature variations. *Shown, at left, Unit No. 25934, rated at 200 amp., 6500 volts, capacitance variable 4300 mmf. to 11000 mmf.; right, Unit No. 23722, rated at 50 amp., 7500 volts, capacitance 45 mmf. to 75 mmf.*



STANDOFF, BOWL, ENTRANCE INSULATORS

Standoff, bowl, entrance and other special-purpose insulators are available in wide range as standard Lapp catalog items. Other insulators of special design are easily produced by Lapp methods, either in porcelain or steatite. The wide choice of such insulators available from Lapp simplifies the design of high-frequency equipment. Also, Lapp is equipped for production of many special assemblies, of porcelain or steatite, and the associated metal parts.



LAPP PORCELAIN WATER COILS

For cooling of high-frequency tubes in radio transmitters and other electronic power sources, Lapp porcelain water coils have been widely used. With nothing about the porcelain to deteriorate, sludging is eliminated, and with it the need for cleaning and water changes. Porcelain pipe and fittings in any needed size are also available as catalog items. We welcome inquiry on any Lapp equipment for experimental or industrial electronic application.



Lapp

INSULATOR CO., INC.
LEROY, N. Y.





We are proud that THORDARSON helped win the first two, and now our 47 years of experience has gone "all out" to help win this war! THORDARSON research engineers are working 'round the clock . . . constantly seeking new methods for greater transformer efficiency.

When we have won this war and returned to our normal industrial life . . . THORDARSON engineers will be in possession of priceless knowledge which will be incorporated in THORDARSON products.

Your transformer problems will be welcomed by THORDARSON engineers . . . let them help you!

THORDARSON

ELECTRIC MFG. COMPANY
500 WEST HURON STREET, CHICAGO, ILLINOIS

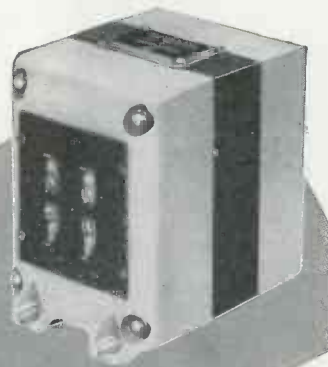

Transformer Specialists Since 1895

ELECTRONIC INDUSTRIES

JANUARY 1943

In this Issue

	Page
FRONT COVER—Uncle Sam's Newest M-4 Tanks, Radio-Equipped. Photo by Palmer of OWI	
CHART SUPPLEMENT—Fundamentals of Sound. Compiled in cooperation with Bell Telephone Laboratories.	
Editorial—"Remember Pearl Harbor"	33
Volume x Velocity equals Victory!	34
Tank Production Aided by Electronic Methods.	40
What the Navy Requires of Radio	42
Electronic Devices Speed Aircraft Production.	45
Snowstorm Shifts Radio Beam	47
Specifications for Ceramics.	48
Radio-Frequency Heating of Aircraft Parts.	50
Parts for Civilian Sets	53
RMA Engineering Dept. Concentrates on War.	54
Factory Short Cuts	56
Tributes to Dr. Wheeler, President IRE	58
New UHF Landing System at LaGuardia	62
50-kv FM at W55M	66
Principles of Short-Wave Radiation—I.	69
BC Operating Methods	74
Electronic Tubes on the Job	76
What's New	78
New Patents Issued	82
Association News	86
News from Washington	89
New Tubes	90
New Books	98
New Literature	99

Electronic Industries, January, 1943, Vol. II, No. 1. 35 cents a copy. Published monthly by Caldwell-Clements, Inc., 480 Lexington Avenue, New York, N. Y. M. Clements, President; Orestes H. Caldwell, Treasurer.

Subscriptions: Continental United States only, \$3 for one year; \$5 for two years. Printed in U.S.A. Acceptance under the Act of June, 1934, authorized November 10, 1942. Copyright by Caldwell-Clements, Inc., 1942.—Printed in U.S.A.

ORESTES H. CALDWELL
Editor

M. CLEMENTS
Publisher

EDITORIAL STAFF

William Moulie Gilbert R. Sonberg
Frank E. Butler Joseph Zentner Jean Mayer
Ralph R. Batcher, Consulting Editor
Roland C. Davies, Washington Editor

BUSINESS STAFF

M. H. Newton John A. Samborn
B. V. Spinetta W. W. Swigert
J. E. Cochran G. J. Wick

CHICAGO 201 N. Wells St. R. Y. Fitzpatrick
Telephone RANdolph 9225

Editorial and Executive Offices
Telephone Plaza 3-1340
480 Lexington Avenue
NEW YORK

➔ ← **SHORTCUT** to an improved product..

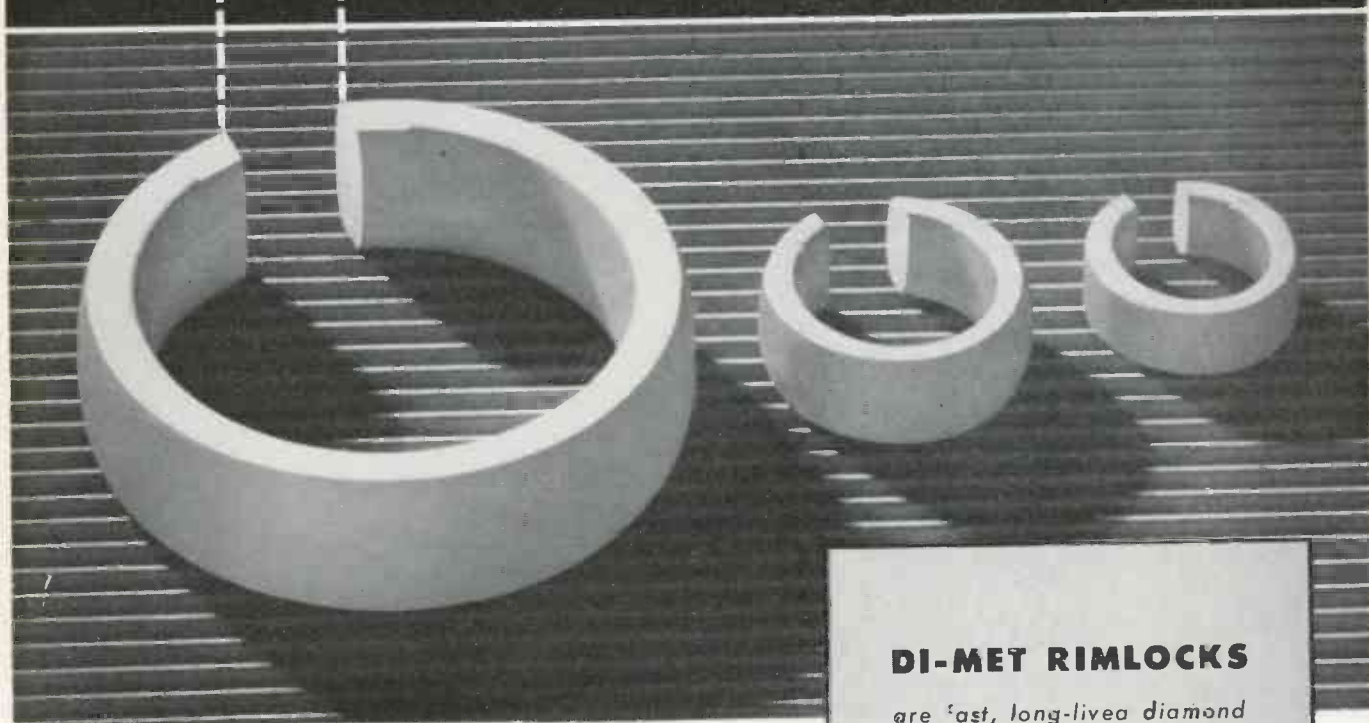

MANY manufacturers are finding it simpler, faster and cheaper to cast Steatite to shape and cut away webs, fins or other manufacturing necessities with a Di-Met Diamond Abrasive Wheel. An example is this Steatite form. Formerly diecast with a small connecting web between the two open ends, warping during firing caused a high number of rejects. The problem was finally solved simply by casting the circular piece complete, then removing a section with two Di-Met blades properly spaced on a single spindle and operated as a gang cutter. Warping was completely absent, rejects practically eliminated, die cost lowered, and production improved! Perhaps you can effect a similar short-cut in your manufacturing methods by using a Di-Met blade to cut any hard, brittle non-metallic material. Send your samples for trial cutting.

DI-MET RIMLOCKS
are fast, long-lived diamond abrasive cutters and are rendering outstanding performance wherever brittle materials must be cut. They're available in copper and steel bonds, in sizes for all applications. Rimlocks are extensively used to cut ceramic or vitrified products such as porcelain, tile, clay products, glass, quartz, non-laminated plastics, marble, glazed face brick, etc.

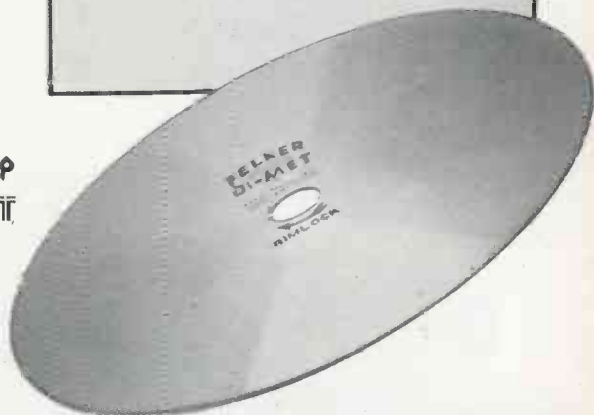

FELKER MANUFACTURING CO.
Border Street at Torrance Boulevard, Torrance, Calif.

MANUFACTURERS OF DIAMOND ABRASIVE WHEELS

NEW THINGS.



ARE COMING *Fast!*

IN laminated plastic materials, as in so many others, the new conditions imposed by war have led to intensified research which has developed new products and new qualities that are certain to be valuable after the war.

Formica, with the assistance of customers and suppliers, has had a share in this progress. Some of the new things: laminated plastic name plates, glass cloth base insulating material to serve some of the uses of ceramics; arc resistant insulation, "Pregwood", a light, strong, impregnated wood that serves many mechanical uses, and fluorescent instrument panels visible in the dark.

When the war is over let us tell you about the new things in Formica that might serve you better.



THE FORMICA INSULATION COMPANY, 4647 SPRING GROVE AVE., CINCINNATI, OHIO

HEADQUARTERS FOR ACCURATE, INFORMED Local Order Service

Your local RCA Tube and Equipment Distributor is headquarters for the following items, and, equally important, for the all-essential "know how" of their application and use:

RCA, CUNNINGHAM, and RCA VICTOR RADIO TUBES
RCA SPECIAL PURPOSE TUBES, POWER TUBES,
PHOTOTUBES, CATHODE RAY TUBES etc.
RCA ELECTRONIC TEST EQUIPMENT

... also condensers, resistors, rheostats, controls, potentiometers, coils, wire, and numerous other radio and electronic components produced by many manufacturers.



OVER 300 RCA TUBE AND EQUIPMENT DISTRIBUTORS

...TO SERVE YOU LOCALLY!

WHETHER your need is for one electronic item or a dozen, your RCA Tube and Equipment Distributor is geared to help you select it and get it as rapidly as possible! The fact that there are over 300 of these distributors throughout the nation means that there is one close by—ready to deliver personalized, 'round-the-corner service.

RCA Tube and Equipment Distributors not only afford a convenient, 'round-the-corner source of supply, but back their merchandise

with a technical knowledge that has proved invaluable.

If you do not already know the name of your nearest RCA Distributor, write or wire us today.

Put his services to work in solving your electronic equipment buying problems. Take advantage of the large stocks he normally maintains. Let him serve as your specialized "expediter" on orders that must be deferred. Ask him for the technical suggestions he is so well qualified to give!
RCA MANUFACTURING CO., INC., Camden, N. J.



AN ADVERTISEMENT OF THE RCA TUBE AND EQUIPMENT DIVISION IN THE INTEREST OF
GREATER SERVICE AND EFFICIENCY IN PRIORITY-COVERED WAR MATERIALS BUYING

THERE'S A LORD MOUNTING

BONDED RUBBER

TO KEEP

HARMFUL VIBRATION

FROM

EVERY *Electronic* DEVICE

TO keep mechanical and electrical equipment operating at peak efficiency and also prolong its operating life are factors of prime importance in today's program of high speed, precision production. Lord's contribution toward this end is the development of a series of Shear Type Bonded Rubber Mountings, particularly adaptable to electronic equipment.

Lord Mountings are made in two main types, Plate Form and Tube Form, and in load capacities ranging from a few ounces up to 1500 pounds. Due to the Lord method of bonding rubber to metal, the rubber, when loaded on main axis, is stressed in free shear. This design for free shear softness in the direction of the disturbing forces, results in an exceptional reduction in the natural frequency of the mounted system. Where very delicate, sensitive equipment is to be protected, the use of double or series mountings is recommended, thereby doubling the axial softness, and increasing the lateral softness. Lateral softness may be varied by changing the length of connection between mounting units. Double mountings give ideal protection where disturbing vibratory forces emanate from more than one direction.

No intricate layout, no special tooling or close machining is necessary to accommodate Lord Mountings. Properly installed, they absorb sudden shock and undue stresses, isolate harmful vibration and eliminate noise translated through solid conduction, all of which prolong equipment life and keep it operating at maximum efficiency. Regardless of size or weight there is a Lord Mounting for every electronic device. Send for Bulletins 103 and 104 on Lord Shear Type Mountings, or better still, call in a Lord vibration engineer for consultation on your design problems. There is no obligation.

LORD MOUNTINGS

PROLONG EQUIPMENT LIFE by isolating vibration, which reduces metal fatigue, thereby preventing subsequent failure.

INCREASE PRODUCTION by eliminating the necessity for close machining and precision alignment.

SAVE VITAL MATERIAL by reducing equipment weight; heavy inertia masses of machinery bases can be eliminated.

INCREASE PERSONNEL EFFICIENCY by eliminating nerve wearing noise and vibration, translated through solid conduction.

LOWER MAINTENANCE COSTS by protecting equipment against sudden load shocks and stresses, thereby minimizing repair and replacement operations.

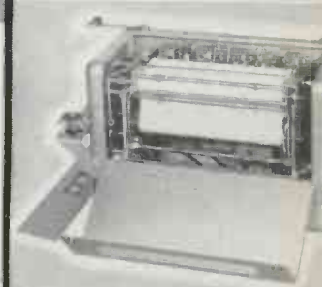

TYPICAL INSTALLATION

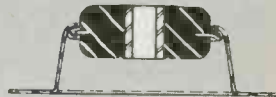

HOLDER TYPE

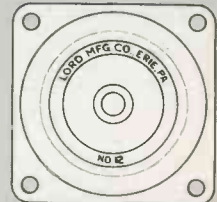

V. S. PLATE FORM



TUBE FORM

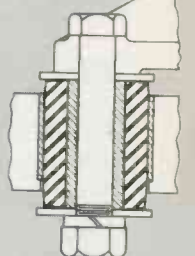

V. S. TUBE FORM

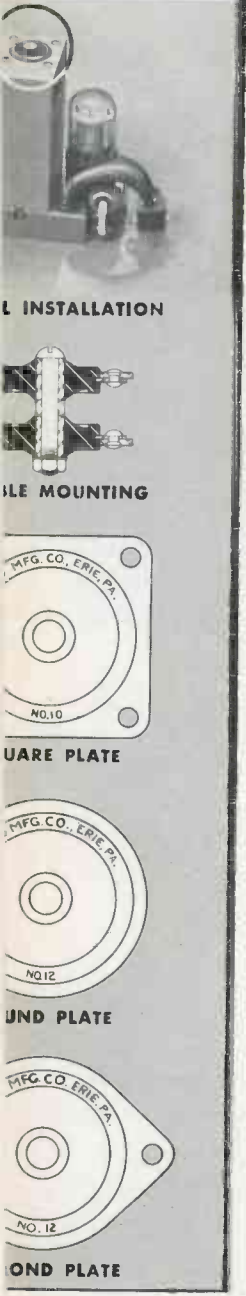

INSTALLATION

SQUARE PLATE

ROUND PLATE

ROUND PLATE

ORIGINATORS OF SHEAR TYPE BONDED RUBBER MOUNTINGS

LORD MANUFACTURING COMPANY... ERIE, PA.

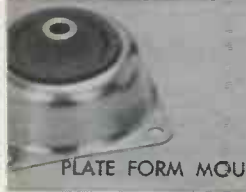
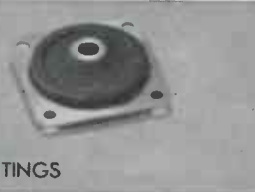

PLATE FORM MOUNTINGS



LORD

BONDED RUBBER
SHEAR TYPE
VIBRATION
MOUNTINGS



TUBE FORM MOUNTINGS

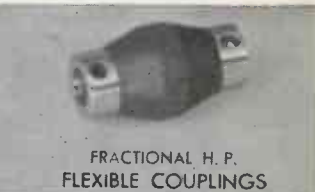

FRACTIONAL H. P.
FLEXIBLE COUPLINGS

REPRESENTATIVES . . . NEW YORK, 280 Madison Ave. . . CHICAGO, 520 N. Michigan Ave. . . BURBANK, CAL., 245 E. Olive Ave.

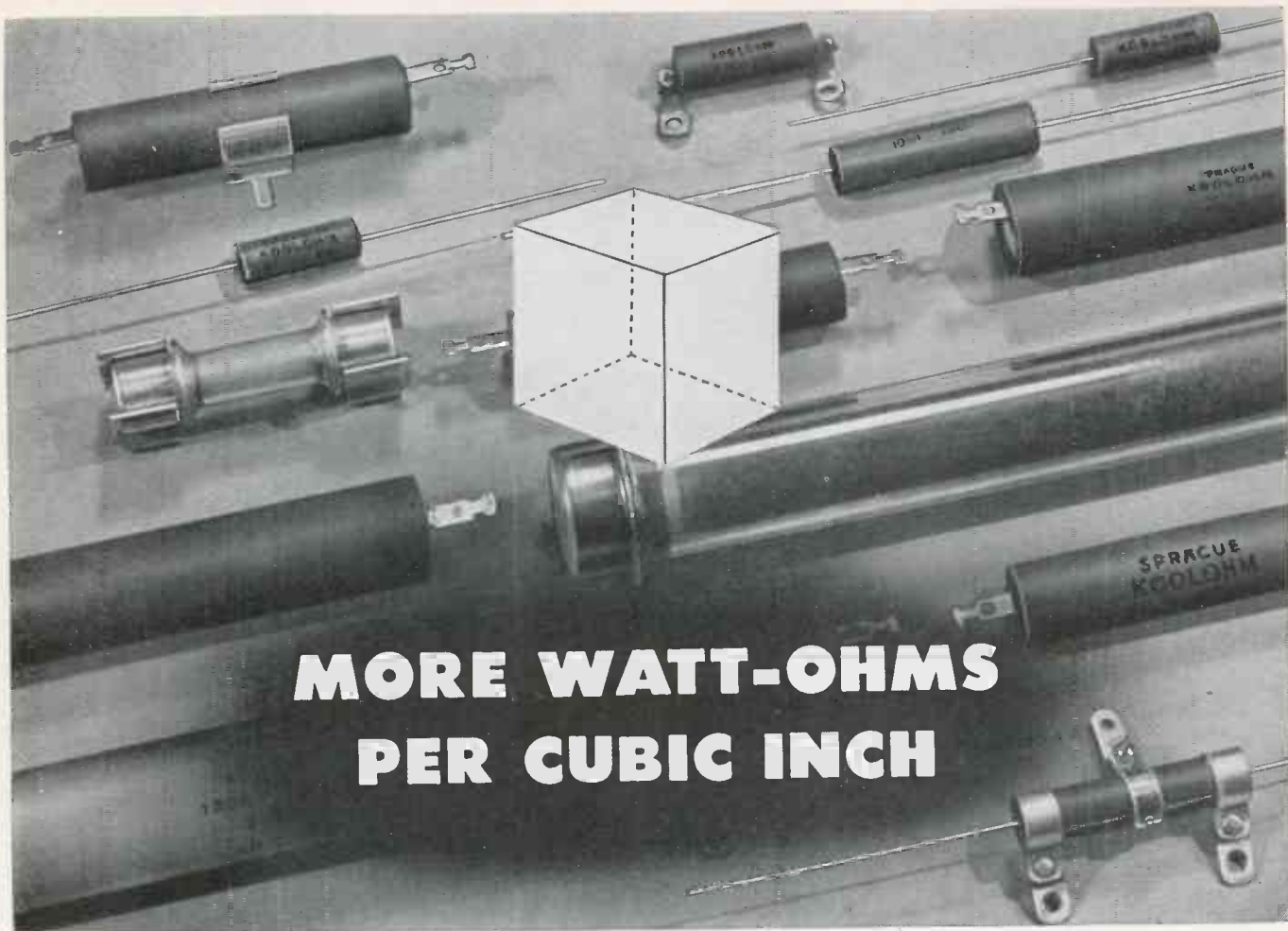

MORE WATT-OHMS PER CUBIC INCH

... greater dependability ... easier mounting ... less weight

Yes, Mr. Engineer, this is an odd, non-standard technical term—but it is one easily understandable, and certainly one that best explains the tremendous advantages obtained with Koolohm Resistor construction.

... For Koolohms provide the highest wattage ratings and resistance values in a given volume, with safe resistance wire sizes.

... Moreover, Koolohms deliver their full wattage ratings regardless of resistance values.

... Koolohms can be mounted easier and quicker and in less space—directly to the chassis or to grounded parts.

... Koolohms give a big, extra measure of depend-

ability on the high resistance values by using larger wire (2 1/4 times the cross-sectional area of that used by other manufacturers for these same values).

Koolohms are made with wire that is insulated before it is wound. This insulation is a special ceramic material having a dielectric strength of 350 volts per mil. at 400° C. It is heat-proof to 1000° C; fully moisture-proof, and so flexible it can be wound on small forms, either in short-proof layer-windings, or in high-density progressively-wound interleaved patterns.

Write today for the complete Sprague Koolohm Catalog and sample resistors.

SPRAGUE SPECIALTIES COMPANY
(Resistor Division) North Adams, Mass.

CONVENTIONAL

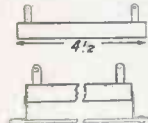

KOOLOHMS

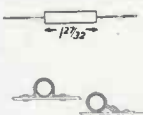

COMPARE!

Here is an actual comparison between a Sprague Koolohm resistor and a conventional wirewound!

Conventional	Specifications	Koolohm
2.5 mil. minimum	Limiting Wire Size	2.5 mil. minimum
10 watts, 7500 ohms	Rating	10 watts, 7500 ohms
4 1/2"	Length	1 27/32"
1 1/16"	Diameter	7/16"
40 grams	Weight	14 grams
Must not come in contact with chassis or grounded parts	Mounting (see above illustration)	Can be mounted flat on chassis or to grounded parts

SPRAGUE

KOOLOHM

WIRE-WOUND RESISTORS



A Wire Wound Resistor Isn't Modern UNLESS It's Wound with CERAMIC INSULATED WIRE!



YANKS IN AXIS PRISON CAMPS COULD TELL YOU...

how important it is to give war equipment maximum reliability. When blueprints call for capacitors... use Cornell-Dubilier.

IS THIS AMERICAN soldier thinking, they let me down? Thinking, I wouldn't be in this place if that stuff hadn't failed. "That stuff" could have been fighting equipment *you* were responsible for. Run no risk in vital war production... use C-Ds whenever the design calls for capacitors. Manufactured by specialists, Cornell-Dubilier capacitors have

that *extra* measure of stamina, performance, *reliability* needed in war operations. This capacitor dependability, born of Cornell-Dubilier's 33 years accumulated experience, may mean the difference between victory and — the concentration camp. Cornell-Dubilier Electric Corporation. So. Plainfield, New Jersey.

Since the materials used in the production of capacitors are under control, we are permitted to produce only against those orders carrying the necessary Preference Rating Extensions. Should you be unable to enjoy the finer performance of C-Ds now, we look forward to serving you when Victory has been won.



MICA TRANSMITTER CAPACITORS

The Mica Transmitter Capacitor Type 59, illustrated, is of improved design, extremely adaptable and has been proven dependable under the most severe operating conditions. Enclosed in low-loss, white glazed ceramic cases, with cast, low-resistance, wide-path end terminals. Can be mounted in any position, individually or in groups in series or parallel combinations. Type 59 Capacitors are described in Catalog No. 160T, free on request.

Cornell Dubilier capacitors



Mica • Paper • Dykanol • Wet & Dry Electrolytic Capacitors

M O R E I N U S E T O D A Y T H A N A N Y O T H E R M A K E



L A C E D W I R I N G H A R N E S S

F O R C O M M U N I C A T I O N S E Q U I P M E N T

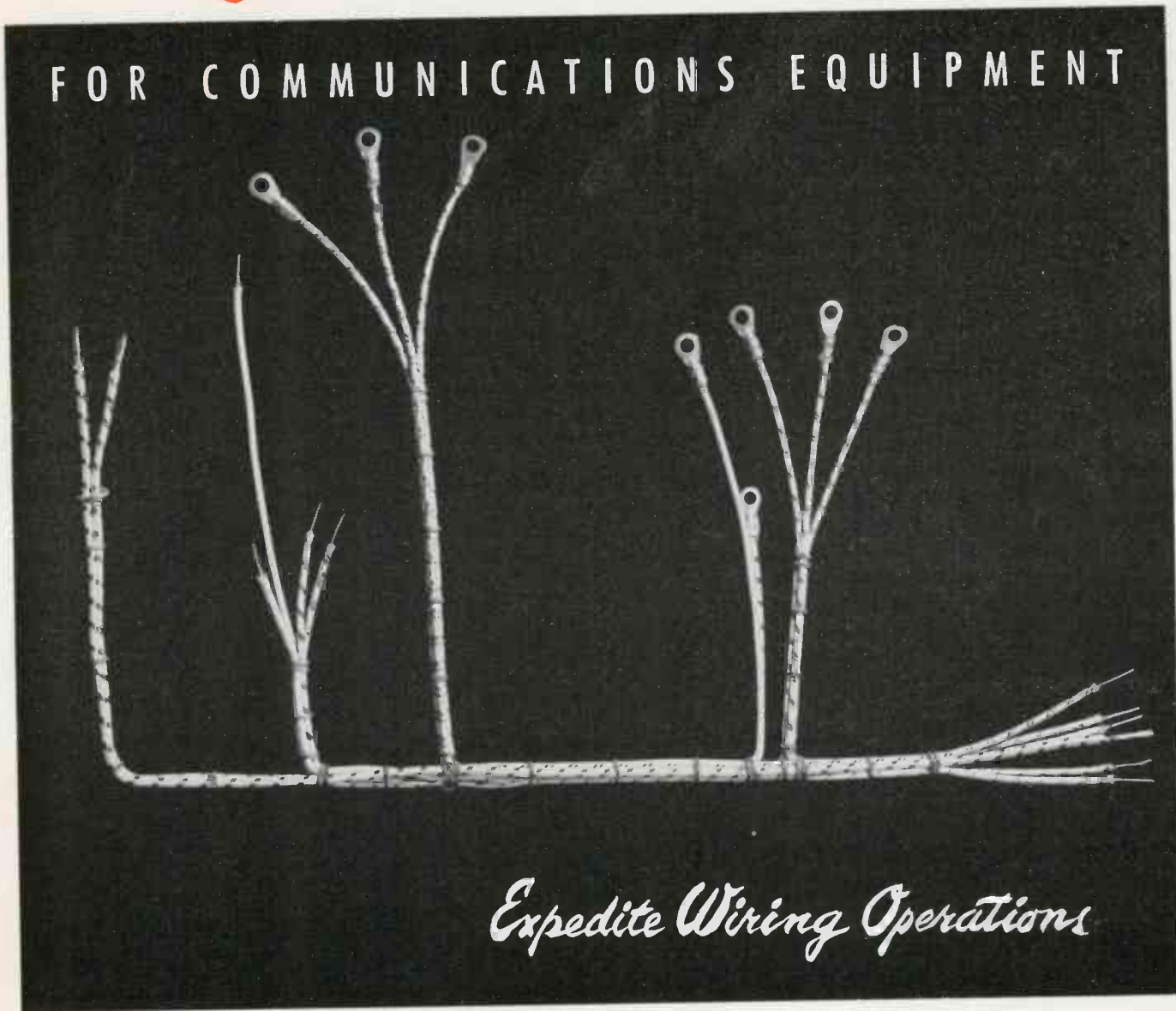

Expedite Wiring Operations

A sure cure for wiring "headaches." Constructed entirely of wires with approved types of color coded insulation, assembled exactly in accordance with your specifications, Lenz Laced Wiring Harnesses will speed up your wiring operations and permit the

release of some of your labor to other assembly tasks.

Make the Lenz organization a part of your factory. A Lenz Wire engineer will be glad to consult with you on your requirements. Quotations will be gladly furnished on receipt of specifications and sketch.



IN BUSINESS

SINCE 1904

LENZ ELECTRIC MANUFACTURING CO.

1751 NORTH WESTERN AVENUE • CHICAGO, ILLINOIS

NEW... a compact, high-capacity ceramic condenser

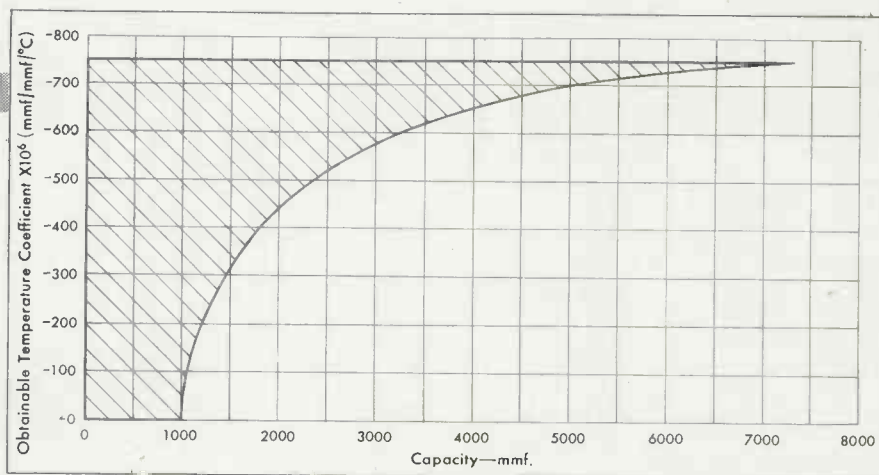
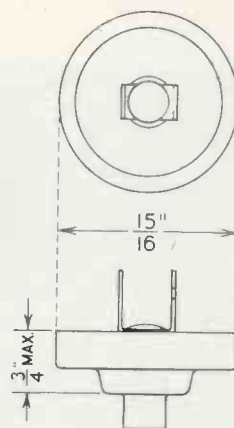
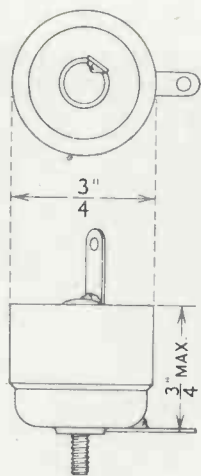

Erie

DISC CERAMICONS

REG. U. S. PAT. OFF.

THIS new, compact type of condenser consists essentially of a stack of thin ceramic discs, individually silvered and assembled in a metal cup.

Erie Disc Ceramicons have all the inherent properties of tubular Erie Ceramicons which have been used widely in many types of installations for over 6 years. These capacitors are extremely stable, have low loss and excellent re-trace characteristics. In addition, the units are very stable in humidity, as they are hermetically sealed.

Erie Disc Ceramicons are made in two sizes; $\frac{3}{4}$ " diameter rated at 500 volts D. C. and $\frac{15}{16}$ " diameter, rated at 1,500 volts D. C. The length of each style varies from

$\frac{1}{4}$ " to $\frac{3}{4}$ " depending on the capacity and temperature coefficient desired.

Present maximum available capacity of either type is approximately .007mfd. The accompanying chart shows the temperature coefficients available in various capacities of the $\frac{3}{4}$ " diameter unit.

Erie Disc Ceramicons have many applications in radio transmitters, receivers and other electronic equipment. They can be used as alternates for mica capacitors.

Inquiries for additional information should state: capacity and tolerance, temperature coefficient and tolerance, working voltage and frequency, type of mounting, and style of leads desired.

ERIE RESISTOR CORP., ERIE, PA. LONDON, ENGLAND · TORONTO, CANADA.

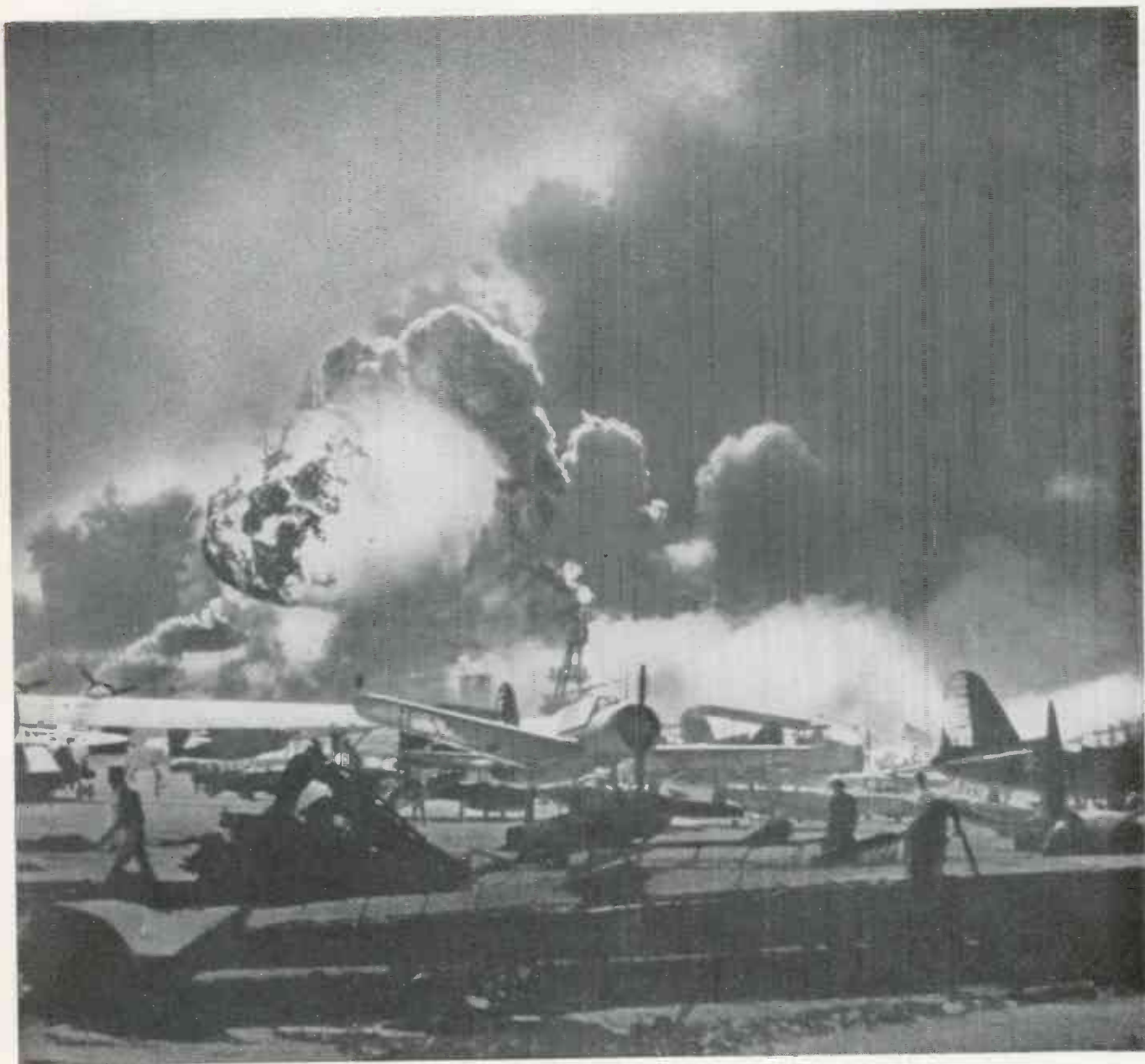

U. S. Navy Official Photo

Minus Sound Effects

If you were receiving radio broadcasts from men in the midst of ear-splitting battle noises, you'd hear crisp speech undistorted by background sound effects.

Electro-Voice Microphones, in military service, are helping to make it possible. Similar microphones, designed to achieve such results, will be available for specific commercial applications . . . after our wartime job is done.

Electro-Voice MICROPHONES

ELECTRO-VOICE MANUFACTURING CO., INC.

1239 SOUTH BEND AVENUE, SOUTH BEND, INDIANA

ELECTRONIC INDUSTRIES • January, 1943

43

RELAYS



FROM GUN BLAST HEAT

TO ARCTIC COLD

★ Smothered in dust . . . seared by gun blast heat . . . shrouded in fog . . . gripped by stratosphere cold . . . shaken by blasts of bomb and shell . . . these are daily incidents in the life of a relay. Under these conditions Relays by Guardian have already "proved their metal."

THE SERIES 195 RELAY weighs less than an ounce! But don't let its tiny size fool you. It shrugs off the most severe vibrations likely to be encountered in aircraft. And it's especially adaptable to jobs where space as well as weight is at a premium. It's about wrist watch size in length and width—and not a great deal thicker.

SERIES 345 RELAY. A radio relay for use in aircraft. Maximum contact combination of three pole, double throw, combined with large coil winding area makes this a highly efficient relay in compact space.

While thinking, building and engineering the tools of war today, Guardian is also looking ahead to peacetime applications of Relays, Solenoids, Electrical Controls of all kinds. If you are planning for the future too, write us—our war-time experience can help you build better peacetime products.

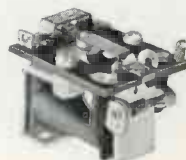

Series 195 Relay. One of the smallest relays made. Write for new Bulletin.



Series 345 Relay. For radio aircraft use. Write for new Bulletin.

GUARDIAN ELECTRIC

1622 WEST WALNUT STREET CHICAGO, ILLINOIS

A COMPLETE LINE OF RELAYS SERVING AMERICAN WAR INDUSTRY

Preview

OF TRIPLE CHECKED ACCURACY



YOU get a preview of your special steatite insulators when we make them — and a *triple check* on the accurate compliance with your blueprints and specifications.

We make and check the tools for fabricating your order. *Check number one.*

Samples produced for you with these tools get a complete inspection of every detail. *Check number two.*

Inspectors make a "Sample Report" which you

receive with the samples. The report states dimensions and drawing dimensions, actual dimensions and variations beyond tolerance, if any. Your *check number three* — after a preview of the product.

After your O.K., you can be sure that the rest of the order will conform to your specifications.

To the best of our knowledge, this service is unique in our field. It is one of the factors of our controlled manufacturing technique which assures quality and uniformity of product.

General Ceramics

AND STEATITE CORP.
KEASBEY NEW JERSEY



3548

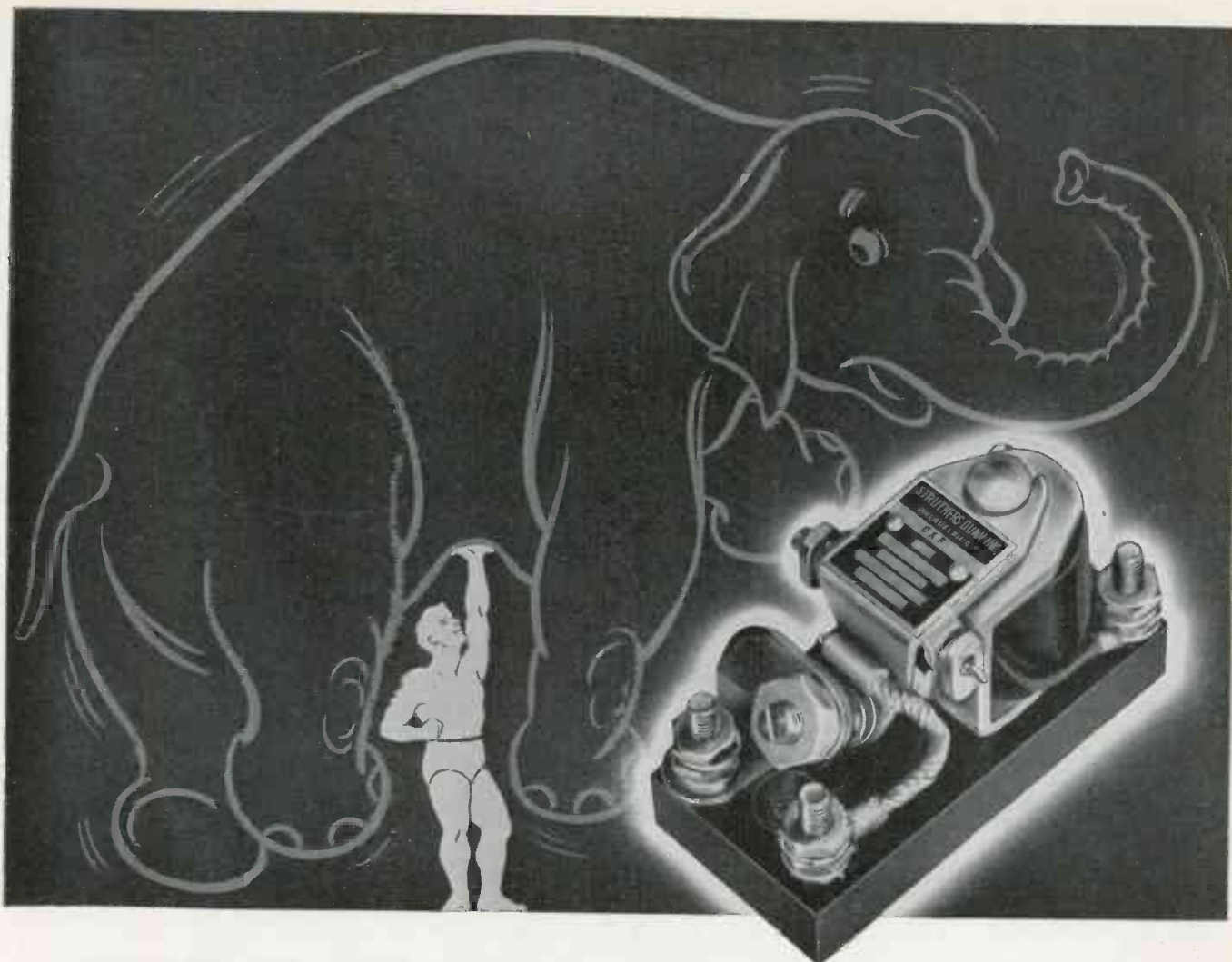

LITTLE GIANT of the RELAY FIELD

Contact Pressure Will Lift 15 Times the Weight of the Unit Itself!



WRITE FOR YOUR COPY!

Get your copy of the new Dunco Catalog and Data Book! Contains design and engineering information on the nation's most complete line of quality relays, timers and solenoids, plus helpful data on their selection and use.

Little Giant—Nutcracker—Bulldog...

Such are the names applied to the Dunco Series 61 D.C. Relays in recognition of their remarkable performance in the toughest applications from tanks to airplanes, steel mills or what have you.

For instance, ordinary relays weighing one pound may have a contact pressure of 3 or 4 ounces. This Dunco type gives *7 pounds contact pressure in a unit weighing only 8 ounces*—and is especially designed to withstand intense shocks or vibration and operate faithfully without an enclosure in dirty or dusty places!

Supplied on priority orders in various single and double pole types, these units are designed for D.C. use, although their contacts will also handle A.C. All types are recommended for any low voltage D.C. service where their exceptionally strong contact pressure is desirable for securing maximum resistance to shock.

DUNCO RELAYS AND TIMING DEVICES

STRUTHERS DUNN, INC., 1321 ARCH ST., PHILADELPHIA, PA.



IN the manufacture of precision instruments for the Armed Forces we strive for short cuts in production—but not in *quality*. There can be no expediency, no compromise, no half-way measures. The success of the bomber's mission depends as much upon the efficiency of the instruments as it does upon the skill of the officers and men.

Meeting the specifications of the United States Armed Forces

is in itself an eloquent testimonial to the *quality* of DeJur meters, potentiometers and rheostats. However, we do not rest upon these laurels alone. Behind DeJur workers is the stern tradition of New England . . . honesty of craftsmanship, pride of skill, the deep, personal delight in doing a job and doing it better than anyone else—anywhere.

in war as in peace . . . *nothing takes the place of quality.* Your inquiries are invited.



DeJUR-AMSCO CORPORATION

SHELTON, CONNECTICUT

Manufacturers of DeJur Meters, Potentiometers, Rheostats and other Precision, Quality Electrical Instruments

Ultra High-Frequency Research

Electronics

THIS APPLICATION IS REALLY NEW!

Radio Circuits Research Division

HOLD THIS FOR TELEVISION!
CVR

Amazing Application here will change records

Special Studies G

$$\begin{array}{r} 48 \times 426 \\ \times 611 \\ \hline \end{array} = x$$

MEMO

J. A. K.

There's something BIG for every Philco dealer after the War

Rky

A Brighter Tomorrow

WILL COME FROM WAR RESEARCH AND PRODUCTION TODAY

The electronic miracles which have been developed in the Philco laboratories and produced in the Philco factories have helped to bring the dawn of the *Age of Electronics* to the battlefronts of the world.

Yesterday, they were scientists' dreams. Today, they are realities. Tomorrow, their deadly purpose will be turned to the pursuits of peace. And, with Victory, the *Age of Electronics* will dawn for all humanity, bringing thrilling new wonders of comfort, convenience and entertainment.

PHILCO CORPORATION

OUR WAR PRODUCTION PLEDGE: More • Better • Sooner

Revolutionary Idea for a Refrigerator

Air Conditioning Laboratories

This Does It!
an AIR CONDITIONER for every room

AB

PROTEIN FOODS

STANCOR

PROFESSIONAL SERIES

PLATE TRANSFORMERS

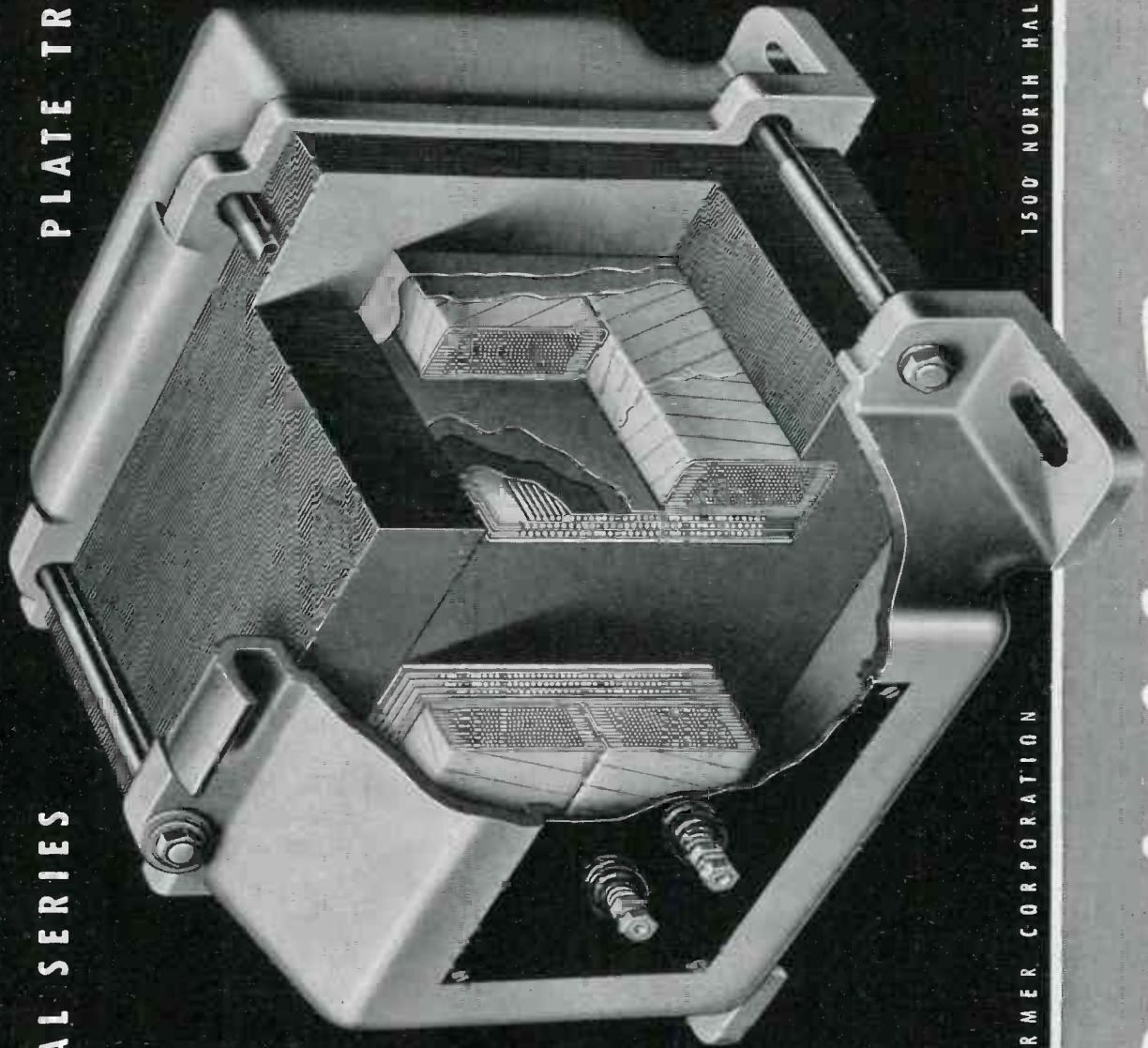

The best of insulating and conducting materials scientifically applied throughout the coil afford generous margins of safety against electrical failure.

Phenolic side panels with heavy duty insulating linings insure excellent dielectric characteristics and easy accessibility.

Cast semi-steel end bells provide a rugged mounting and a symmetrically finished appearance.

Accurately processed high grade silicon steel laminations, fully laminated, result in an efficient and low loss core structure.

Vacuum impregnation of coils and penetration of polishing compounds, furnish complete protection against the effects of humidity and time.

Rigid inspection of materials and progressive testing thru final fabrication result in a quality product.

STANDARD TRANSFORMER CORPORATION

1500 NORTH HALSIED STREET • CHICAGO



Built like a Battleship!

TRIPLETT

NEW *Combat Line* INSTRUMENTS

THESE PHOTOGRAPHIC REPRODUCTIONS ARE THREE-QUARTER SIZE

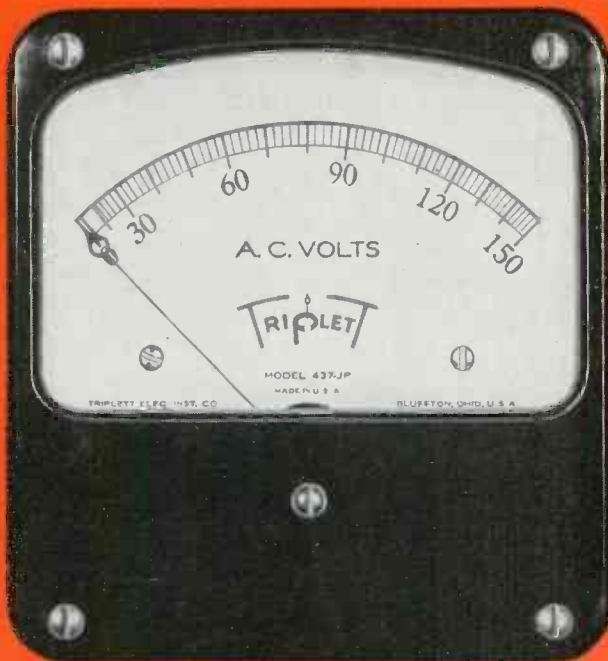

MODEL 437-JP

MODEL 372

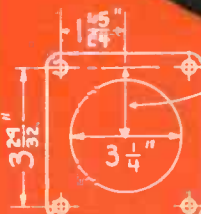
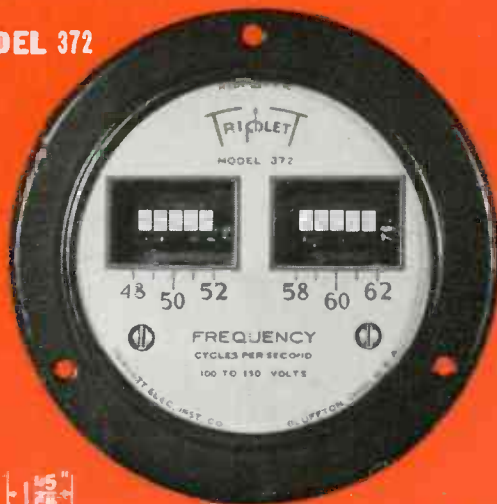

Model 437-JP

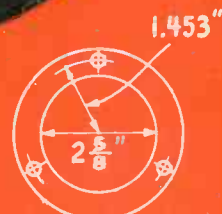

Model 372

SIMPLE
INSTALLATION
DIAGRAMS

Maximum Service in Minimum Space

TRIPLETT *Thin Line* INSTRUMENTS

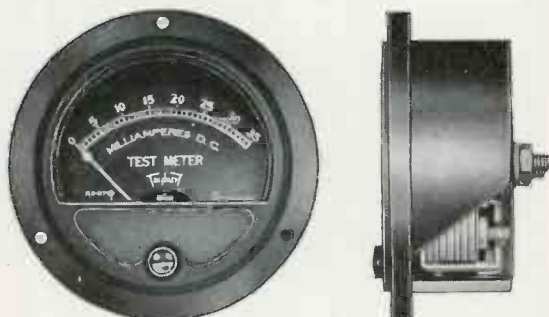

Precision performance by new *thin* instrument with *standard* Triplet movement housed in either metal or molded case. No projecting base; wider shroud to strengthen face; simplified zero adjustment; balanced bridge support; metal bridges at both ends; doubly supported core. For "Precision in limited space" write for Triplet Thin Line Bulletin.

The Triplet Combat Line

New Answers to specialized needs of War: Production, Speed-up and Standardization; Performance under the Stress and Vibrations of Combat Service.

Model 437 J P—A rectangular line of meters to meet dimensions shown (see diagram). Wide-open scale for maximum readability. Complete coverage AC-DC Voltmeters, Ammeters and Wattmeters. Magnetic or static shielding provided on order. Molded Plastic Case for maximum protection in high voltage circuits. Pivots, Jewels and other component parts designed to meet severe vibration requirements.

Model 372—Frequency Meter—"All-American make" Vibrating Reed Frequency Meter. Maximum readability by grouping of Reeds. Range-Frequency-Voltage to meet specific requirements. Protected against excessive panel vibration. In standard 3 inch mounting or on special order in any cataloged Triplet Case.

A WORD ABOUT DELIVERIES

Naturally deliveries are subject to necessary priority regulations. We urge prompt filing of orders for delivery as may be consistent with America's War effort.

TRIPLETT ELECTRICAL INSTRUMENT CO.
BLUFFTON, OHIO



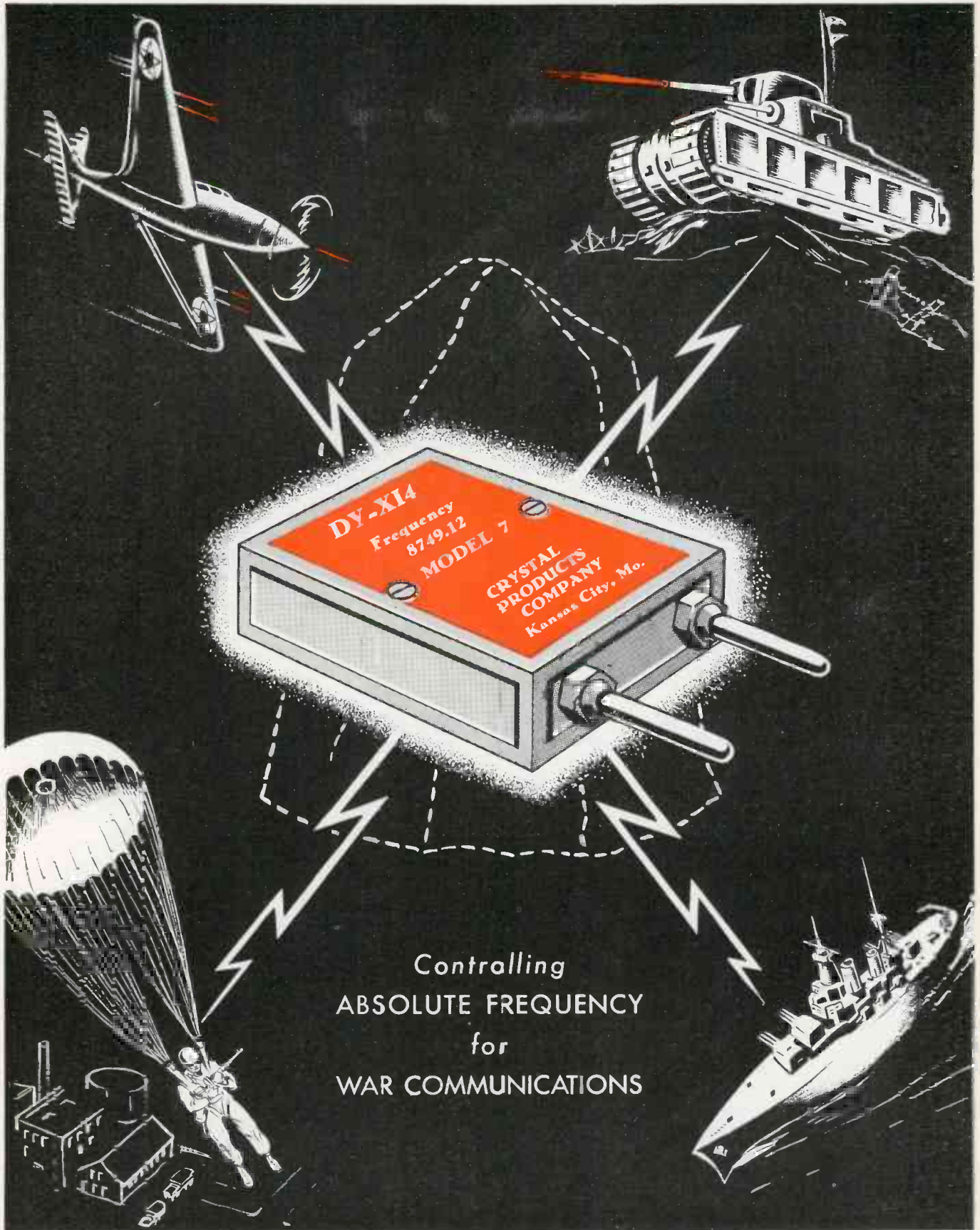

Controlling
 ABSOLUTE FREQUENCY
 for
 WAR COMMUNICATIONS



CRYSTAL PRODUCTS COMPANY

1519 McGee Street • Kansas City, Mo.

Producers of
 APPROVED
 PRECISION CRYSTALS
 for
 RADIO FREQUENCY
 CONTROL

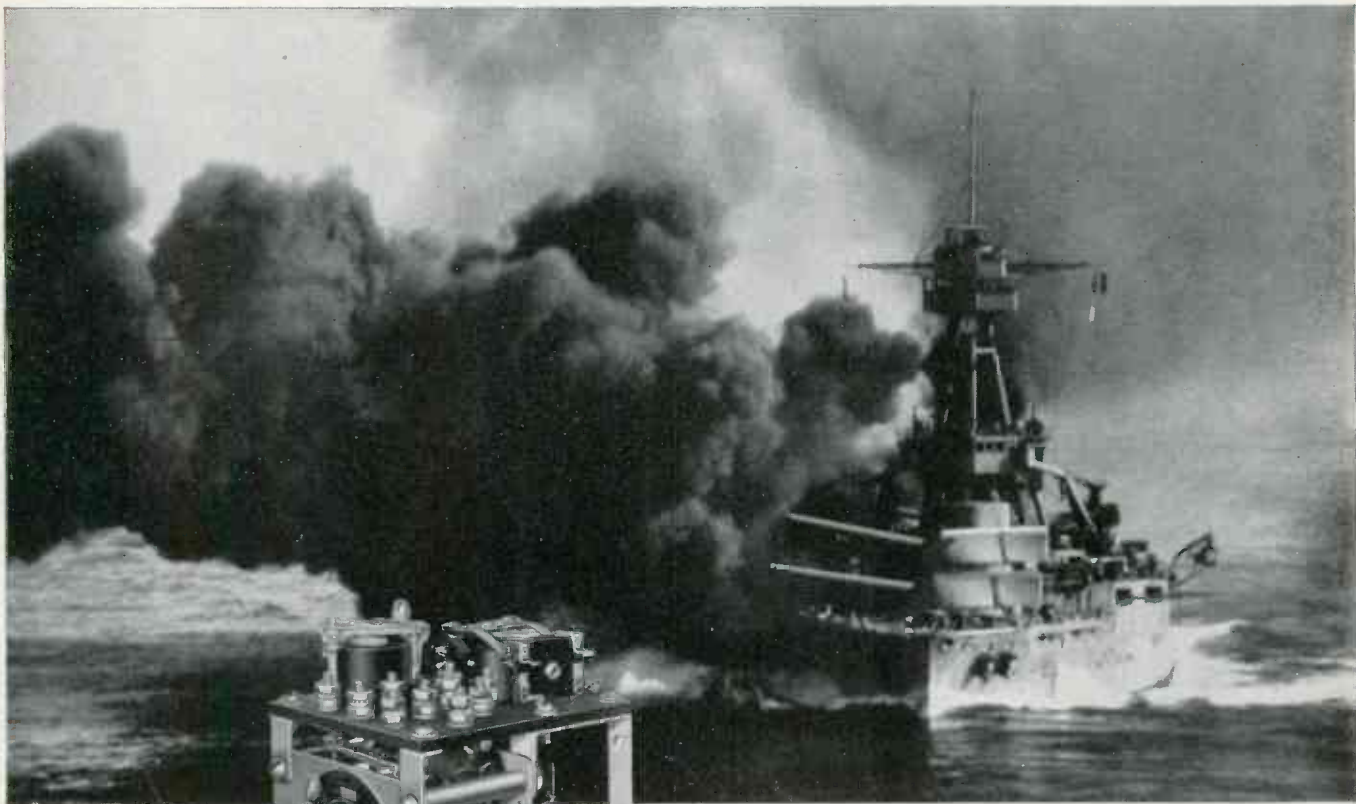

Battleship U.S.S. Texas firing main battery broadside. U.S Navy Official Photo.

IT'S IN THE NAVY NOW

We can tell you about this motor driven, time delay relay because it has been used for years in peace time activities as a time control in drying systems, heat treating ovens, illumination and many other applications.

Now it's in the Navy. The positive action, ruggedness and resistance to shock and vibration of this relay, make it ideal for alarm control, communication circuits and for the protection and timing of many kinds of equipment aboard ship. Manufacturers who are doing essential war production can often find items in the regular line of Ward Leonard Controls that will serve their needs without the delay of extensive redesigning.

WARD LEONARD

RELAYS • RESISTORS • RHEOSTATS

Electric control  *devices since 1892.*

WARD LEONARD ELECTRIC CO.

• 61 SOUTH ST., MT. VERNON, NEW YORK

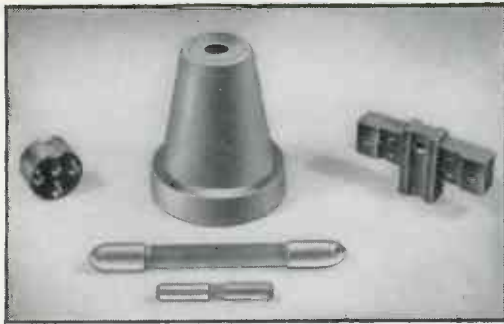

Above, left to right—Connector plug with insert and engraving; Compression-molded end seal for high voltage and high pressure; Sample of intricate EmcoMax machined part. Center—Antenna insulator with EmcoMax-to-metal seal; Molded part, EmcoMax inside metal rings.

Right—Coil support bars, of a wide variety which we make, from 24 inches long down to 6 inches. Showing the adaptability of EmcoMax to applications of this kind.

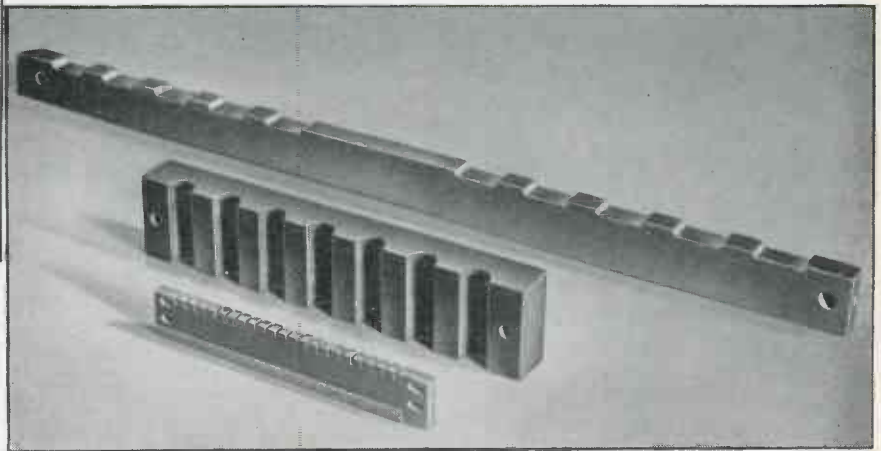

Inviting your attention to a high quality CERAMIC INSULATION

FEATURES OF EmcoMax
manufactured by
**ELECTRONIC
MECHANICS, INC.**

INSULATING QUALITIES

Highest insulating qualities are inherent in Glass Bound Mica. It is a low loss material. Extremely low loss at high frequencies. Will not dissipate high frequency energy. Will not carbonize under heat or arc; therefore cannot create a path for leakage or short.

MOISTURE RESISTANT

Absorption absolutely negligible. EmcoMax is non-porous; impervious to moisture, water, vapors, etc., thereby preventing failures otherwise due to improper insulation.

MECHANICAL STRENGTH

Nearly as strong in rupture as cast iron. Tests up to 22,000 lbs. per square inch. EmcoMax is not fragile, enabling it to withstand shock and vibration.

MACHINABILITY

EmcoMax is machinable to high precision, either in simple surfaces or intricate parts.

NON-WARPING

No strain; no impairment of electrical contacts; no change in relation to associated parts; no change in form factor.

BONDING

Perfect bond or seal, insulation to metal, permitting its use in applications where bond or seal is critical.

AVAILABILITY

EmcoMax is furnished in sheets 6" x 24" and 19" x 14", from 1/8th inch thick to 1 inch thick, or machined to your specifications, or can also be molded. Ample quantities can be furnished with a minimum time for planning.

EMCO MAX

Glass Bound Mica

Developed and manufactured under new and exclusive formulae.

Created by communications engineers
Indispensable to the war effort
A boon to many post-war industries

THE most important thing about Glass Bound Mica is the improved formula of ELECTRONIC MECHANICS, INC., which has made EmcoMax a truly better insulation. It is widely used in secret military equipment where it is doing work that no other type of insulation has been able to do.

Ultimately, this same formula of EmcoMax will be used in other fields where it will bring equally great advantages. A few of them are set forth in the column at the left.

Your product may have these same advantages if you will tell us what your problem is.

Made exclusively and machined
to specifications by

ELECTRONIC MECHANICS INC.

Specialists in High Frequency Products

70 CLIFTON BOULEVARD, CLIFTON, NEW JERSEY

A NEW *Motorola* BUILDING

DEVOTED EXCLUSIVELY TO ELECTRONIC

Research and Engineering

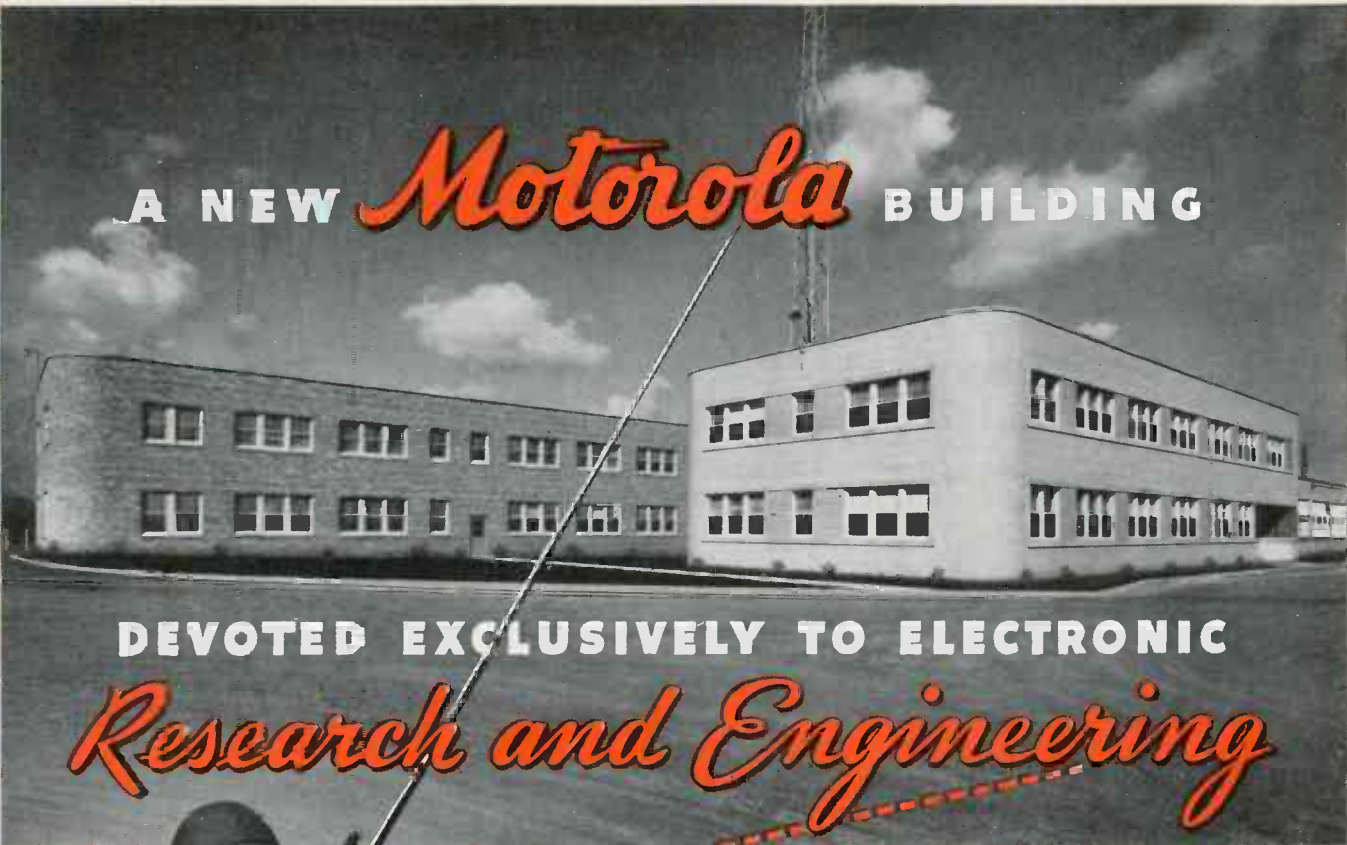

When war came, Motorola research and engineering was already at work around the clock on special assignments for our Armed Forces. Now in its new home, the Motorola staff of engineers and technicians is by specific government assignments at work on problems which embrace many important phases of electronic knowledge. This new Motorola engineering building increases many times our capacity for service of the highest order.

THE ARMY-NAVY "E"

Awarded for excellence in the production of Communications Equipment for America's Armed Forces



Photo Courtesy U. S. Army Signal Corps

**Motorola Radio Communication Systems
Designed and Engineered to Fit Special Needs**

GALVIN MFG. CORPORATION • CHICAGO



Wheezes, Wows, Squeaks, Noises,
are out because there are

NO GREMLINS

in GOULD-MOODY'S sensational
"Black Seal" GLASS BASE

Instantaneous
RECORDING BLANKS

Gremlins are those pesky little pixies who annoy pilots of the RAF and the U. S. Air Force. They're also present in many recording blanks, causing wows and rumbles, squeaks and noises. But, there are no Gremlins in "Black Seal" Glass Base Instantaneous Recording Blanks. They're the talk of the industry...giving a wide frequency range, true and beautiful reproductive qualities, and absolute freedom from noises — you hear only the performance itself! Try these Gremlin-free "Black Seal" blanks at our expense — if they don't come up to your expectations, send them back and we'll stand the entire tariff.

Old Aluminum Blanks Recoated with the
"Black Seal" Formula in 24 fast hours.

Ship and Protect your Records with the new Gould-Moody PacKARTON light-weight, corrugated container. Saves time, saves records and reduces shipping costs.*

IMMEDIATE DELIVERY! Styli and shipping cartons supplied at cost.

*REG. U.S. PAT. OFF.

THERE ARE HUMAN GREMLINS, TOO!

They're well-meaning, but kind of careless, people who buy things they don't need, who spread rumors, who throw away scrap and rags, who waste fuel, who drive their cars too fast, who aim to but don't invest in War Bonds.

Help win the war, help spread the word

— DON'T BE A GREMLIN!



the **GOULD-MOODY** *company*

RECORDING BLANK DIVISION

395 BROADWAY

NEW YORK, N. Y.

Industry steadies its "nerves"

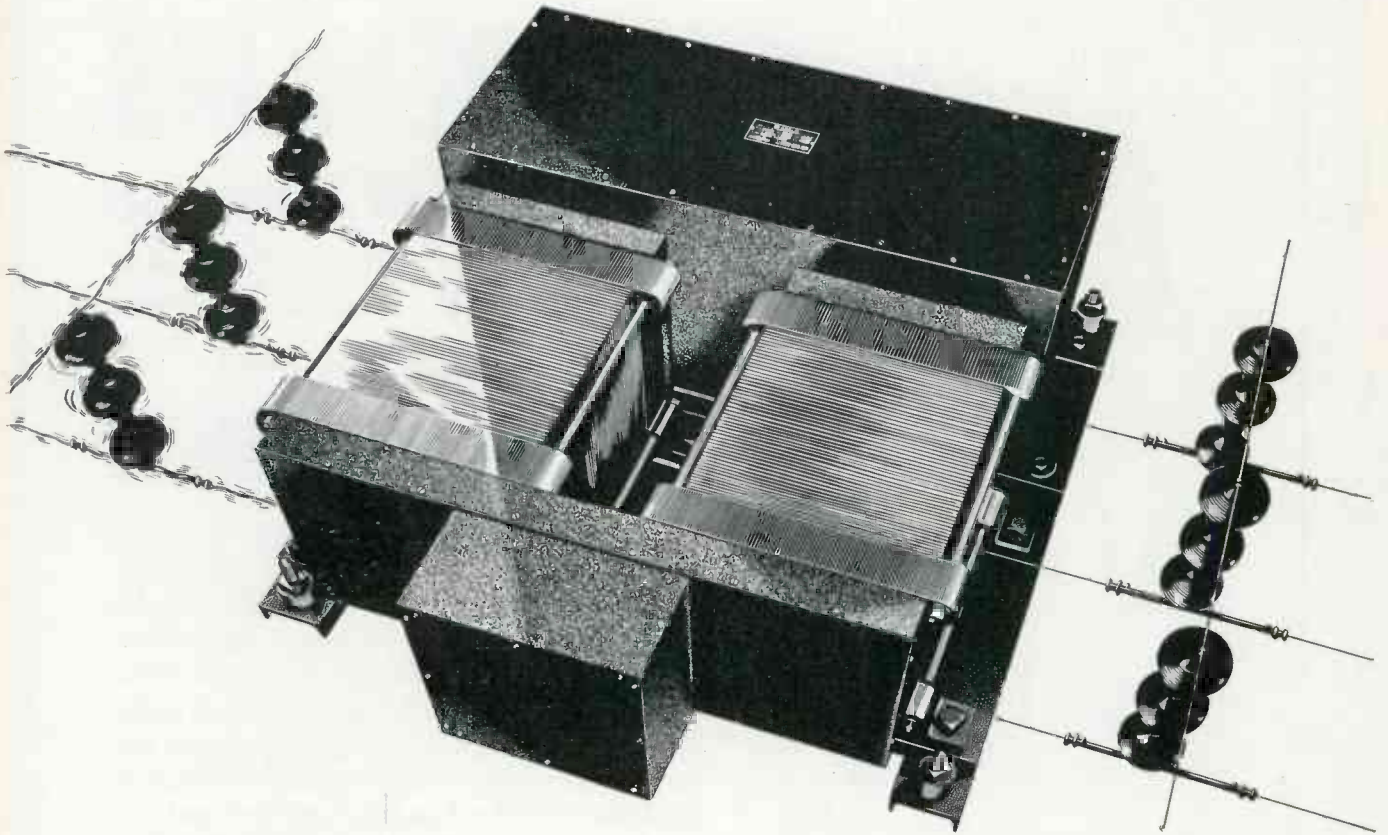

FACED with production schedules that have no precedent in history, American industry finds the fluctuating voltages of its over-loaded power lines wholly inadequate to meet the "deadly" precision demanded for total war.

Vital "nerve centers" of production lines are geared for precise performance when operated at specific line voltages. Any variation from these rated values, and there are many these days, may well mean lagging production schedules and a noticeable lack of uniformity in products.

Fluctuating line voltages are no problem in plants where Sola "CV's" have taken over. Even though the peaks and valleys of power consumption may cause a voltage variation of as much as $\pm 30\%$ —the vital "nerve centers" of their pro-

duction lines continue to operate smoothly and with unerring precision.

Day and night, without care or supervision, Sola Constant Voltage transformers maintain positive control over electrically operated instruments and machines that are indispensable to the nation's war effort. These transformers are available in standard units with capacities ranging from 15 KVA, which might be used for an entire communications system for instance, to the small 10 VA units for vacuum tubes. Special units can be built to specifications.

Note to Industrial Executives: *The problems solved by Sola "CV" transformers in other plants may have an exact counterpart in yours. Find out. Ask for bulletin 10CV-74*

Constant Voltage Transformers

Transformers for: Constant Voltage • Cold Cathode Lighting • Mercury Lamps • Series Lighting • Fluorescent Lighting • X-ray Equipment • Luminous Tube Signs • Oil Burner Ignition • Radio • Power • Controls • Signal Systems • Door Bells and Chimes • etc. **SOLA ELECTRIC CO., 2525 Clybourn Ave., Chicago, Ill.**

Listen!

TOMORROW IS COMING . .

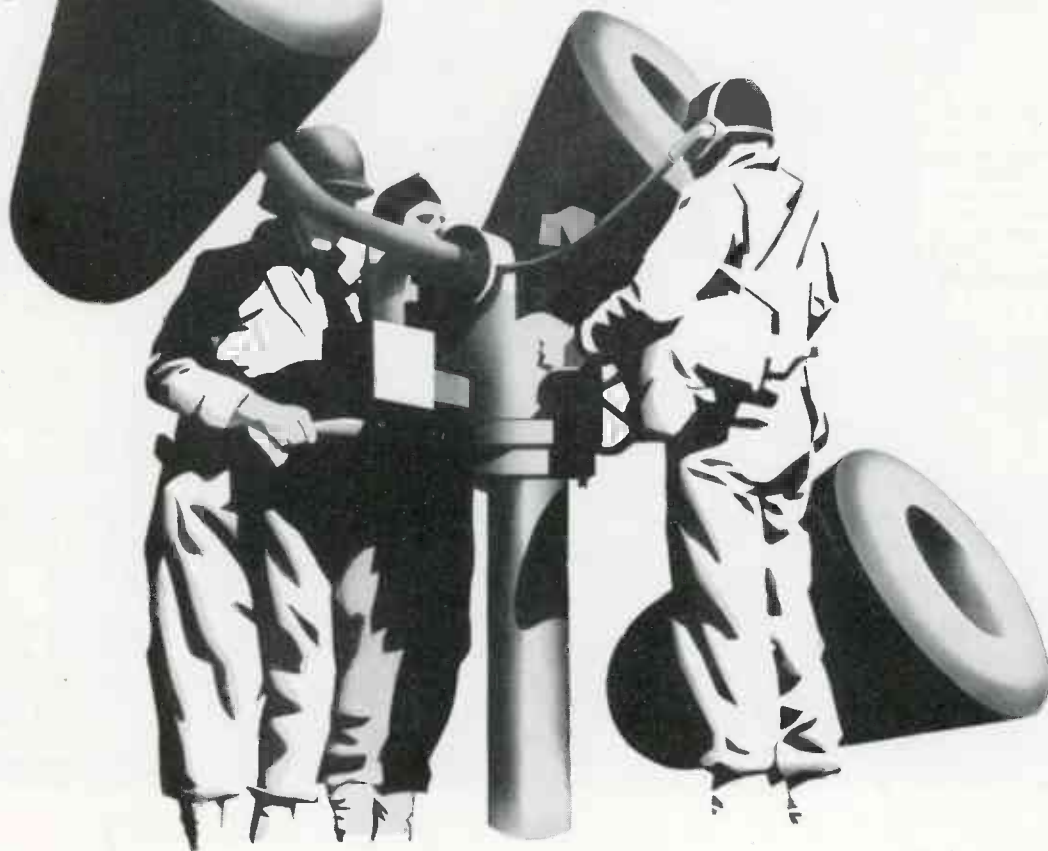

Listen! And above the clatter and crash of war you can hear the murmuring of a coming peace—whisperings from industry preparing for a new future. And there are strange new sounds—the names of new products and of new things to be accomplished. From the field of electronics come the greatest promises of all.

Tomorrow is to be the day of electronics. In industry, in transportation, in communications and in the office and the home, new efficiency, new con-

veniences and new pleasures will spring from the achievements that electronics have wrought in war.

To the companies that will produce the electronic devices of the future, TUNG-SOL has an important message. We are preparing . . . we will be ready. When, at last, this tomorrow dawns you will find at TUNG-SOL, not only a dependable source of electronic tubes for transmission, receiving and amplification, but an engineering laboratory service to help you with your plans of tomorrow.

TUNG-SOL

vibration-tested

RADIO TUBES



TUNG-SOL LAMP WORKS INC., NEWARK, N. J., Sales Offices: ATLANTA, CHICAGO, DALLAS, DENVER, DETROIT, LOS ANGELES, NEW YORK
ALSO MANUFACTURERS OF MINIATURE INCANDESCENT LAMPS, ALL-GLASS SEALED BEAM HEADLIGHT LAMPS AND CURRENT INTERRUPTORS



MICROPHONES

Yesterday . . . Today . . . Tomorrow

Prewar Microphones. In prewar microphone design, the chief development was in directional pickup. This was a stride forward in the discrimination against unwanted sounds, feedback and background noise. The most efficient directional pickup pattern was the "Super-Cardioid". It effects a 73% reduction in pickup of random noise energy. This was developed by the Shure engineering staff and is being utilized today to good advantage in many wartime applications.

War Microphones. Naturally most improvements are a military secret. It is obvious that service in battle requires—RUGGED construction never before thought possible—CONTROL of frequency response to solve

new and unique acoustic problems. Special applications are being solved for Microphones in masks and on the throat, in tanks, planes, ships and on the battlefield.

Postwar Microphones. New experience in war engineering and war production will provide tomorrow's Microphones with incredible ruggedness—special frequency responses for specific applications—controlled pickup that will permit wider use of sound amplification. When the war for world-wide freedom has been won, Shure Brothers will be ready to make its contribution to *better sound in a better world.*

Shure Brothers • 225 West Huron Street • Chicago, U. S. A.

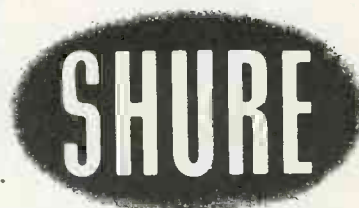

Designers and Manufacturers of Microphones and Acoustic Devices



PRECISION
POWER TUBES
FOR EVERY PURPOSE
MADE BY

UNITED

Skills in Electronics

When the war ends, there will be a phenomenal expansion in the peace-time use of electronics. Today—while the war absorbs the tube output—try to fix in your mind this unique source for tubes which you will seek tomorrow:

Its name: UNITED. Its organization: a group of eminent engineers and technicians, uniting their highly specialized skills. Its product: power tubes, unsurpassed in precision, for every electronic requirement including radio communication, physiotherapy and industrial control. Its standard: power tubes that consistently attain the highest record in every test of performance. Remember the name "United."



UNITED ELECTRONICS COMPANY

NEWARK, NEW JERSEY

It is typically American to accomplish yesterday's impossibility today!—The Raytheon research laboratory today and every day is delving into seemingly impossible Radio Electronic Tube problems and solving them in an incredible space of time.

This unending scientific research carried on at Raytheon to aid our Armed Forces during this conflict will, when we are once more on a peacetime basis, give Raytheon tubes the advantage of these newly developed electronic principles . . . Your new Raytheons will be the product of the latest scientific research.

★
**Raytheon
Manufacturing Company**

Waltham and Newton, Massachusetts

★
DEVOTED TO RESEARCH AND THE MANUFACTURE
OF TUBES AND EQUIPMENT FOR THE NEW
ERA OF ELECTRONICS

*For military reasons
the tube shown is not
a new development.*

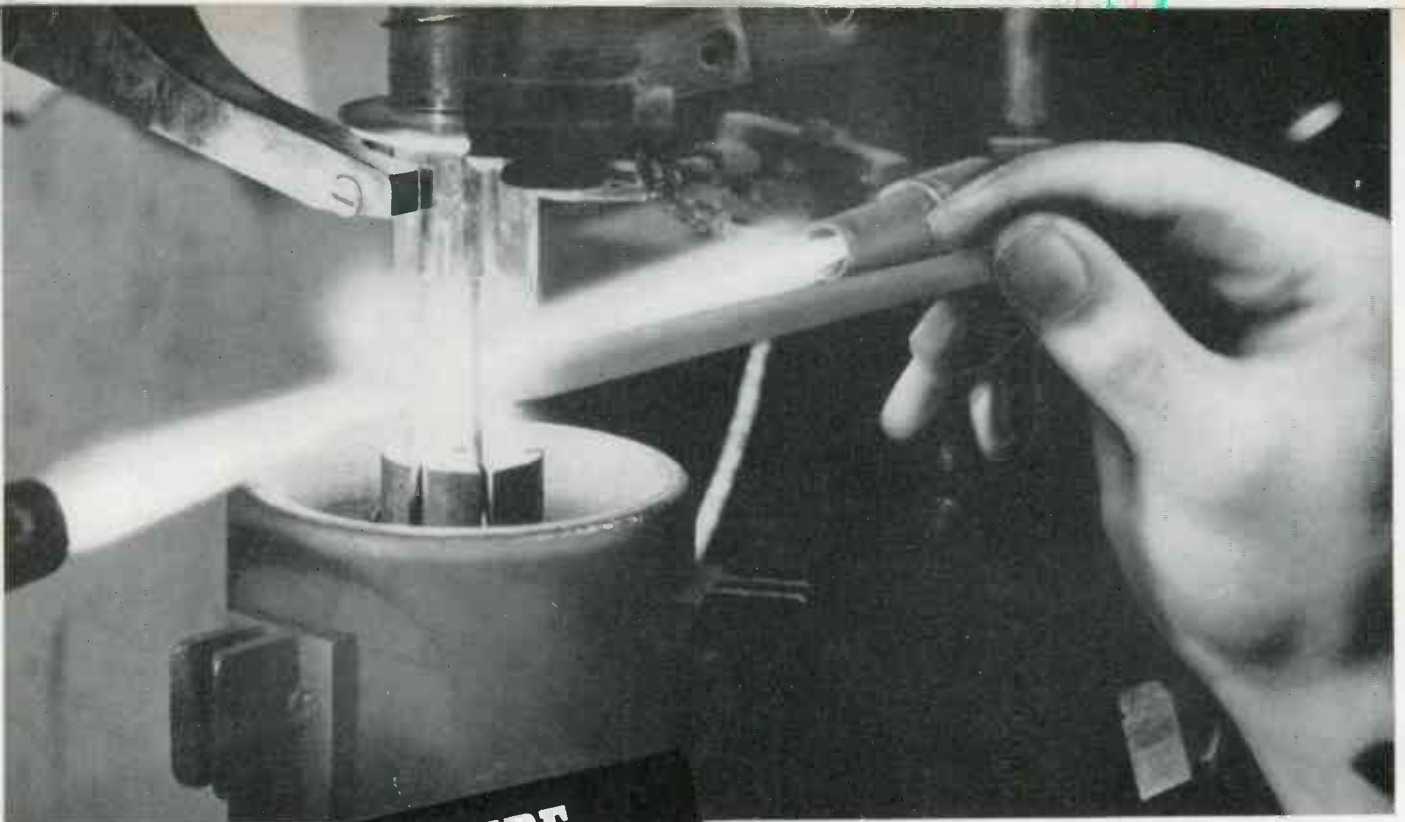

Glass tubing becomes finished filament stem with leads sealed in position on this special upright lathe.

VACUUM TUBE
Performance
IN THE MAKING...

"Trifles make perfection and perfection is no trifle"* . . . The tiniest part of every Eimac tube is a "tremendous trifle," handled with the utmost care . . . the greatest skill. In an Eimac 304T tube there are more than fifty separate parts which pass through many fabricating operations before they are ready to be assembled into the tube. Through all these steps great care is taken to hold the dimensions of each part to a very close tolerance . . . to make every welded joint perfectly solid. Such painstaking care in the fabricating of each part, plus the achievement of extremely high vacuum . . . helps provide the outstanding performance capabilities which have made Eimac tubes famous. In the toughest jobs you'll find Eimac tubes in the key sockets most every time. They are first choice among the leading engineers throughout the world.

Follow the leaders to

Eimac
TUBES

*Michelangelo (C. C. Colton)

Manufactured by

EITEL-McCULLOUGH, INC.
 SAN BRUNO, CALIFORNIA, U. S. A.

Export Agents: FRAZAR & CO., Ltd., 301 Clay Street, San Francisco, California, U. S. A.



Glass bulbs are annealed after tube is fully assembled. This action relieves stress and strain in the glass itself which may be induced during manufacture.



Deft fingers work steadily with tiny parts which are fault produced. Here plate sections are being welded together in production.

Waste is as damnable as sabotage

Electrical and mechanical design are the foundation of our military production. Small individual savings, when multiplied in mass production, add up to large savings in critical materials and labor time. Here are some examples from our organization:

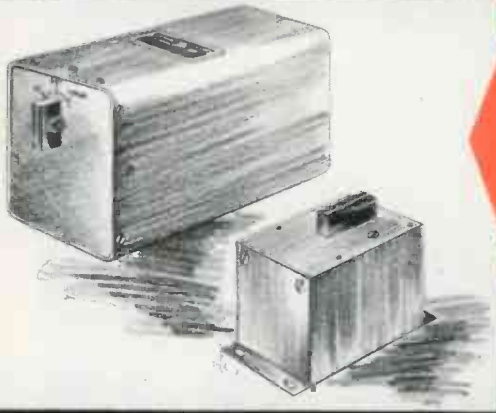

Cumulative electrical and mechanical redesign reduced the quantity of critical materials in this unit 60%, reduced total size and weight in direct proportion.

Through proper mechanical redesign, the weight and volume of this unit were halved, yet the same mounting centers were maintained for field replacements.

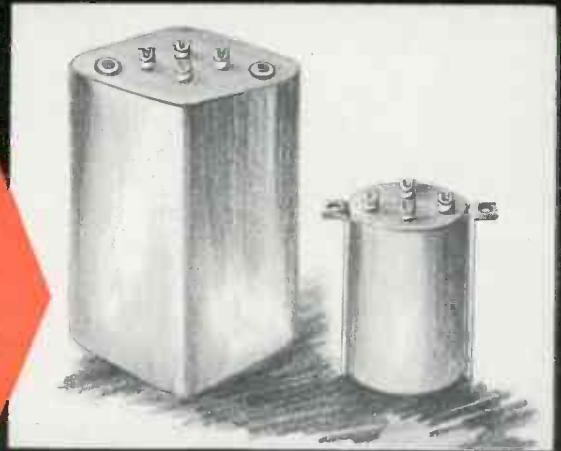

This application employed three of our Ouncer units. By combining the three in one case, we eliminated two aluminum housings, four terminals, two terminal strips, etc.

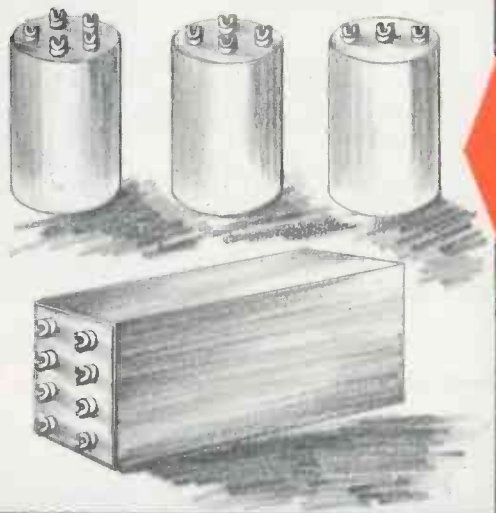

Electrical redesign reduced the amount of nickel iron alloy used in this filter by 50% . . . the mechanical redesign eliminated a dozen brass brackets and screws and cut installation time one-half hour.



UNITED TRANSFORMER CO.

150 VARICK STREET



NEW YORK, N. Y.

www.americanradiohistory.com

O. H. CALDWELL, EDITOR
M. CLEMENTS, PUBLISHER

ELECTRONIC INDUSTRIES

480 LEXINGTON AVE.
NEW YORK, N. Y.

REMEMBER, Too, Electronics at PEARL HARBOR!

The nation now knows the full facts about the terrible destruction at Pearl Harbor, Dec. 7, 1941. Few of the public, however, connect the tragic events of that day, with the fact, officially reported in all newspapers earlier, that the operator of an electronic instrument at Pearl Harbor had detected the approach of the Japanese planes 45 minutes before they struck, and while they were still 135 miles away. He so reported to his superior officer—who poo-pooed the warning.

The whole story of electronics' work that morning recounts that not one but several attempts were made by the electronic operator to spread his fateful alarm, though all in vain. For after his first rebuff—following 15 minutes of further observation (and still half-an-hour before the impending doom)—the electronic man went back to his superior, this time with the message: "But, sir, I can count fifty planes about 90 miles off, and we certainly have no such U. S. force flying there!"

This merely got him a more vigorous reprimand.

But even at that, when 15 minutes later the electronic signals had further increased in strength and nearness, the electronic operator again frantically reported, at the risk of insubordination and punishment. And again without result.

In 15 minutes more the Japs struck our flying fields, ships and shore installations. And the world now knows how battleships, cruisers and 250 planes were smashed—all needlessly by surprise.

Even after the attack, electronics was not through manifesting its marvels.

Completing their assault, it will be remembered the Jap planes flew south. Our ships followed south, hoping to intercept the Jap plane-carriers.

But the electronic operator, still on his job, soon detected the Jap planes swinging in a huge circle around to the north, where the Jap carriers actually lay. Again he reported. But our ships, fooled by the Jap ruse, were scouring the empty Pacific south of Oahu.

* * *

The heartbreaking electronic lesson of Pearl Harbor is the same sad lesson radio and electronic men have witnessed many times before, if not on so disastrous a scale. It comes back to the lack of understanding—or confidence—in new technical devices by those who do not understand radio or electronic principles. The same kind of experience has been suffered time and again in business and executive operations.

Radio and electronic men cannot rest with merely perfecting the devices of their invention. They must educate the public and the "leaders" of lay affairs, in what radio and electronics can accomplish. And they must take executive responsibility themselves.

Give technical men responsibility and executive leadership, where technical devices are vital, and there will be fewer Pearl Harbors in the future!

REMEMBER PEARL HARBOR. And remember, too, electronics at Pearl Harbor!





▲ Long lines of trucks laden with radio chassis in Kearney, N. J., plant of Western Electric Co. These sets go to U. S. Army Air Corps

▲ Dr. F. B. Jewett of Bell Labs, Dr. W. D. Coolidge of GE, Gen Barnes of U. S. Ordnance and other research heads study model of new Army tank



▲ Vista of Victory! Acres of → assembly positions and finished radio equipment in a large American factory

▲ President Roosevelt congratulates Stanley Crawford, RCA worker, on his invention of factory short cut. Behind FDR is Edwin C. Tracy, another radio speeder-upper



VOLUME



▲ U. S. tanks, radio equipped, start across the desert, in this official Signal Corps photograph. Radio is vital to tank maneuvers in warfare

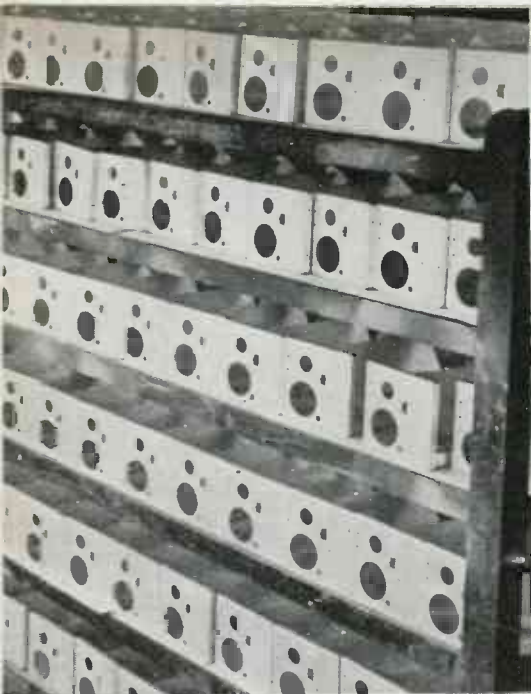

▲ American marines found this Jap radio left behind by retreating enemy at Guadalcanal, and soon got it working on American short wave broadcasts

▼ Loading box-cars with war munitions is now speeded up in this Chicago freight yard by loudspeaker system covering all loading tracks

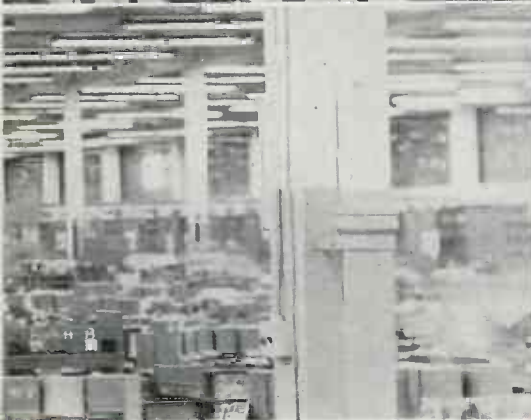

× VELOCITY = VICTORY*!

**"Equation for Victory" adapted from prize slogan in Emerson Radio employees' contest*



RAF smashes Phillips tube factory → at Eindhoven, Holland, Europe's biggest electronic center bombed. Picture sent by radio-facsimile

TANK PRODUCTION AIDED By Electronic Methods

In tank manufacturing, testing, and operation, electronic tubes and devices are finding many important applications

The bulk of the radio and electronic equipment produced for the 32,000 tanks and self-propelled artillery made in 1942 was, of course, for FM and other communications apparatus to be used under actual battle conditions.

On the home front, bigger production of better tanks and engines owes a debt to expanding utilization of various electronic methods.

In steel production

The Bessemer process of making steel is considerably faster than the open hearth or other methods. Its

Tank commander with two-button throat mike



one serious drawback has been that its control is critical. Determining the precise moment when the quantity and quality of the flame at the mouth of the converter were right for a given grade of steel, has been too exacting a job for human eyes or optical devices. Consequently the Bessemer process had fallen into partial disuse, until increasing demands for steel, largely for tanks, were felt.

Photoelectric control

In the Bessemer process, molten pig-iron is poured into the familiar pear-shaped converter. Air at about 25 pounds pressure is blown up through holes in the bottom, burning out impurities.

Determining the exact point at which to stop the "blow" has been largely guess-work. Jones and Laughlin Steel Corp., Pittsburgh, Pa., perfected a photoelectric control which is now in use by a number of producers. The Bessemer process yields 25-30 or more tons of steel in 15-20 minutes, as opposed to the 12-18 hours taken by the open hearth process to yield 125 to 250 tons.

The control consists of a photoelectric element to view the entire flame at the mouth of the converter, an amplifier, and a mechanical strip chart recorder. A group of three PJ-22 tubes comprises the viewing element, set up about 60 feet from the converter.

All-welded tanks

Newest and most important application of electronics to tank production is controlled resistance welding. Early tanks, with all-riveted construction, presented production and use problems. Cumbersome horseshoe-shaped equipment

was necessary in order to back up rivets in tank walls. On the fighting fronts, direct hits on rivets made lethal projectiles of them, inside the tanks. All-welded construction eliminates this danger, while speeding production at the same time.

Other electronic applications

Electronic tubes and devices play parts in other widely scattered fields related to tank and tank-component production and testing.

The aircraft engine manufacturers, in particular, who are producing power plants for tanks as well as aircraft, have devised many electronic methods to facilitate production. Use of X-ray radiography for bearings and other castings, electron tube induction heating to harden special parts, electronic amplification and locating of unbalance in rotating parts, and many other applications of electronics have been discussed in previous issues.

Production testing

Various types of strain gages using electronic amplification have been employed in tank testing. One such instrument makes quantitative and qualitative analyses of impacts of different types and sizes of shells against the tank body and walls.

X-ray production testing is in regular use in the examination of various kinds of welded joints and castings.

A photoelectric control to determine optimum metal temperature in connection with several forging operations is used by American Car and Foundry, Berwick, Pa. Other applications of electronic devices are being perfected by several manufacturers.



▲ **NEW VERSION** of M-4 with welded-fabricated hull eliminates danger to crew from flying rivets knocked inside under fire. Electronically controlled resistance welding plays vital part in this type construction

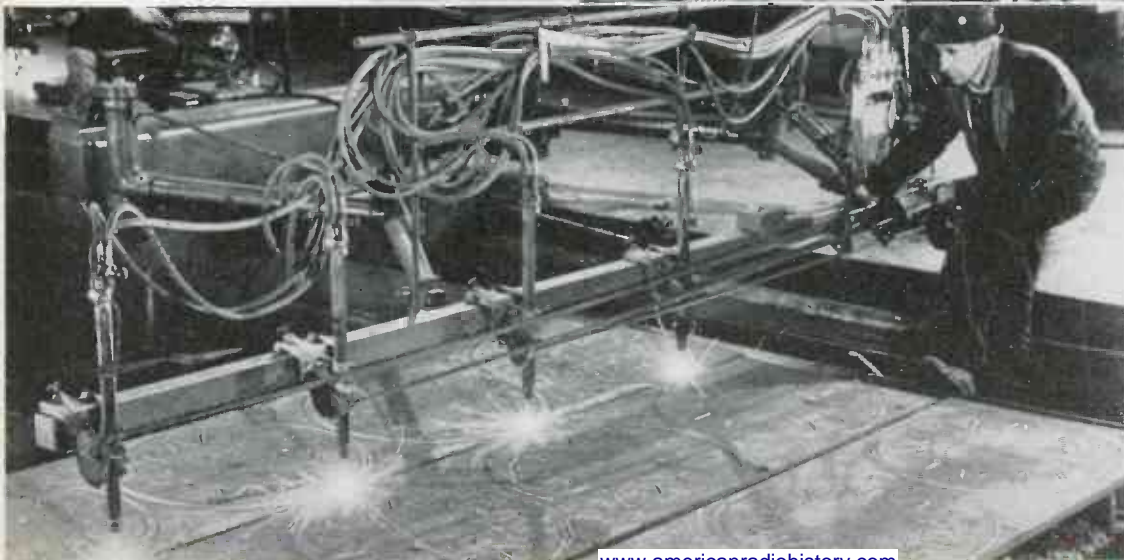

GENERAL SHERMAN tanks roll off Chrysler assembly line in Detroit, Mich., Tank Arsenal

← **FLAME-CUTTING** sprockets for Army tanks on a multiple torch Airco gas-cutting machine. This is method used to produce sprockets for new General Shermans by Lukens Steel Coatesville, Pa. Improvement has been perfected by which guide-drawing is automatically followed by traveling photoelectric cell, eliminating need for cut or formed pattern in pantograph arrangement of cutter

WHAT the NAVY

by LT-COMDR. A. B. CHAMBERLAIN

Radio Division, Bureau of Ships, U. S. Navy

Tough "specs" and tests prescribed for equipment ashore and afloat. Necessary to safeguard operations

ments originate, the steps necessary to obtain the equipment, the many considerations involved in its design, and the preparation of specifications — "military specs" — which must be rigorous, in order to insure complete reliability of equipment under the stress and strains of warfare being fought at nearly every spot on the globe, from sea-level to altitudes 40,000 or more feet above sea-level.

Or in telling you about research and development problems relating to antennas, receiver radiation, speech privacy, jamming, reduction of ship electrical noise, anti-submarine facilities, substitute materials and component parts, vacuum tubes, homing devices, direction finders for both ship and shore stations, solid dielectric semi-flexible transmission lines and fittings for very high frequency applications, hermetically sealed components. These are just a few of the many problems encountered, and do not include the many and complex ones which relate to radar and other new electronic applications.

No foolin' nowadays

The Navy needs large quantities of various types of properly designed communication, radar, underwater sound, and other related equipments. The day of "fooling around" with new designs, new gadgets and new ideas in such a way as to interfere with production of needed gear is over. Research should, and must be carried on parallel with the manufacture of existing designs. Our job, as far as the latter is concerned, is to standardize on a minimum number of required field-proven equipment designs and components—to modify, yes, but not to redesign, for redesign is the "bugaboo" of production. Let's all pull together to build, as soon as possible, the best military equipment, conservatively

designed—electrically, mechanically and physically—designed and built for 100 per cent inherent performance, reliability and long life. I say this with knowledge of the many and complex problems related to the procurement of necessary tools, materials, component parts, engineering personnel, labor and other items necessary to accomplish this mammoth task.

Routine equipment vital

There is evidence that the magic term "radar" and other new electronic devices have thrown a "smoke screen" over the importance of the much more prosaic communications type of apparatus. There is a danger in this attitude. Radar is important. It is a new tool of war that must be reckoned with, probably only second in importance to ordnance. Nevertheless, both weapons might very well be impotent without the proper supporting communications, underwater sound and direction finding facilities. Engineers working on these latter projects are just as important in the "scheme of things" as others who rush toward the newer, and to some, more attractive fields of work.

High-power low-frequency stations are still important—just as important as they were in World War I and for the same reasons. This field of activity is a lost art to younger radio engineers, but fortunately, Naval officers and engineers plus a few commercial company engineers, fully realizing its importance, have maintained interest in and continued to develop equipment for this application which is widely used today.

This example is one of many that might be cited, indicating that some of our engineers should and must concentrate on developments and improvements of the more conventional radio equipment required



This is a tough war, an "all-out" war, with no quarter given by our enemies. It is a war largely dependent upon technological advances and the proper coordination and operation of these new developments for maximum and most effective results.

Radio plays an all-important role in modern warfare. Battles have already been lost because of inadequate or poorly coordinated radio communications or because of a lack of suitable radio facilities.

I could spend days telling you, how and where equipment require-

REQUIRES OF RADIO

to successfully prosecute this war. Speaking of some of the newer and more exciting electronic applications as compared to communications, remember the simple yet practical maxim: "A chain is no stronger than its weakest link."

Navy specifications

Now just a few words regarding our Navy specifications covering components and complete equipments—you know, those "tough" Navy "specs." Our "specs" are rigorous—they have to be. A discussion with any Naval radio "old-timer" on this subject would be convincing. If not, reports received in person from communication officers recently returned from Pearl Harbor, the Coral Sea, Midway, Solomon Islands, Aleutian Islands, and other Pacific points, plus "Battle Damage Reports" regularly received, would clinch the argument.

Some of the service conditions which must be met "in the field" include: roll and pitch, extreme vibration, shock of gunfire, shell and bomb hits, salt spray, sand, humidity (ranging from low values to 95 per cent), temperature (ranging from -40 deg. to +85 deg. C.)

A typical naval radio equipment specification will now be referred to. Incidentally, this particular specification, covering portable radio receiving equipment, contains 176 pages of data and requirements which must be adhered to. It includes such items as: guarantees, warranties and certifications; sub-specifications; constructional specifications; dimensions and weights; power units, cables and auxiliary apparatus; definitions; performance specifications; tests, spare parts, drawings and instruction books; and engineering data in graphical form. Part of this specification reads as follows:

Requirements

"Acceleration and Shock: The major units of the equipment, when secured for transportation, shall be capable of withstanding the following:

- (1) A maximum acceleration of 8g (257.7 feet per second

per second) in any direction.

- (2) Not less than ten random falls to a hard deck from a height of one foot without damage to or derangement of any of the parts including the cases. Equipment shall be capable of operating immediately thereafter, in accordance with these specifications. A change in the calibration data of the RECEIVER, in excess of 0.1 per cent, shall be considered as predicating a derangement, as shall undue binding of the chassis as removed from cabinets. This requirement shall be interpreted as permitting the use of a sheet of commercial grade of soft (not sponge) rubber having a thickness not in excess of one (1) inch as a covering for the deck and as a shock absorber."

"Type Tests: One complete receiving equipment out of the total number delivered on contract shall be subjected to complete and exhaustive TYPE TESTS to determine compliance with each and every requirement of these specifications.

Should a preliminary model(s) be required on contract, TYPE TESTS will be conducted by the Navy at a Naval Laboratory or at such other point as may be required by schedule. Such tests shall not relieve the requirement for TYPE TESTING of one production equipment.

- (1) Where preliminary model tests are conducted at a Government Laboratory, sufficient tests shall be conducted at the point of manufacture to indicate that the equipment may be reasonably expected to meet the requirements of these specifications."

"Production Tests: Each complete equipment delivered on contract shall be subjected to PRODUCTIONS TESTS, as indicated in the following paragraphs, to determine specification compliance. The enumerated tests shall not be construed as preventing the Navy Inspector from conducting such other tests as may be deemed reasonably necessary to demonstrate whether or not each equipment complies with the requirements of these or other applicable specifications and is suitable for Naval use. The right is further

The new organization plan through which radio equipment matters are now handled in the Navy

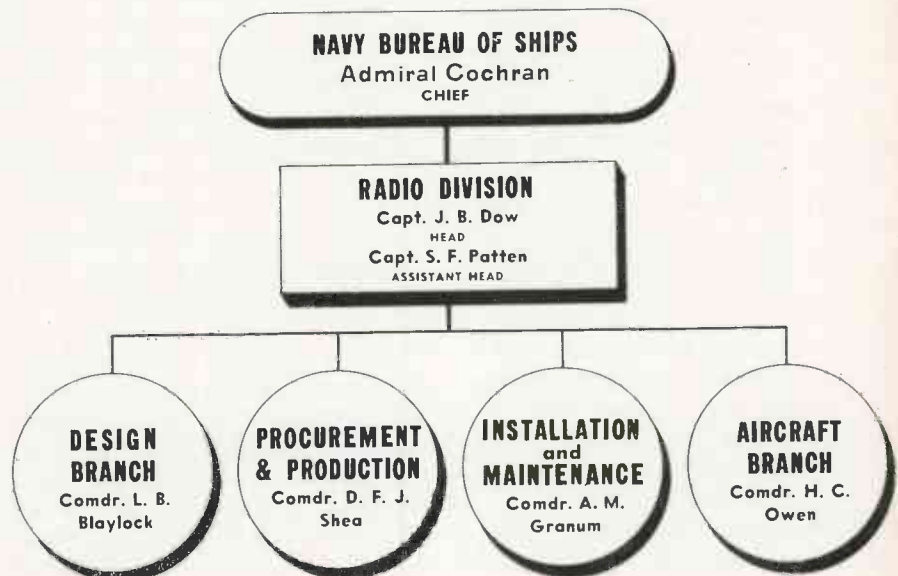

TRY THIS ON YOUR RADIO! (Or the Navy will!)

"Ten random falls to a hard deck from a height of one foot."

"Drop fifty times, a distance of six inches onto a concrete floor."

"Expose to vibration at thirty cycles per second for four hours."

"Spray with saturated salt water for eight hours."

reserved by the Bureau of Ships to authorize modification of tests, as may be necessary to suit particular designs of equipment and guard against any weakness, noted in the preliminary model(s), being reflected in production equipments."

In recently examining a "spec" covering radio equipment manufactured for one of our Allies, a striking similarity is noted, as one would expect. For instance:

"Shock: The equipment as a whole, properly mounted on its shock mounts, shall withstand dropping fifty (50) times a distance of six (6) inches on a concrete floor.

"Vibration: The equipment as a whole, properly mounted on its shock mounts, shall withstand vibration at a frequency of approximately thirty (30) cycles per second and a peak amplitude of not less than 0.10 inch for a period of 4 hours.

"Temperature: The equipment shall operate satisfactorily under any normal working conditions at any ambient temperature between -40 deg. and +60 deg. C.

(Note: Normal operation conditions shall be interpreted to mean battery voltages from 83 per cent to 133 per cent of the nominal values and an operating cycle of five (5) minutes "on" and fifteen (15) minutes "off" for the transmitters, voice or a continuous string of dots being used for modulation during the "on" period. The receivers and the interphone amplifier may be required to operate continuously.

"Dust: The equipment, properly mounted in its cases,

shall withstand for eight (8) hours immersion in a dust chamber in which the air is severely agitated and heavily laden with fine abrasive dust. After removal from the chamber the equipment shall show no condition which might prove detrimental in subsequent operation.

"Spray: The equipment, properly mounted in its cases, shall withstand a spray of saturated salt water for eight (8) hours. At the conclusion of this test the equipment shall show no conditions which might prove detrimental in subsequent operation.

"Humidity: The equipment shall withstand an ambient temperature of approximately 60 deg. C. and a relative humidity of not less than 90 per cent for twenty-four hours. After removal to a normal room atmosphere, operation with reduced performance shall be possible, and complete recovery shall take place within four (4) hours. On examination the equipment shall show no condition which might prove detrimental to subsequent operation.

"Pressure: The equipment shall operate satisfactorily under all normal conditions of battery voltage and temperature at an atmospheric pressure corresponding to an altitude of 15,000 feet."

Standardization of components

Standardization of military radio component parts necessitates simplification and compromise on the part of the various Army and Navy branches involved and on the part of radio manufacturers. Properly controlled, it becomes a means

of reducing the use of critical materials without reducing production output. In fact, production capacity is increased if the standardization plan is properly set up and executed. Furthermore it results in a minimum number of component types to be designed, developed, fabricated, inspected, stored and issued, and hence a minimum of attendant files, type numbers, drawings and specifications.

Standardization of component parts is now well under way through the joint efforts of the Army, Navy, War Committee on Radio, War Production Board, American Standards Association, Institute of Radio Engineers, Radio Manufacturers Association and the radio industry. (See "Electronic Industries," December 1942, page 33.) The armed services, including all branches of the Army and Navy, have rapidly coordinated their requirements.

Tube standards

The aims and procedure of the Navy in setting up a standardization program for vacuum tubes is an interesting example.

As the most expendable components of radio equipment, vacuum tubes must be considered both as parts of the original radio equipment and as replacement items. Naturally tubes employed for replacement must provide the same performance yielded by the equipment with the original tubes. The Vacuum Tube group develops vacuum tube test specifications, administers the Type Approval system under which Navy vacuum tubes are purchased, and, working with the tube and equipment engineers, directs the choice and standardization of new tube types.

The requirements of the Navy Department for radio equipment

(Continued on page 103)

FOR LATEST ELECTRONIC NEWS FROM WASHINGTON

Turn to page 89 (Tinted Paper)

There "Electronic Industries" Capital Correspondent, Roland C. Davies, gives a complete summary of last-minute events of electronic importance

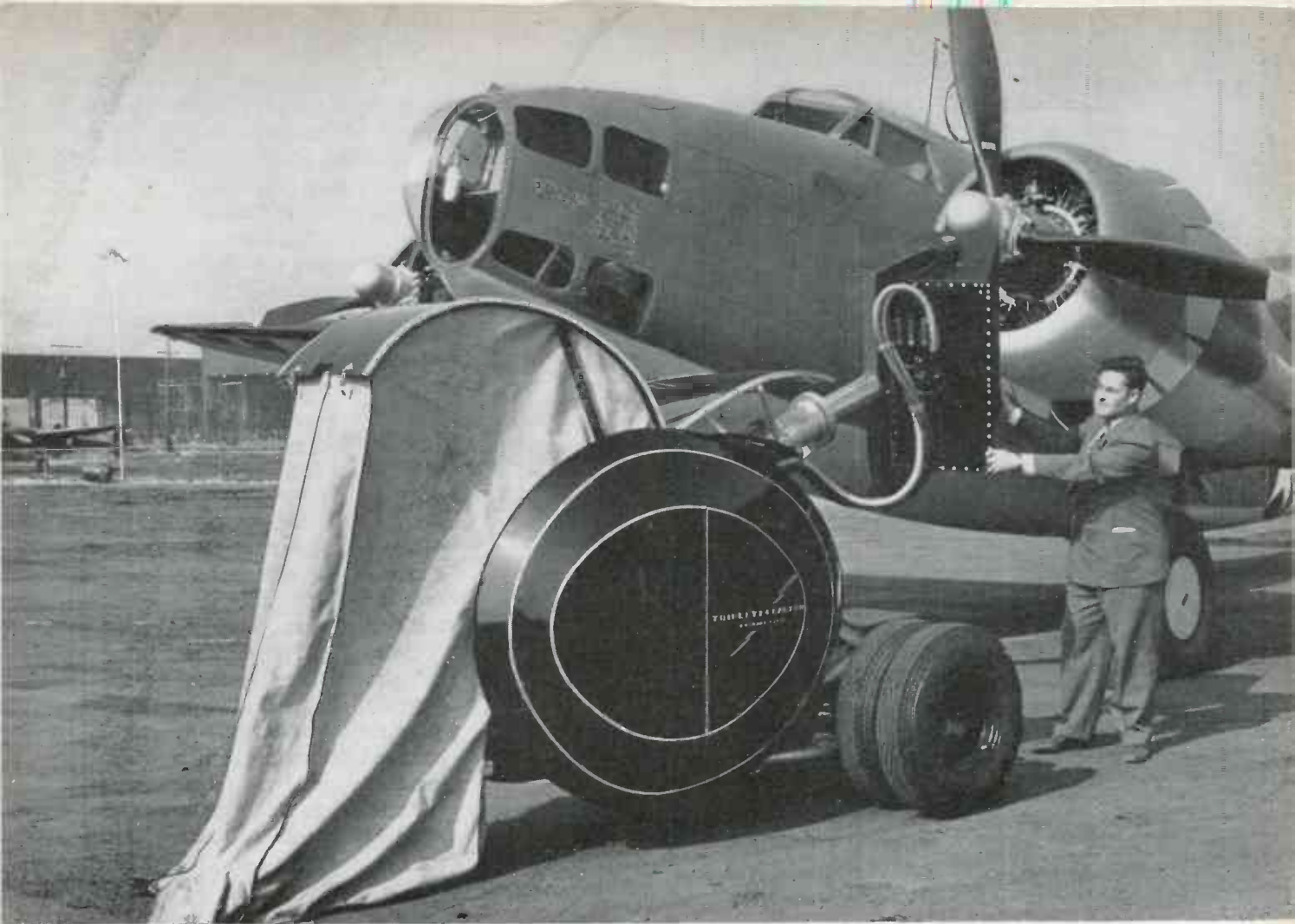

Mobile 250 kv X-ray unit with own darkroom for front-line radiographing of aircraft, demonstrated by designer Tom Triplett

★ Radio-Electronic WAR PRODUCTION

ELECTRONIC DEVICES and X-Ray Speed Aircraft Production

America produced 49,000 fighting planes in 1942. A record in quantity and quality, such production could not have been achieved without the aid of many electron tubes and electronic devices.

Automatic X-ray

One of the newest types of aircraft X-ray equipments is the Triplett & Barton electronically controlled automatic X-ray unit illustrated. Four of them used by Lockheed-Vega, Burbank, California, radiograph as many as twenty thousand castings in one twenty-four-hour day. To keep up with the accumulation of exposed films, special high-speed, automatic developing machines had to be designed.

The hood and conveyor table operate on a shuttle principle. The hood is lined with 2,000 pounds of lead to protect the operator. The electronic control allows pre-setting one, two, or more exposure techniques before the cycle of operations is started. Safety features protect the unit from circuit failures, while exposure time and line voltage are held constant by the electronic control system.

The automatic X-ray is used chiefly on small, light alloy parts. Standard X-ray equipment is used only for those castings which are too large or too heavy to be radiographed under the hood.

In addition to the obvious speed-up of production which the X-ray

Electronically timed controlled high-speed X-ray for small parts inspection



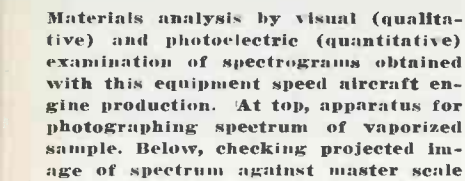
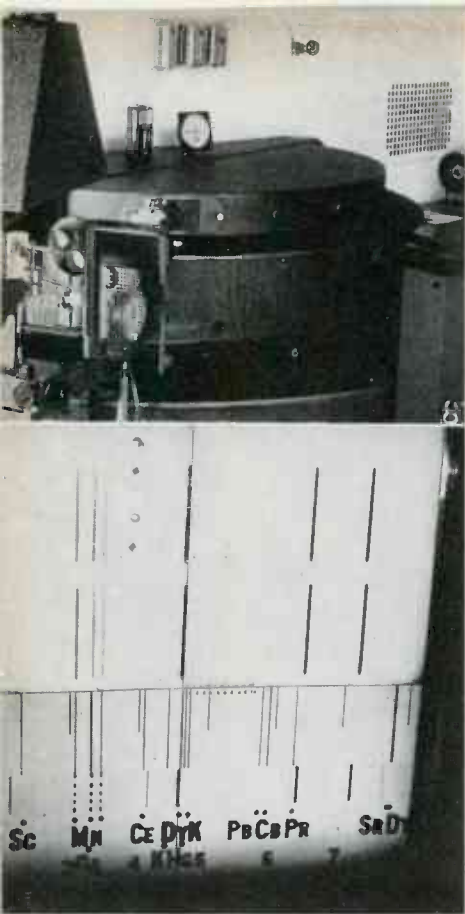

Materials analysis by visual (qualitative) and photoelectric (quantitative) examination of spectrograms obtained with this equipment speed aircraft engine production. At top, apparatus for photographing spectrum of vaporized sample. Below, checking projected image of spectrum against master scale

has effected in the aircraft industry, most aircraft engineers today specify a constantly increasing percentage of castings because of the speed and security resulting from radiographic inspection.

Dynamic strain gaging

Aircraft design for maximum strength with minimum weight is greatly aided by electronic equip-

Amplifier for cycle vibration study with strain gage as arm of potentiometer

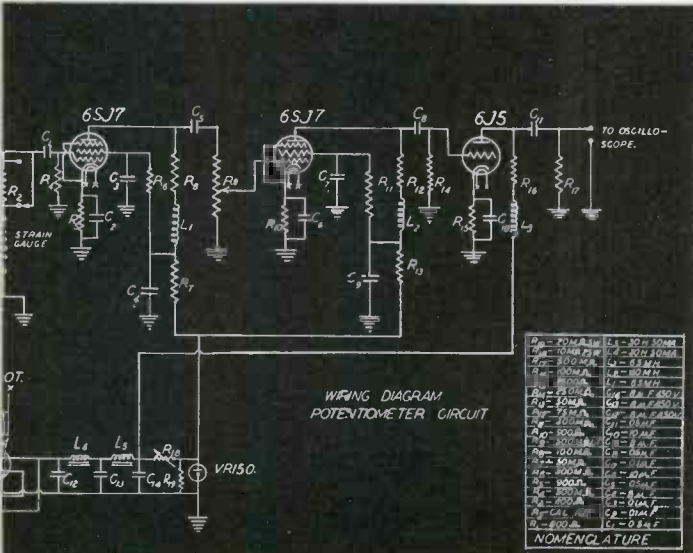

ment which measures dynamic strains by means of pickups which respond to flexing. The output is fed to high-gain amplifiers and cathode ray oscillographs which record the amplified signals.

Various types of equipment in use were discussed on December 3 at the annual meeting of the A. S. M. E., New York City, by C. O. Dohrenwend and W. R. Mehaffey of the Armour Research Foundation, Chicago, Illinois.

The pickup device may consist of a very fine alloy wire bonded by cement to a thin sheet of paper and covered with a protective layer of felt. In use, the gage is fastened securely to the part or member under test. Flexing or bending stresses the fine wire, minutely changing its length and cross-section and thereby changing its electrical resistance. Heavy lead wires carry the varying impulse to the input circuit of the amplifier. This type of gage permits measuring strains much closer to the actual surface than with the common magnetic type, in which the change in air-gap of a silicon-steel cored inductance changes the reluctance.

An amplification method that has been found satisfactory for vibration frequencies from 100 to 8000 or more cycles per second, uses the strain gage as one of the resistors of a simple potentiometer, to vary the voltage drop constituting the input. A standard ac amplifier is used because the extremely poor stability of dc amplifiers makes calibration difficult. The output of the amplifier is fed to a cathode ray tube. The time axis is obtained

either by a linear sweep of the electron beam or by mechanical movement of the photographic film used for recording.

Another type of measuring equipment, for static or low frequency strains, uses the resistance-wire strain gage as one arm of a bridge which is fed by alternating current from an auxiliary oscillator. Changes in the gage's resistance change or modulate the carrier, which is then amplified in the usual way and fed to the oscilloscope.

Electronic spectrographic analysis

Manufacturers of aircraft engines have to exercise rigid control over the raw materials they use. More and more, slow and costly chemical and physical analysis of samples has been replaced by spectrographic comparative and densitometric tests. Seventy-five to one hundred accurate quantitative and qualitative analyses, of almost any materials, can be made in one day by photographing spectra of the material as vaporized in ac or dc arc or spark-gap, then analyzing the spectra visually and photoelectrically. The light emitted by the vaporized sample is dispersed by a precision grating and the resulting spectrum is photographed on a 35-mm film strip or glass plate over a foot in length. Up to nine spectrograms may be photographed on one strip by means of a longitudinal masking device. After development of one or more film strips, each strip is placed in the analyzing apparatus. Through a narrow slit,

(Continued on page 109)

Servicing 18,000 fluorescents in Vega Aircraft, Burbank, Calif., plant, is facilitated by lamping bridge towed by monorail crane



Snowstorm Shifts Radio Beam

Bearings found in error by ten degrees during New England snowfall. Possible explanation of recent liner crashes

It is common knowledge that radio communication is an absolute necessity in our rapidly expanding field of aeronautics. And in blind flying it is the beam from radio beacons stationed at strategic points along the aerial highways, that has contributed so much to safety in flying.

Yet much is still to be learned concerning the behavior of these radio beams, points out Dr. H. T. Stetson of M.I.T. whose laboratory at Needham, Mass., has been studying radio reception effects. Reports of crashes, especially in mountainous regions, that rightly or wrongly have been attributed to beam

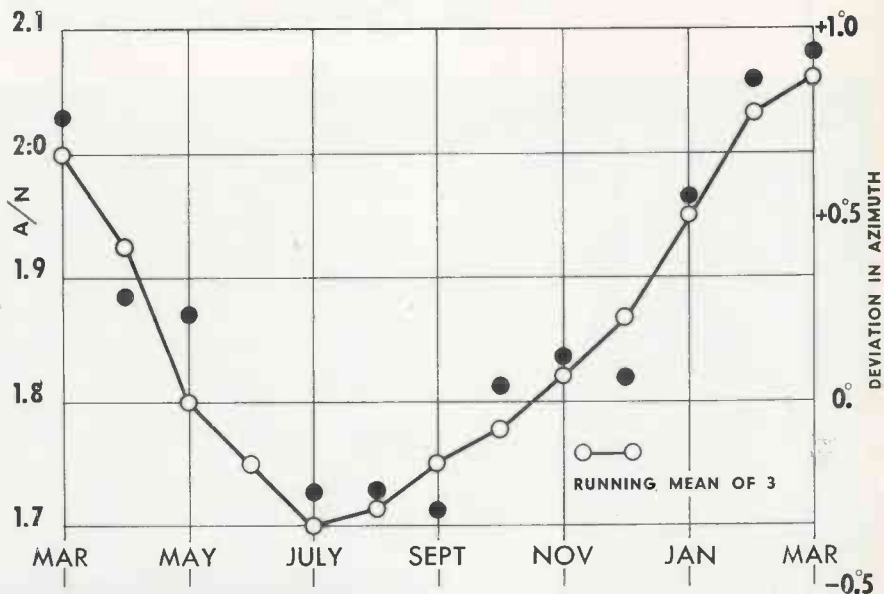

Top chart shows monthly variation of A/N of air beacon, obscured at 10-mile distance. Other charts show sharp shifts in bearings during rain and snow falls.

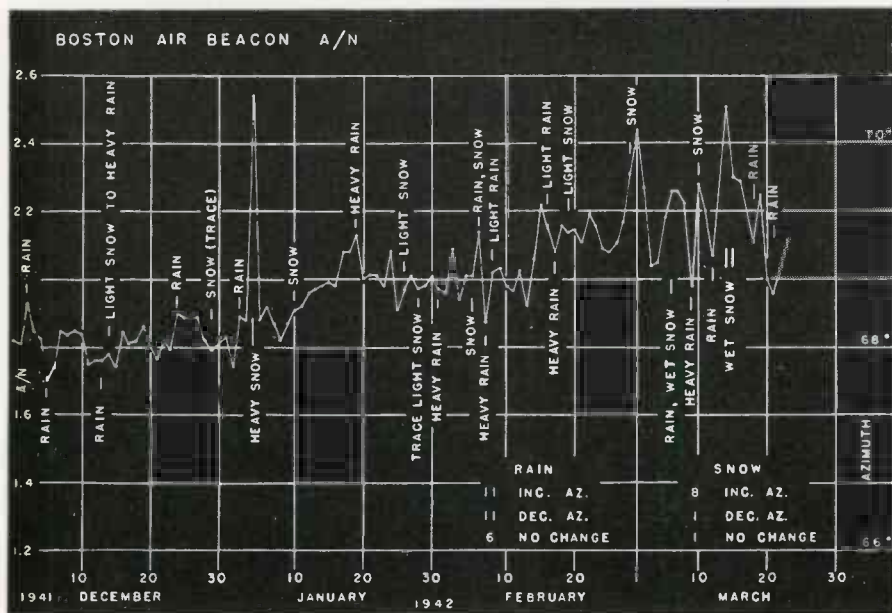

In a season's study in the vicinity of Boston, for example, an apparent easterly deviation of the bearing of a radio beacon was observed eight times out of ten with the fall of snow, while no systematic deviation could be traced to precipitation in the form of rain. At the peak of a severe snowstorm the bearing in a single instance was found to have wandered more than 10 deg. from its normal position, followed by a systematic recovery with the abatement of the storm.

distortions, need careful investigation to learn if the beam might not actually have been at fault during snowstorms along its path.

By the continuous and systematic measurement of the relative intensities of the code letters A and N broadcast from adjacent quadrants of the directive antennas from radio beacons, the pilot may judge his proximity to the on-course direction. Careful records show that the ratio of the field strengths from the adjacent quadrants varies from time to time between fixed stations over fixed distances.

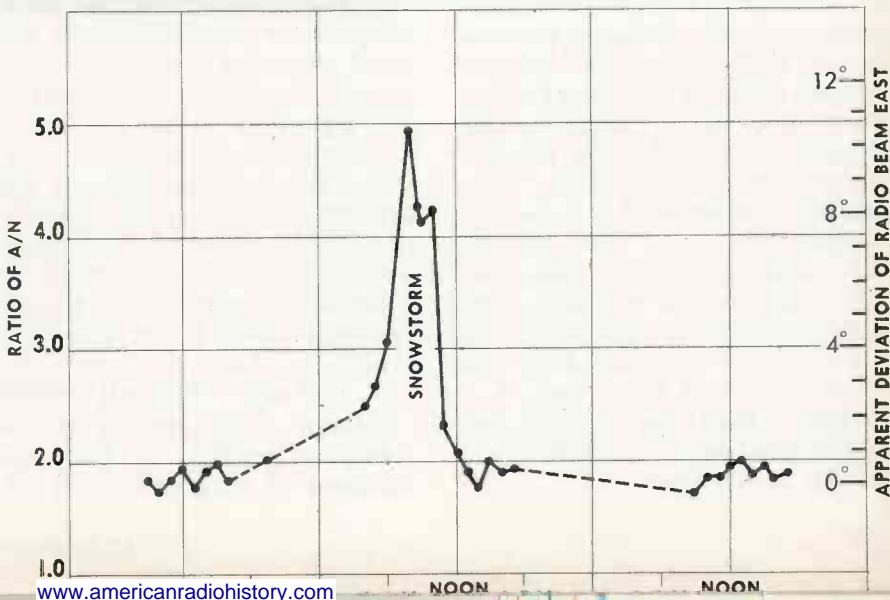

Specifications for CERAMICS

Dr. Goldsmith's task-groups, numbering 250 experts, draw up plans for simplification and standardization of insulators



DR. ALFRED N. GOLDSMITH

In developing the tremendous plans for military radio simplification and standardization under the War Committee on Radio of which S. K. Wolf, WPB, is Chairman (see last issue, page 33) many radio engineers and material experts have given their time and energies.

But undoubtedly the most extensive study and research—penetrating into a field previously little coordinated—is the work done by the large and active Subcommittee on Insulating-Material Specifications for the Military Services, headed by Dr. Alfred N. Goldsmith.

More than 300 engineers and experts are taking part in the preparation of insulating simplification and standardization plans and specification drafts—these men called from every part of the diversified insulation industries. Dr. Goldsmith and members of his Subcommittee and Drafting Groups have labored early and late, and throughout week-ends, until it is estimated that between 30,000 and 50,000 “engineer-hours” of labor are needed for the work.

Main purpose of the Subcommittee on Insulating-Material Specifications for the Military Services has been three-fold: (1) To simplify, (2) to standardize, and (3) to prepare specifications.

“Simplification” involves reducing the number of types, thus facilitating design, economizing on material inventory and also dies and tools required for manufacture, and limiting the number of types of replacement material in the field.

“Standardization” requires determination of the types which will avoid confusion and most effectively meet the largest number of uses and needs.

“Specification” involves a meeting of minds of Government and industry on clear terms and definitions, so as to avoid future confusion, disagreements and delays in procurement, manufacture, and actual applications of the products.

Types of specifications

Because of the special nature of insulation products it has been necessary to draft two widely dif-

ferent kinds of specifications: “material specifications” on the one hand; “product specifications” on the other. All of these are prepared in Federal Specification form for use by the Army and Navy.

Material specifications cover the chemical and physical characteristics of a material or of a family of related materials. These will include mechanical, thermal, electrical, and in some cases even optical or acoustical characteristics of the material. The significant characteristics which are selected are based on the “end use” of the final product in which the material is employed. These characteristics are determined by prescribed test methods. Adjacent ranges of values of such characteristics are given appropriate letter or number designations. There are thus formed “bins” or “pigeon holes,” each appropriately labeled, and into which each of the materials may fall. The materials can then be designated by the selected labels on the corresponding bins, being thus specified for characteristics which the materials should have. This is a simple and convenient way of classifying materials according to the needs of the resulting product. The classification of materials is also worked out in such fashion wherever possible as to permit the substitution of a new and abundant material for one which is becoming scarce. Appropriate test methods are listed in the specifications with other necessary provisions.

Product specifications

Product specifications on the other hand involve primarily the description of appropriate shapes or forms, their dimensions and tolerances. Wherever possible the number of such forms of a given product (for example, insulators) is reduced to a minimum, thus simplifying the procurement, design and manufacturing processes. The changeover from an earlier practice

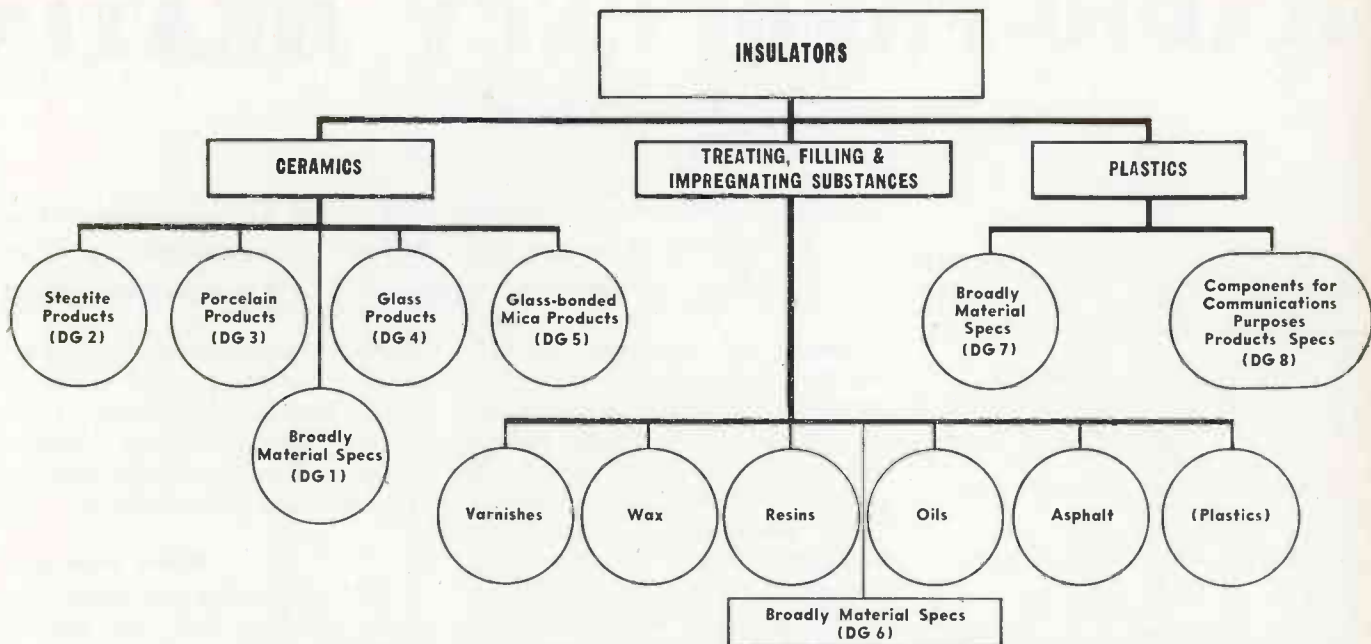

Breakdown of various types of insulations employed in radio-electronic fields. This classification was used as basis for assignment of the Drafting Groups (DG) who drew up specifications

to the new forms as specified, may be a somewhat gradual process so as not to disturb production. There are also included in product specifications matters of dimensional stability such as the permissible amount of warping. Maximum allowable defects in the products (such as, chips, blisters, and the like) are also specified. And the criteria of good engineering design are set forth in the product specifications in order that the quality of the product may be systematically improved with time. The designs set forth in the product specifications are selected in such a way as to permit, wherever possible, substitution of the product made out of one material, for the product made out of another material so as to minimize the effect of shortages in any given material.

Drafting groups

As shown by the accompanying chart, the work of drafting the various sets of specifications is being performed by eight Drafting Groups whose work has been assigned as follows:

- Drafting Group 1—Material Specifications of Ceramics for Radio Insulators.
- Drafting Group 2—Product Specifications of Steatite Radio Insulators.
- Drafting Group 3—Product Spec-

ifications of Porcelain Radio Insulators.

Drafting Group 4—Product Specifications of Glass Radio Insulators.

Drafting Group 5—Product Specifications of Glass-Bonded-Mica Radio Insulators.

Drafting Group 6—Material Specifications of Treating, Filling, and Impregnating Insulating Materials.

Drafting Group 7—Material Specifications for Plastics.

Drafting Group 8—Product Specifications for Plastics Communications Components.

H. R. Wilsey, secretary of the insulation subcommittee, is a member of the ASA staff, 29 West 39th St., New York.

The first five groups relate to ceramic materials and devices. Sev-

eral of these specifications are now drafted and ready for referring to interested industry groups, or already have been so referred, and will soon be finally adopted.

Points covered

In general the specifications on materials relate to grades and types, materials, general and detail requirements, loss factor and dielectric constants, methods of inspection and tests, quality of test specimens, loss-factor tests, dielectric strength tests, flexural strength tests, resistance to thermal change tests, porosity, packing and marking, substitutions, etc.

Specifications on products, such as steatite insulators cover: grade, type designation, types, material and workmanship, general requirements, methods of inspection and test, packaging, packing and marking, and design criteria.

Supplement with this issue—Large Folded Chart

THE FUNDAMENTALS OF SOUND

Compiled by "Electronic Industries" in cooperation with the Bell Telephone Laboratories

Showing characteristic volume levels of war and peace. The decibel levels of modern big guns and of the great super sirens used for air-raid alarms in American cities, as well as familiar sounds of everyday life. Also frequency ranges of musical instruments, human voices, etc. Basic sound constants and sound formulas.

RADIO-FREQUENCY HEATING

by JOHN P. TAYLOR*

RCA Mfg. Co., Camden, N. J.

Increased economies and speed of tube-generated induction currents. Solves production of airplane propellers made of compregnated wood

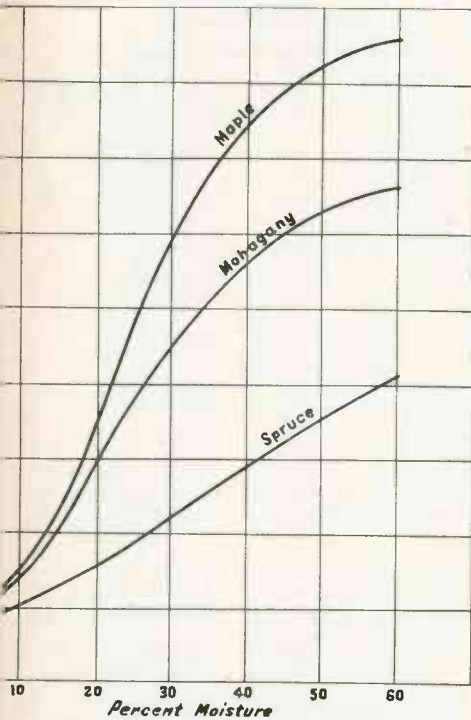

Variation of power factor with per cent moisture for three woods. Curves should be used only as a first approximation

Radio-frequency power has been used to overcome what seemed an insurmountable problem in the production of airplane propellers made of compregnated wood. Radio frequency is being used to expand the production of laminated and box spars, truss-type rib constructions, bomber floors, bomb bay doors and other aircraft parts. It is being tested for use in making various molded plywood forms such as wing

Variation of power factor with frequency. At higher frequencies these curves tend to flatten out

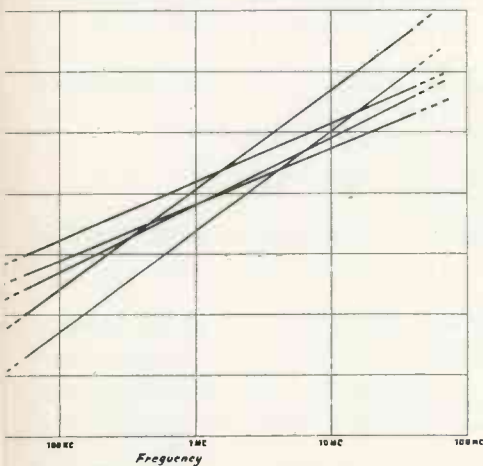

elements and fuselages. Experimentally it is being used for seasoning wood, drying aircraft-quality plywood and curing various types of impregnating resins. In all of these applications the desired effect is obtained as a result of the heating developed in the wood by the use of radio-frequency power.

Obviously these applications are important—and this lends importance to the questions which naturally arise: How is radio frequency power applied? What makes the wood heat? Why is radio frequency current used? What ad-

vantages does the process offer? What limitations does it have? What kind of equipment is required? How much does it cost to operate? How do results compare with those of other methods?

Basic principle

There is nothing very mysterious about the fact that wood can be heated by radio frequency. Almost any material we know of will heat up if an electric current of sufficient intensity is forced through it.

In the case of the poorer conductors (sometimes called insulators)

*From paper presented before Philadelphia Section, IRE, Dec. 3, 1942.

Variation with frequency of the reactance X_c , the equivalent resistance R_p and the voltage E across the load for a typical radio-frequency heating set up. Note that voltage E varies inversely as the frequency; hence, higher frequencies mean less danger of voltage flashover

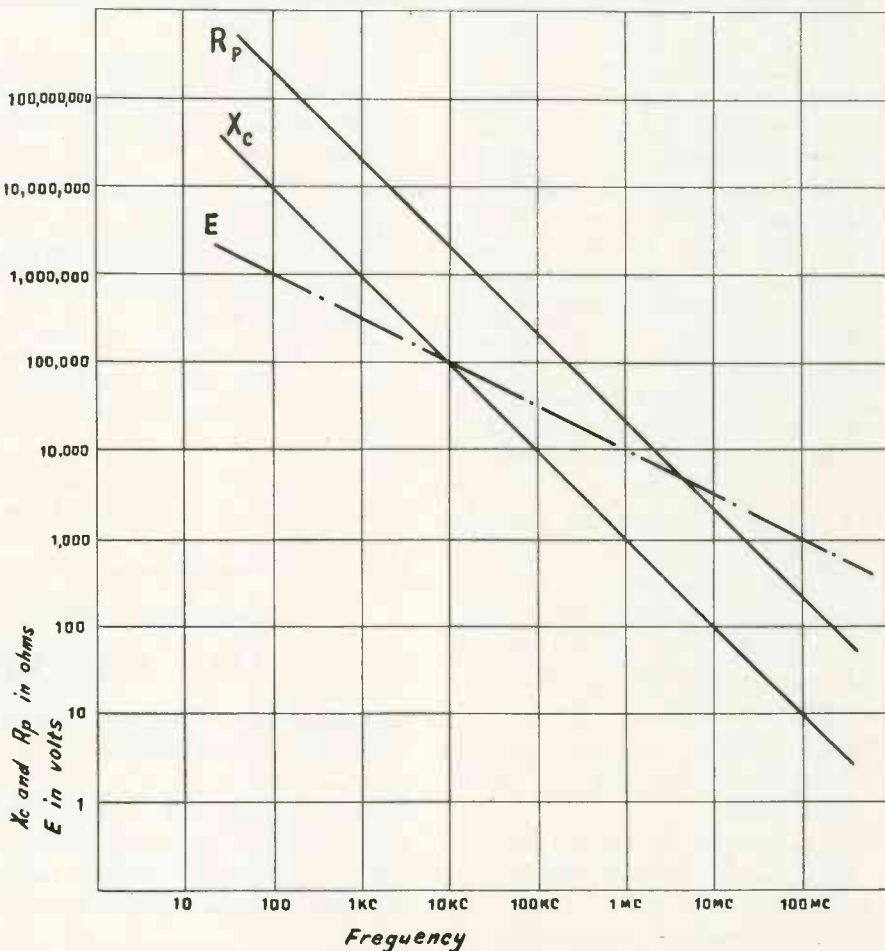

OF AIRCRAFT PARTS

such as wood, the resistance to the passage of direct or low frequency current is very high. The force (i.e. voltage) which would be required to cause an appreciable 60-cycle current to pass through these poor conductors would be out of practical reach (of the order of millions of volts). However, as the frequency of the current is increased, the equivalent resistance of these materials drops almost inversely. At frequencies in the range of what we normally call radio frequencies it becomes low enough that it is practical to force through these poor conductors enough current to heat them as we desire.

Orbit electrons

Physicists picture the heating which occurs as being due to "molecular friction" caused by the passage of current through the materials. They visualize this current not as a stream of electrons each of which flows all the way across the material, but rather as the net effect of the motion of all the electrons. Normally these electrons have random orbits. When a voltage is impressed across a section those electrons which are not too tightly bound change their paths somewhat so as to produce an overall effect of a charge moving from one side to the other. This displace-

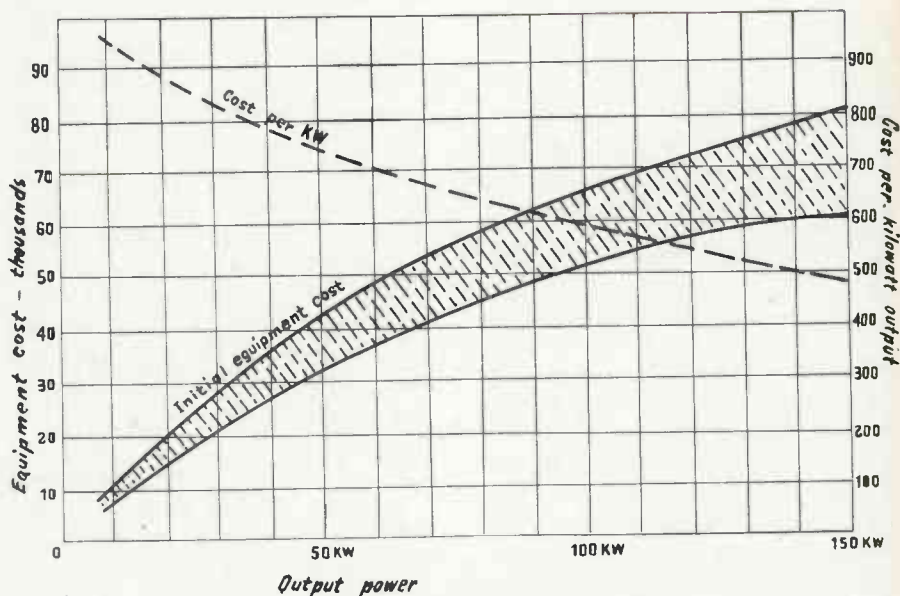

Initial cost of radio-frequency equipment and cost per kw based on a number of installations made by different manufacturers

ment of the paths of the electrons represents work done and this work appears as heat.

The difference between good conductors and poor conductors is represented by the degree of freedom of the so-called "orbit electrons." There is no fundamental difference in the heating effect. In either case it is due purely to the "conduction loss" which occurs due to actual passage of current through the material.

Where the dimensions of the "package" of wood to be heated are

known, it is relatively easy to calculate the voltage which will be required to obtain a certain heating effect. Electrically the metal electrodes between which the wood is placed form a condenser. If these electrodes were separated by air they would form a so-called "perfect condenser." In this case the voltage and current are 90 degrees out of phase and the average power dissipated in the condenser is zero.

The voltage required for a given power input (i.e. a given heating effect) is inversely proportional to

Power required to heat a wood having a value of $pc = .25$, to a given temperature in a given time

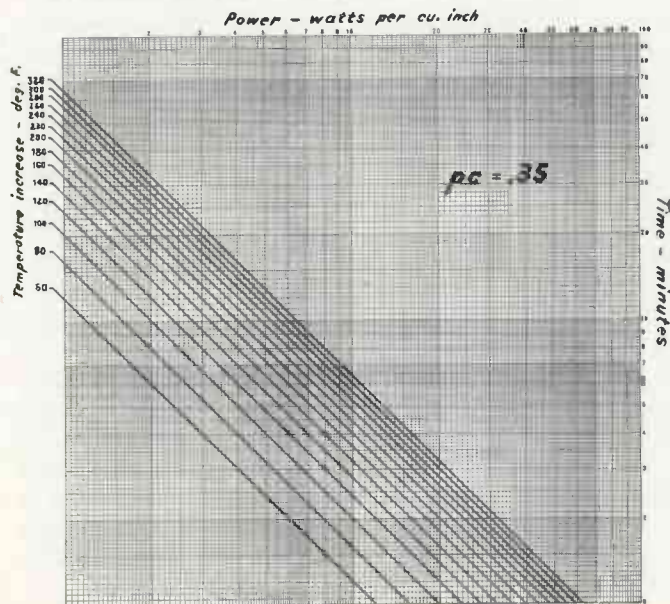

Same as chart at left, except for wood or other material having a value of $pc = .25$

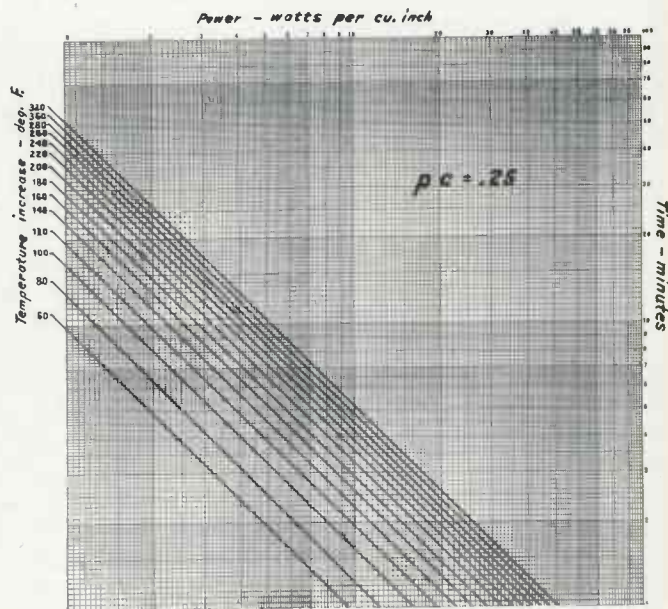

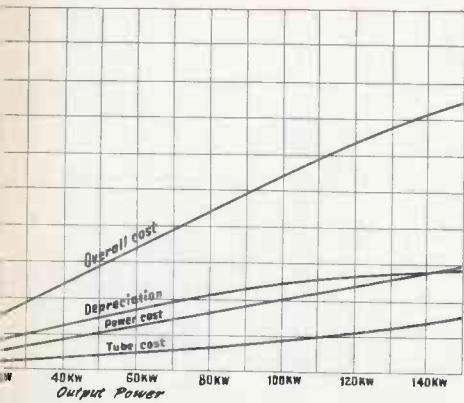

Approximate tube, power and overall operating cost versus power delivered to the load

the square root of the frequency. This means that, generally speaking, the higher the frequency, the better, although a practical limitation is encountered due to the fact that the efficiencies of some types of tubes fall off at the higher frequencies. There may also be difficulties due to current distribution at the higher frequencies. The actual maximum voltage that can be tolerated will depend chiefly on the thickness of the load. For very thin materials not more than a few hundred volts can be used before arc-over occurs. In thicker sections as much as 15,000 volts can be used.

Temperature distribution curves for 1", 2" thickness of spruce heated 5 watts/cu. in. A for wood directly against cold plates; B against thin metal electrodes; C for thin tinny material between wood & press plattens

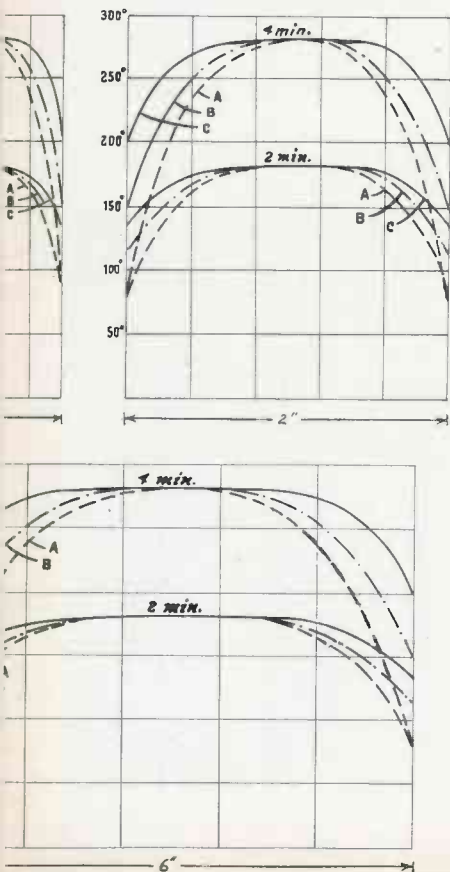

Generally, voltages much above 15,000 cannot be used, no matter what the thickness, due to corona effects which become evident at higher voltages and which only partially depend on electrical spacing.

Averaging these various factors together, it has been found that the range of 1 megacycle to 10 megacycles presents the best immediate possibilities. Some very thin sections, however, will require higher frequencies—and looking to the future (when a wider choice of high-frequency tubes will presumably be available) it seems very probable that a higher range of frequencies will come into use.

Time of heating

In order to give an idea of the powers required in typical instances, two sets of curves have been made up showing the relation of power concentration to time interval for several different temperature increments. These curves are based on values of $pc = .25$ and $pc = .35$. Most woods give values which lie between these two curves. Where accurate data is available the curves may be used for other values of pc simply by noting that the time will be increased or decreased in proportion to the value of pc .

It should be noted that the power requirements as indicated by these charts are the power which must be used up in the wood itself. In other words, if there is any loss of power, it will have to be supplied in addition to the above. Fortunately the losses (through conduction to the press and radiation to the surrounding air) are small if the cycle is relatively short. For purposes of calculating the power to be supplied to the press, they can be assumed to be of the order of 10 to 20 per cent. This is in marked contrast to most hot-plate presses where a large part of the power furnished the press is used to heat the mass of metal and a very considerable proportion is dissipated in heating the surrounding air. The lack of heat about a radio-frequency press is in marked contrast to conditions in the vicinity of a hot-plate press in operation.

The required power as estimated from the above is a good indication of the radio-frequency power to be furnished by the generator.

In cases where the generator is rated in output—that is, in terms of the radio-frequency power it actually puts out—the indication is direct. Where the generator is rated in input power—that is, power it takes from the line—an efficiency factor of 50 per cent should be used. In other words, a generator with an input rating of 10 kw will actually put out about 5 kw of radio-frequency power. The same factor

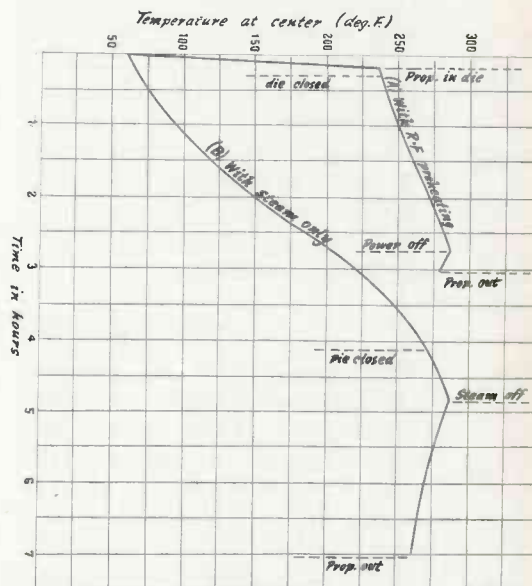

Temperature versus time curves for production of compreg propellers (A) using radio frequency pre-heating and (B) with steam only

should be used in calculating power consumption—viz., a press that requires 15 kw of radio-frequency power for a certain heating process will, with associated equipment, draw about 30 kw from the line.

Operating costs

The cost of radio-frequency power per kilowatt is not uniform but rather decreases gradually as the power of the installation increases. This is illustrated by the curve drawn up from such information as is available on installations made to date. Unfortunately, varying applications and engineering costs were necessarily involved in these. Also, there was some difference in cost of equipments of different manufacture. For this reason all available information was plotted and a broad curve drawn so as to include all points. The result at least gives a quick indication of what installations to date have cost. The dotted line on this graph

(Continued on page 111)

PARTS for CIVILIAN SETS

Simplified replacements list referred by WPB to industry committee before issuing Limitation Order

Two official bodies in Washington are concerned with plans to reduce the number of civilian radio-replacement and repair parts manufactured during coming months and for the duration of the war. Not only must the number of such units made be severely limited, but the number of separate items will have to be cut, leaving a minimum which will have to serve for as many different kinds of civilian repairs as possible.

The Radio Division of the War Production Board has the problem of reducing the production of radio parts for civilian use. Under Director Ray C. Ellis of WPB, Frank A. McIntosh is in charge of civilian-radio matters and, working with a radio industry committee, has drawn up a proposed list of radio parts the manufacture of which will be permitted by eventual WPB Limitation Order.

To safeguard prices

To avoid price rises when such radio parts become scarce, Leon Henderson's OPA office is next concerned, OPA has therefore initiated a program to have clear-cut specifications of these radio parts drawn up by a neutral group of industry representatives, operating under the auspices of the American Standards Association.

Both WPB and OPA are therefore working closely with the new ASA War Committee on Replacement Parts for Civilian Radio, whose members have been drawn not from individual corporations, but from bodies (directly or indirectly representing groups concerned), such as industry associations, license laboratories, and publishers.

Enough items

This committee's responsibility is also to represent the radio industry's point of view in seeing that enough types of units and the most suitable units are made available, despite the cutting-down process,

so that the widest variety of home receivers can be repaired with the limited replacement parts that will be manufactured.

It is expected that these standards will serve as basis for a Limitation Order by WPB and for allotment of materials for manufacture by the War Production Board. At the same time the standards will give the Office of Price Administration a definite foundation for an order fixing the prices of these standard parts of standard quality.

Final standards

The final radio standards are expected to contain performance, dimensional and construction requirements for a limited but fully adequate line of replacement parts designed to service practically all of the modern home receivers in use

today. On WPB recommendation, no provision will be made for parts to repair automobile radios or battery portables. Radio tubes are not included in the project.

Simplifying

In the design of these standard parts, every effort will be made to provide units that will be mechanically interchangeable with present parts, with a minimum of difficulty. In addition, non-critical or less critical materials, and less of these materials, will be used wherever possible in the wartime parts as compared to their peacetime prototypes.

Through simplification of the number of varied ranges now in use and the use of multi-purpose units where practicable, the actual num-

(Continued on page 108)

War Committee on Replacement Parts for Civilian Radio



Front row, left to right—Arthur E. Rhine, RSA, New York; Earl A. Graham, Head of Consumer Durable Goods Section, Standards Division OPA, Washington; Dr. Orestes H. Caldwell, editor "Electronic Industries," chairman; Frank A. McIntosh, chief of Civilian Radio, Radio & Radar Division, War Production Board, Washington; Samuel Weisbroth, Radio Division, WPB, Washington. Second row—M. M. Brandon, Underwriters Laboratories, New York; P. R. Butler, General Electric Radio, Bridgeport, Conn.; John Borst, chief engineer, John Rider Publisher, Inc., New York; Dr. P. B. Agnew, secretary, American Standards Assn. Top row—J. W. McNair, ASA; S. L. Chertok, ASA, secretary of the Civilian Radio Committee; Gerrard Mountjoy, RCA License Laboratories, New York. Other Members of committee, not present when picture was made, are: G. F. Du Val, RSA, Brooklyn; J. T. Filgate, Hazeltine Service Corporation, New York; M. J. Schinke, Stewart-Warner Corp., Chicago; K. S. Geiges, Simplification Branch, WPB



Active heads of RMA engineering dept. Center, Dr. W. R. G. Baker, Director
Left, Virgil Graham, Associate Director. Right, L. C. F. Horle, Consulting Engineer

RMA ENGINEERING DEPT. Concentrates on WAR

by Dr. W. R. G. BAKER

Vice-President, General Electric Co.
Director RMA Engineering Dept.

How Materiel Bureau, from study of substitutes, was converted to design and coordination of military radio

Major changes have occurred in the work and objectives of the Engineering Department of RMA in the past year. The radio industry has completely converted its facilities to support of the war effort.

Last year the Materiel Bureau had been established in hope of providing for the continued production of some civilian radio equipment without interference with the growing war effort. Before the end of 1941 it became evident that nothing short of complete conversion of the industry to the support of war effort could possibly meet the needs for military equipment. The formal work of the Materiel Bureau was first curtailed and then finally stopped. Not, however, before much progress had been made in the development and application of substitutes and alternates to critical and strategic material in the production of radio equipment. And it is through the work of the Materiel Bureau that some expedients to avoid production bottleneck in military equipment are based.

With the increasing realization of the role which we in America were expected to play in the prosecution of the war has come not only the conversion of the radio industry, but the redirection of the continuing work of the RMA Engineering Department to attack the problems of military radio equipment design and production. In this the entire organization of the Engineering Department has been expanded and reorganized.

Tube committees

The expansion has taken several directions. In addition to the work of the Committee on Receiving Tubes and its various subcommittees, the Committee on Cathode Ray Tubes was reconstituted and reorganized to assist in development and standardization for military applications. Further, the Committee on Transmitting Tubes with its numerous subcommittees was organized, and the work of the RMA Data Bureau greatly expanded in each of these 3 fields of electronic devices.

Basic to this expansion of the work in the vacuum-tube field was the opportunity to give assistance to the military services by the personnel of the three committees and the long-established practices of the receiving-tube field.

The several tube committees have, during the last year, worked closely with the various branches of the military services and the work of the Data Bureau in the assignment of the tube types is closely coordinated with appropriate groups in the Army and Navy.

The Committee on Receiving Tubes has continued its work in the development of standardized methods for tube testing of especial interest to the Army and Navy. In this and in other work, it has assisted in the development of the joint Army and Navy specifications.

Army-Navy specifications

The Committee on Cathode Ray Tubes was constituted of the committee originally established by the Radio Branch of the Bureau of

Ships. It has continued the work begun by that committee in the further production and development of the cathode ray tube types specifically planned for application to military equipment. In parallel with this work of design and research, the committee has worked most closely with the military services in the development of specifications for cathode-ray tubes with respect to new and important characteristics. This work has contributed to the establishment of a limited number of standardized preferred types being called for by the services as well as providing much of the basis for the joint Army and Navy specifications for cathode ray tubes. In this work the Data Bureau continues to be the centralized coordinating center for type designation assignment and registration.

Rationalizing transmitting tubes

The Committee on Transmitting Tubes has been at work on the problem of rationalizing the vast array of transmitting tubes which

are of interest and importance to the governmental agencies as well as on the problems of standardization with respect to new tube types still in process of development.

One subcommittee on transmitting tubes has made an exhaustive canvass of the several thousand tube types known to have found application for transmitting purposes and on the basis of this survey, has centered attention on the several hundred types of current importance. It has prepared publications which, for the first time in the history of the industry, bring together in one document, the briefly identifying data on all of these types. It has laid the ground work for the elimination of confusion resulting from the appearance in the field of substantially or completely identical tube types under distinct designations. It has provided for the dissemination of information on the characteristics of all tube types of present interest. In this the Data Bureau has performed its usual function of assignment and registration of tube type designations for all of the twenty U. S. manufacturers of transmitting tubes, as well as the added function of collecting and providing for the publication and centralized distribution of identifying characteristic data on important transmitting tube types.

Data Bureau

Operations of the Data Bureau are based on agreements as to a suitable type designation system developed jointly by the Committee on Transmitting Tubes and interested governmental agencies. Under the specific instructions of the committee and of the interested governmental agencies it is also gathering technical data on all pertinent types. It thus plans to bring about that same degree of rationalization of transmitting tubes which has characterized receiving tubes.

In June, 1942, the directors of RMA took action to make eligible for membership in RMA those manufacturers who are more largely

(Continued on page 106)

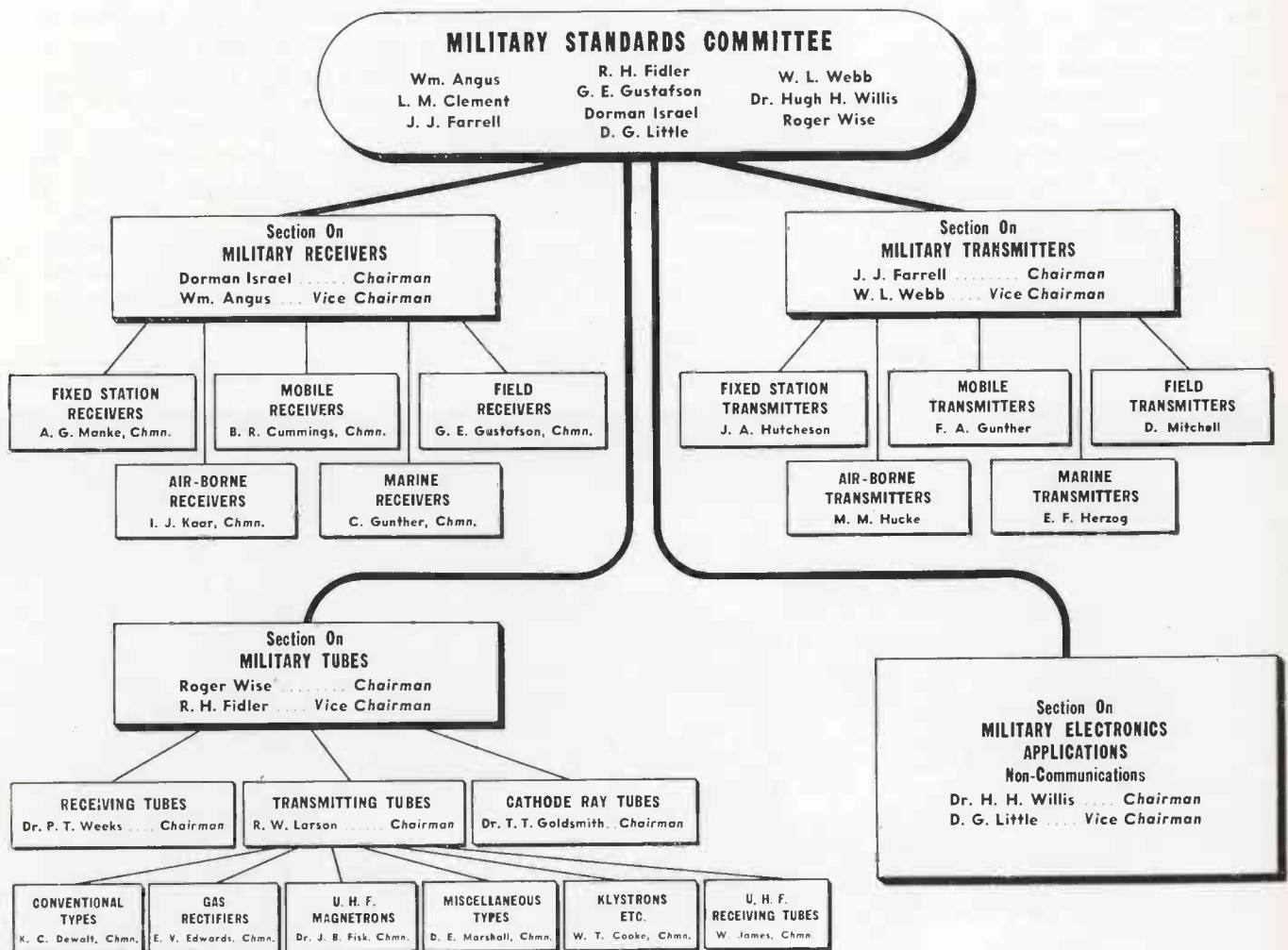

FACTORY SHORT CUTS

Lights at angle reduce glare

At plant of Superior Tube Co., Norristown, Pa., girls cutting tiny polished metal tubing 20 to 30 thousandths inch diameter, into 1/32 to 1/4-inch lengths, experienced bad glare from shiny surfaces when new fluorescent lights were installed. Superior's J. C. Crosswell investigated experiences in other plants in Philadelphia Area and found that turning fluorescent lamps 45 deg. to longitudinal axis of cylindrical work had solved similar problem in machine shops. Shifting fluorescents in Superior cutting room eliminated glare and stepped up cutting of the tiny cylinders, millions of which go into military electronic tubes.

Compressed air helps girls

Frail girls are doing work formerly performed by husky male mechanics in New Jersey plant which has equipped its shops with system of tubes carrying compressed air. This air service is piped to cylinders and bellows at all work positions where heavy mechanical pressure or holding effort was previously required of workers. In many cases, simple bellows mechanisms provide for securely holding

work which would otherwise be too heavy for female workers. Now, Maisie merely pushes button valve and summons muscles of a Dempsey. Air-bellows system comes in especially handy operating heavy press drills and maintains correct pressure on the cutting edges. By means of valve, measured pressure is continuously applied to press home drill, correct force having been pre-adjusted by using size of bellows which would complete drilling most rapidly.

Simplifying test procedure

Newton's laws of motion hold good for human mental attitudes as well as for physical masses. In almost any plant, techniques and methods lag behind changes in general conditions, and skeptical analysis of many operations will suggest simplification of old-established procedures. Kenneth Long, 22-year old special tester in RCA's Audubon, N. J., plant, wondered why signal generators worth \$435 were used in production-testing of government electronic equipment when, he reasoned, crystal oscillator costing only \$80 would do job just as well. He was right. So far, thirteen of these low-cost oscillators have been put

into service, freeing signal generators for more specialized work.

"Intercom" for noisy plants

Two-way 'phone equipment developed by Bell Laboratories has solved serious problem in at least one airplane plant. Welding instructors formerly had to shout, and students had to stop work and lift their hoods in order to penetrate high noise level. Much lost time was the result. Using throat microphones of the type supplied tank and aircraft crews, this communication problem was solved. Boiler factories have nothing on modern aircraft assembly lines.

Suggestion drives

Awarding cash prizes for acceptable suggestions from workers has resulted, for some plants, in greatly speeded production. As many as 50 per cent of suggestions made have been worth adopting. GE worker suggested use of low power induction heating instead of gas burner to solder crystal-holder shells, completely eliminating problems previously caused by deposition of moisture from gas flame inside the shell, and by frequent fractures of crystals due to heat conduction. In

CLOSE-UP work is facilitated with combination fluorescent lamp and lens

MADISON BUTLER, Stromberg-Carlson inspector who was honored by President Roosevelt, with one of his simplified testing panels





▲ **INFRA-RED** removes residual moisture from ink and paper, in design and drafting rooms at Westinghouse Bloomfield plant, permits erasure of pencil without lightening ink



▲ **TUBE-SEALING** speed was doubled by switch from horizontal lathe to vertical outfit which holds tube stationary while torch cluster revolves, at Westinghouse Lamp Division



▲ **FLAWS** in heat-treated steel parts show up as non-uniform magnetism if part has been magnetized while rotating at high speed. Oscilloscope sweep is "in sync" with rotation, to locate defect

TESTING of multi-terminal oil → transformers was speeded by this jig devised by John S. Corson, RCA Victor employee. As shown, one simple operation replaces up to fifteen previously required, to attach test wires or clips. Simplified, single-operation test-methods are vital to war effort. Production-line testing can be vastly speeded, even though green or unskilled workers are involved, if easy "go no-go" test jigs are engineered

1941 GE paid out \$95,205 for 12,453 accepted suggestions from employees. With labor and materials shortages upon us, savings in production time and materials consumption are vital.

Another example

Another RCA worker, Edwin Tracy, devised simplified application of an oscillator to test aircraft electronic equipment in the field. Previously, planes flown to distant fronts were delayed from going into action until apparatus could be removed from aircraft and tested, which took many hours. With oscillator, apparatus need not be removed from plane. Electronic altitude equipment is now tested at rate of one bomber every three minutes.



FIXTURE to permit quick, efficient assembly of terminals on transformer-can lids. Demonstrated by David W. Smith, another RCA Victor employee to ← win a suggestion-award

ENGINEER, LEADER and TEACHER

Dr. Wheeler, new President of IRE, paid high tributes by his former students, now outstanding figures in radio

Dr. Lee de Forest

5106 Wilshire Boulevard
Los Angeles, Calif.

As one of Dr. Wheeler's early pupils at Sheffield, Yale, 45 years ago, I have always held him in high esteem and kindly regard. One of my greatest satisfactions, through my long years in wireless and radio, has been the knowledge that I was putting to use the theories which Dr. Wheeler and Prof. Harry Bumstead had sought zealously, both by precept and example, to inculcate within my mind.

I have been pleased to note that Dr. Wheeler has stayed loyally by radio, and am now delighted that the Institute has formally recognized his sterling worth and contributions by electing him president.

Roger B. Colton

Major General, Army of the United States
Chief, Signal Supply Services

I am glad to note that Dr. Lynde P. Wheeler, formerly my instructor at the Sheffield Scientific School, Yale University, and since that time long my friend, is the new President-elect of IRE.

Dr. Wheeler was an inspiration to all his students, and since leaving Yale it has been my pleasure to encounter him while he has been discharging the duties of many important positions.

The Institute is fortunate in having an individual with Dr. Wheeler's rich experience and background as its leader.

James A. Code, Jr.

Major General, U. S. Army
Assistant Chief Signal Officer

It gives me great pleasure to learn of Dr. Wheeler's IRE honors. I am sure the experience he has had as a member of the faculty of Yale University and the staff of the Federal Communications Commission will

be reflected in his guidance of the future of the Institute of Radio Engineers.

John V. L. Hogan

Consulting Engineer
President WQXR, New York

When I was studying at the Sheffield Scientific School of Yale University, in the Class of 1911, Dr. Wheeler taught us electrical engineering. He was then, as he is now, a man well liked by every one, and recognized as knowing his stuff. He is the third Sheffield man to become President of the Institute of Radio Engineers, and we all salute him!

"Wheeler Alumni" Send Greetings

Among Dr. Wheeler's many distinctions is the large number of his students who have gone on to conspicuous accomplishments in later life.

To mark Dr. Wheeler's induction into the presidency of IRE, the editors of "Electronic Industries" invited brief expressions from a number of these "Wheeler alumni"—now notables in the radio and electronic fields. Their tributes to Dr. Wheeler are presented here.

Dr. Albert W. Hull

General Electric Research Lab.
Schenectady, N. Y.

It is a privilege to be able to join in tribute to a former teacher, for whom my admiration has grown continuously, and to pledge him support in this period when electronics has such a heavy responsibility.

Arthur Van Dyck

Retiring President IRE
Manager RCA License Labs., N. Y.

In these days of war emphasis on youth when the judgment of experience and age rates very low, and when they even say that flying pro-

iciency begins to dull at age 22, it is perhaps impolitic to call attention to anything involving way back when.

In spite of that, I am proud to say that some thirty years ago, I had a prof in the Scientific School at Yale whom I have never forgotten, and who now is the 1943 President of IRE.

Doc Wheeler knew his stuff then, and he knows it now. His students respected him then, and the whole radio profession respects him now.

G. L. Van Deusen

Brigadier General, U. S. Army
Fort Monmouth Red Bank N. J.

As a former student of Dr. Wheeler, it is most gratifying to bear witness to the great value of his work in training Army personnel in electrical communications, and to the high esteem in which he is held by all our officers who were so fortunate as to work under his direction.

C. M. Milliken

Brigadier General, U. S. Army
Washington, D. C.

I desire to extend my sincerest congratulations to Dr. Wheeler on his most deserved promotion, and to compliment the Institute of Radio Engineers on their commendable selection. I am most pleased that an organization so important to industry, and especially to the Armed Forces, is to have as its head one of my former outstanding instructors and esteemed friend.

Dr. John M. Miller

Naval Research Laboratory
Washington, D. C.

A "friend in need," Dr. Lynde P. Wheeler recommended the undersigned favorably for a Ph.D. degree at Yale in 1915. His twenty-seven subsequent years of distinguished service to radio science should atone

for this one mistake. The IRE makes no mistake in conferring upon him the honor of presidency.

Dr. Harry Nyquist

*Bell Telephone Laboratories
New York, N. Y.*

The Institute of Radio Engineers is fortunate in securing the services of Dr. L. P. Wheeler for the presidency. His varied academic and practical experience gives assurance that the interests of the Institute will be furthered during his term of office. As a former student of Dr. Wheeler I take pleasure in testifying to his abilities in the fundamentals of electrical sciences.

Dr. J. B. Johnson

*Bell Telephone Laboratories
New York, N. Y.*

For my friend and teacher, Dr. L. P. Wheeler, I wish the very best of felicity in his term as President of the IRE. The honor comes to him well-earned by his knowledge of the radio art, by his long service to it, and by his charming personal qualities. I am sure the IRE will prosper under his leadership.

Dr. Ross Gunn

*Naval Research Laboratory
Washington, D. C.*

It has been my great pleasure to know and work with Dr. Wheeler both at Yale University and at the Naval Research Laboratory.

Dr. Wheeler has always had unusual ability in arousing the interest and enthusiasm of his students in scientific research. Then after seeing they were well started, he would throw them on their own resources in a manner calculated to develop their ability as independent workers.

Dr. E. O. Lawrence

*Retiring President IRE
California, Berkeley, Calif.*

(Editor's Note: Dr. Lawrence, one of the most famous of the Wheeler Alumni, the celebrated "atom smasher" and builder of the great cyclotron, could not be reached in time to prepare a tribute to Dr. Wheeler. Word from Dr. Lawrence's office indicated that he was absent on an extended trip in connection with war work, and so no statement from Dr. Lawrence can be included at this time.)



DR. LYNDE PHELPS WHEELER

As 1943 opens, Dr. Lynde Phelps Wheeler becomes president of the Institute of Radio Engineers. Widely known among radio men for his many contributions to radio communications, Dr. Wheeler is now stationed at Washington, D. C., as chief of technical information of the FCC's Engineering Department.

Dr. Wheeler was born in Bridgeport, Conn., July 27, 1874. He was graduated from Yale's Sheffield School of Science in 1894. He remained at Yale until 1926 as professor, this period being interrupted only by his service in the Navy during the Spanish-American War.

He also served during World War I while remaining at Yale, where he organized and set up the course for Signal Corps Officer Candidates School in 1918. He is co-author of the text "Principles Underlying Radio Communications," as well as many articles and reviews on physical optics, thermodynamics, electrical theory, metallic reflection in various media, radioactivity, high-frequency alternating current, thermionic vacuum tubes, and other subjects.

In 1926 Dr. Wheeler joined the scientific staff of the Naval Research Laboratory. He spent most of 1929 and 1930 with various units of the U. S. Fleet, conducting radio experiments on aircraft carriers and in submarines at Panama, Hawaii and other places.

In 1935, President Roosevelt created a Science Advisory Board to aid government departments and Dr. Wheeler was persuaded to serve on the council. In July, 1936, Comdr. T. A. M. Craven, of the FCC, invited Dr. Wheeler to accept his present position with the FCC.

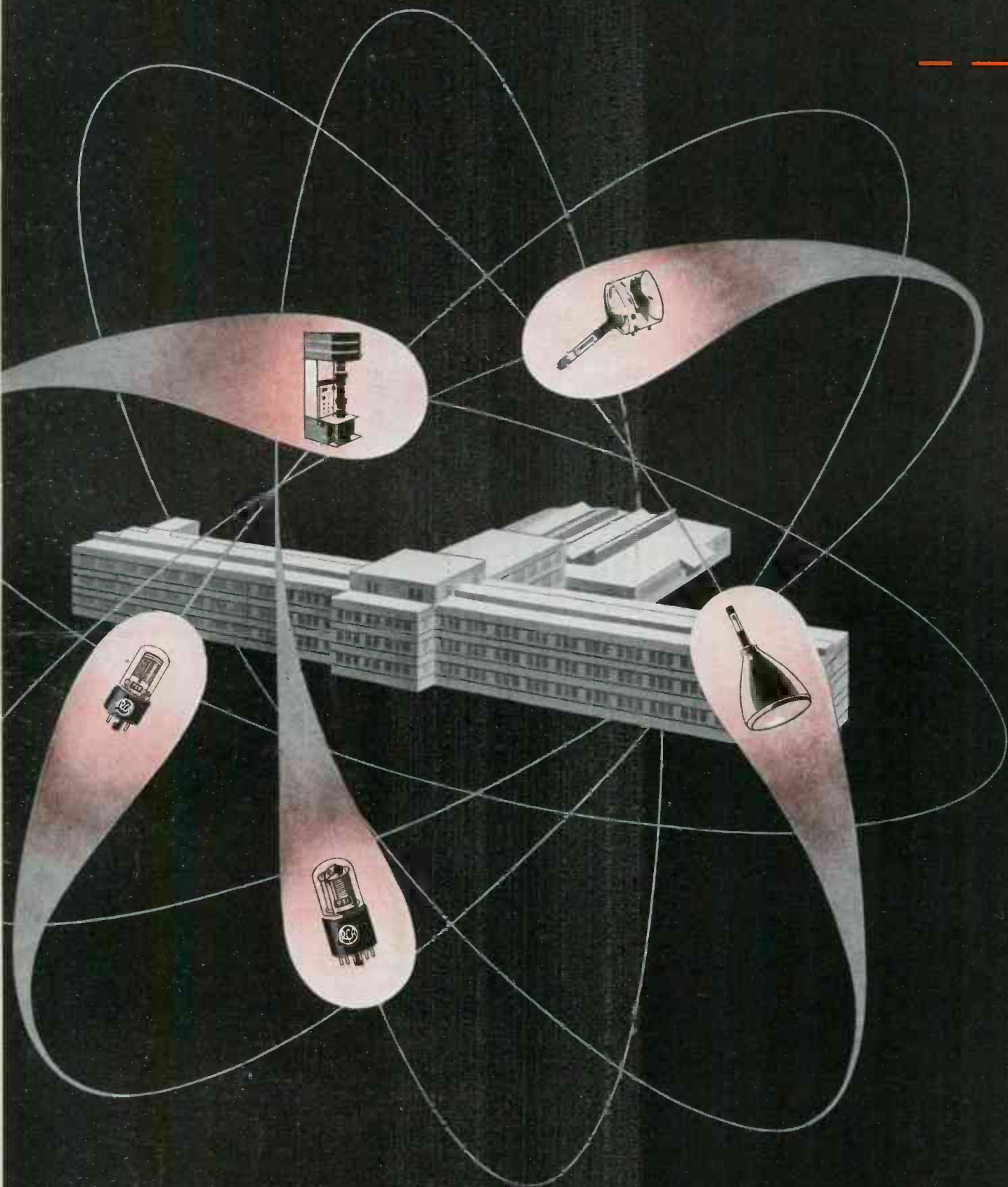

Just as the electrons of an atom are held in their orbits by the mysterious force of the nucleus . . . so the material results of research are controlled and directed by the central force of research exemplified in the new RCA Radio - Electronic Laboratories.

THE HIDDEN BATTLEFRONT

When the RCA Radio-Electronic Laboratories . . . stretching 488 feet from wing to wing . . . were dedicated last November, the Chief Signal Officer of the Army called them the "Hidden Battlefront of Research."

Hidden . . . because from that day to the end of the war, this magnificent new building, housing 150 laboratories, will be closed to all but the scientists and research technicians now working there on a myriad of heretofore unsolved radio-electronic problems . . . many of vital importance to our military effort.

The staff of these laboratories has already produced outstanding developments in new

radio, television and electronic devices, in ultra-short waves, in acoustics and in many other branches of electronic research . . . The skills thus developed before the war are now finding direct use in military applications with our fighting forces.

Out of the ashes of war these scientists will bring forth implements for a new and better civilization to serve the cause of a Victorious peace.

In the meantime . . . while working day and night for Victory . . . they are cooperating with other companies in solving problems that will help the war effort.



RCA LEADS THE WAY

IN RADIO • IN TELEVISION • IN ELECTRONICS

*RCA Manufacturing Company, Inc.
Camden, N. J.*

NEW UHF LANDING

First complete installation operates on 109.9 megacycles. "Glide-path" and runway localizers using instruments



The greatest problem in flying today is that of successfully and safely landing a plane under adverse weather conditions or low ceilings. It is now comparatively easy for a modern transport plane or a huge bomber to take off and fly uninterruptedly to the "vicinity" of its destination through any kind of thick weather and at most any altitude. However, it is extremely hazardous to land without mishap if only the standard equipment of radio range and flight navigation instruments are used under conditions of low ceiling and poor visibility.

From fifteen to twenty minutes are required to make a landing at a busy airport after the plane has been cleared to land by the airport traffic control tower. Concurrently, other commercial planes arriving at the cone of silence over the range station are compelled to circle at various altitudes and each await its turn to land, often consuming an hour or more before making a landing. If the flight has been long or the fuel is low the problem becomes more critical. Ever since aircraft entered the commercial

transport field and began to operate on scheduled flights, the dream of the transportation companies has been to establish air transport on a parity with railroad schedule timing with no loss of time in starting, moving and stopping upon a timetable which would not vary a second. The bottleneck of this whole idea has been the problem of aircraft landing.

Lateral and vertical guides

The Civil Aeronautics Authority has endeavored to overcome this difficulty by fostering the development of a suitable instrument landing system utilizing ultra short radio waves which give both lateral and vertical guidance in addition to position and altitude fixes.

To effect precise landings with a minimum of effort on the part of the pilot of the plane, long and varied experience has shown that four elements are advantageous, namely: A Localizer to furnish lateral Guidance. A Glide Path to provide the course of descent. An Outer Beacon Marker, and an Inner Beacon Marker.

The purpose of an instrument landing system is to provide a guiding path into the airport, which an approaching airplane may follow to a safe landing during conditions of poor visibility. The path must be well defined and easy to locate and should lead the ship in a natural glide to the approach end of the runway. In order to give the pilot ample time to orient the airplane in preparation for landing he should be able to locate the course some reasonable distance from the airport. The radio pathway to meet these requirements is analogous to a long chute sloping downward to the runway which the pilot could use as a guide by keeping the ship's wheels in contact with the invisible floor of the chute.

This vertical guidance or "glide path" is provided by a path of constant electric field intensity which

↑ Control panel of the new instrument landing system is explained to Field Director Haslett by Victor Barden, chief of traffic control

↓ Layout of air port equipment for a single direction, showing outer-marker transmitter, also inner marker, glide-path and localizer transmitters

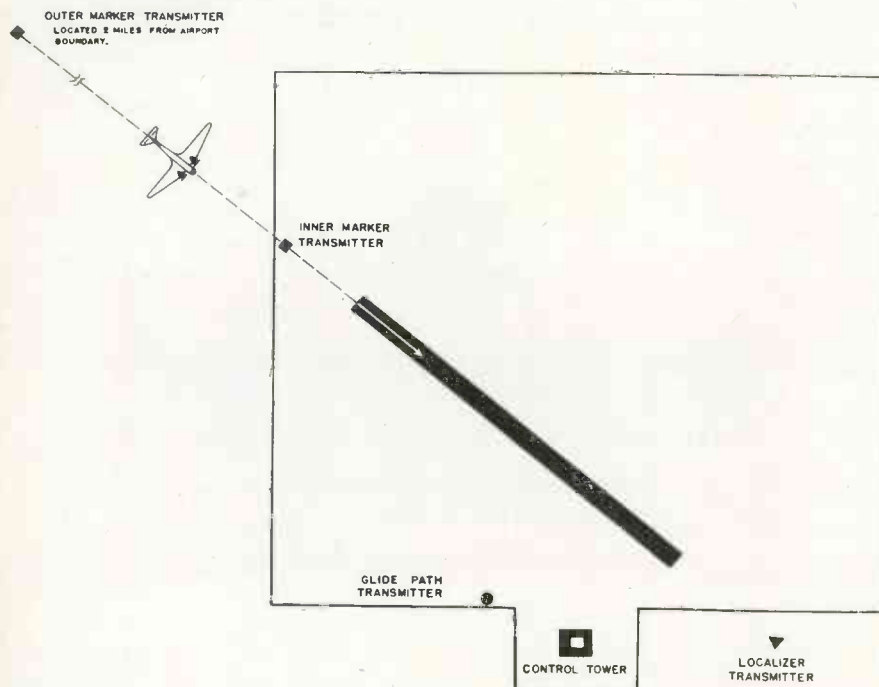

SYSTEM AT LAGUARDIA

closely approximates the natural glide path of an airplane from a point about five miles from the airport of the boundary of the runway. The glide path transmitter at the airport traffic control tower furnishes the ultra high frequency power for this service and a specially designed transmitting antenna establishes the constant field intensity along the path. The sides of the etheric chute provide horizontal guidance by restricting the lateral motion of the airplane so that it maintains a straight course to the runway.

Localizer field

The Localizer field for this lateral guidance is produced by a "runway localizer" transmitter and antenna installation located off the end of the runway at the airport. Two overlapping horizontal field patterns, each shaped similar to a kidney bean, as shown in the accompanying illustration, produce the localizer course. Each pattern is modulated with a different audio frequency and the course which the plane follows lies within the overlapped region where a 90-cycle tone and a 150-cycle tone of equal intensity is received by sight from flashing colored lights and from audible sounds from each pattern. The marker beacon control head from which these signals are received is located near the center of the instrument board in front of the pilot. A few inches to the right of the marker lamps is located the cross-pointer instrument which is a simple dial indicator and is gov-

erned by the constant field intensity "glide path" and the "runway localizer" which translates to the pilot the location of his flying ship in relation to the condition and distance on the ground below. This small round dial contains two indicating radium-painted needles, one positioned horizontally and the other vertically. The "guidepath" receiver operates the horizontal and the "runway localizer" receiver operates the vertical needle. The pilot

need only control the altitude of his airplane so as to maintain the "glide path" needle in a constant horizontal position in order to follow the glide path to the runway. If the glide path needle rises above the horizontal line, the airplane's position is above the correct glide path and vice versa if the needle drops below the horizontal.

Holds needle vertical

The vertical or "runway localizer" needle provides the pilot with lateral guidance to the airport runway. The pilot need only control the lateral position of the ship so as to maintain this needle in a vertical position to follow the course of the runway. Thus, it is only necessary for the pilot to maneuver his plane so as to keep the two needles crossed at right angles in the center of the instrument to bring the airplane safely to the runway in a normal glide and make a three-point landing.

The two overlapping patterns in the radiated field give side indications of the guiding path which are

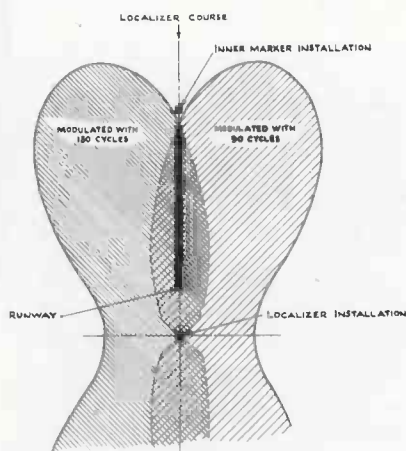

↑ Overlapping horizontal field patterns which produce runway-localizer course



↑ "Inner marker" at LaGuardia airfield, located at start of landing runway. Projecting its radio energy upward, this marker gives pilot a final quick instrument check



← This long shed-like structure houses the landing antenna which defines exact line of approach for pilot

so intense and accurate that the beam may be easily located at distances of twenty miles from the airport boundary and the course may be picked up at a distance of seventy miles from the airport while flying at an elevation of 4000 feet or over.

The inner and outer marker beacons are two narrow radio beams located on the ground along the course of the chute which send waves straight upward to be received by the pilot as he passes over them. One beacon is located two miles from the airport boundary and the other is at the airport boundary. These ultra high frequency waves form the elliptically shaped beam with the longer dimension of the ellipse at right angles to the course.

Crystal control

The localizer installation is generally placed between 500 and 1,000 feet off the end of the runway and the glide path installation is usually 1,300 feet off the center line of the runway and about 1,000 feet forward from the end. The rated output of the localizer transmitter is 300 watts, unmodulated, on a frequency of 109.9 megacycles, operates from 220 volts single phase, 60 cycles. It is crystal controlled and the crystal oscillator tube functions also as a frequency multiplier. These fre-

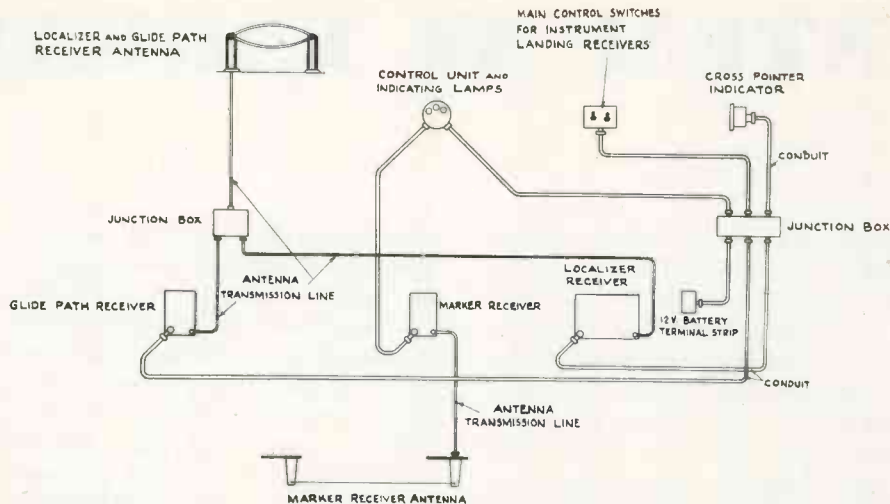

↑ Typical assembly of receiving equipment in the airplane, for new instrument landing system

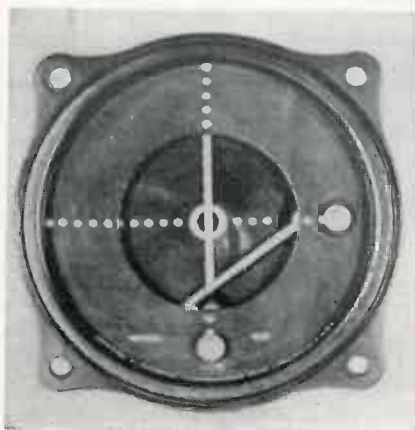

↑ Cross-pointer indicator



↑ Marker-beacon receiver for mounting in instrument panel of airplane equipped for instrument landing

quency multiplier stages follow the crystal oscillator tube to produce the output operating frequency. In order to raise the output of the final multiplier to the rated transmitter output level, the last two stages are push-pull amplifiers operating on the output frequency.

The marker beacon installations consist mainly, of a small waterproof aluminum house situated alongside of a wire screen counterpoise 20 feet square over the center of which is located two half-wave radiators mounted end to end. The wire screen is supported by an angle framework and also mounted above the ground on angle legs. Concentric gas filled transmission lines joining the waterproof house with a matching box located between the ends of the radiators, are used for feeding the marker transmitter output to the radiators.

The airport tower is equipped with a monitor and control desk
(Continued on page 107)

← The cross-pointer indicator as installed in the plane instrument board is shown below arrow, together with associated plane instruments



WAR PRODUCTION SHIPMENTS

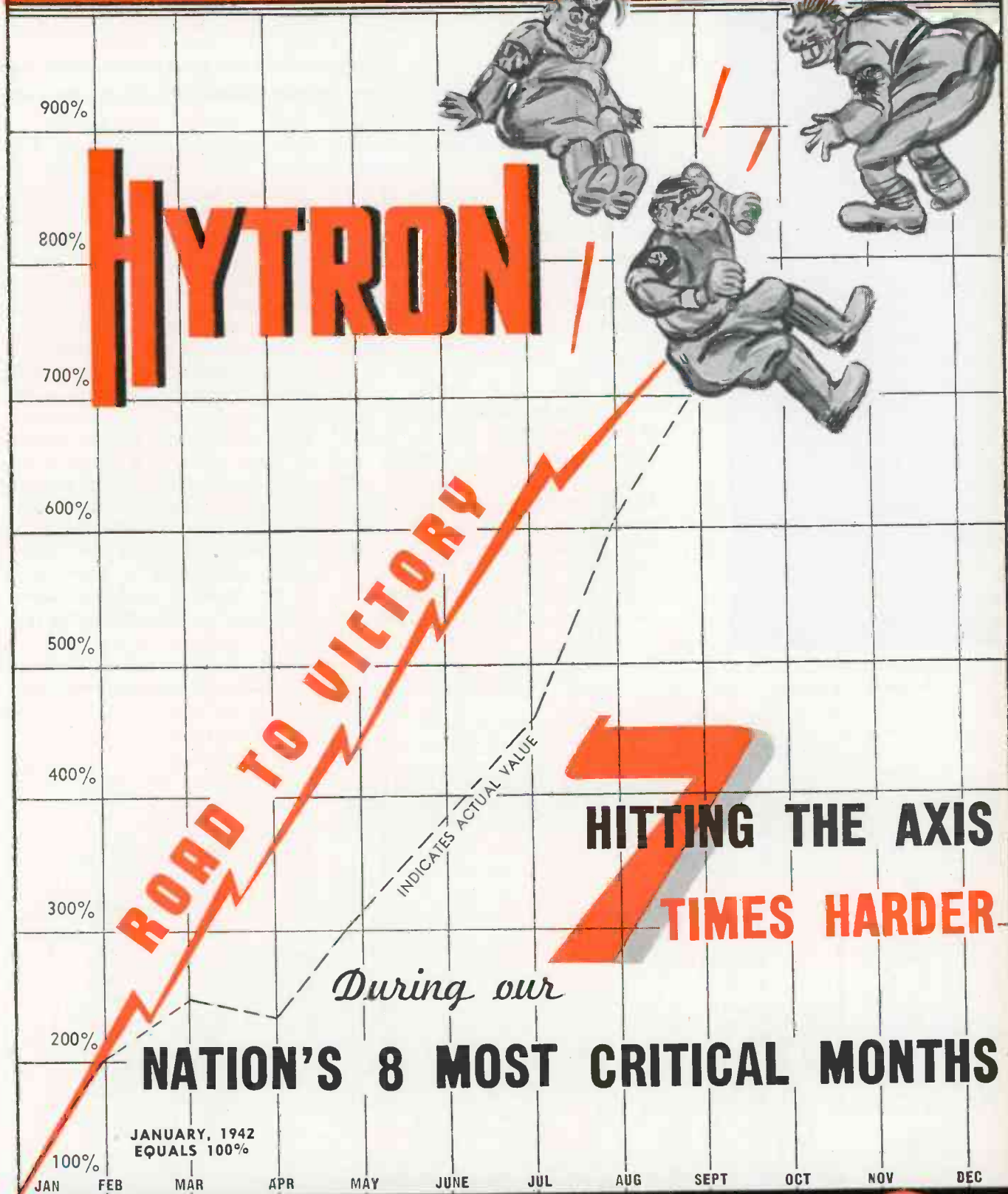

HYTRON CORP., Salem and Newburyport, Mass.

... Manufacturers of Radio Tubes Since 1921 ...



50-kw FM AT W55M

by D. W. GELLERUP

Chief Engineer W55M and WTMJ

Circuit line-up and modulator operation at Milwaukee's Radio City

Frequency-modulation transmitters with powers in the 50-kw range are still comparatively few. Major Armstrong's famous Alpine, N. J., station pioneered the way with its 40-kw power, which continues in operation. The Zenith 50-kw FM transmitter went into service at Chicago more than a year ago.

And in New England, Yankee Network's Paxton transmitter is a widely known 50-kw station.

Now, under the initiative of one of broadcasting's most intrepid engineering pioneers, Walter J. Damm, chief radio executive of The Milwaukee Journal (WTMJ), a new 50-kw FM transmitter has gone into service to serve the rich Milwaukee area.

The transmitter of The Milwaukee Journal FM station, W55M, is

an R.E.L. 50-kw installation. Even before getting its 50 kw, W55M was a pioneer in FM service in the mid-west, and though tubes and other parts are now on the shortage list, no decrease in operating time is being planned. The current schedule of 10 A.M. to 10 P.M. is being maintained seven days per week.

The heart of the Armstrong system of frequency modulation is, of course, the modulator. This modulator is divided into five major parts. The audio section consists of three 6C5's in a stage of resistance-capacity coupled amplification. A phase inverter is used for driving two 6P5GT's in push-pull, which in turn are transformer-coupled to the screen grids of the balanced modulator tubes. This equipment along with the pre-

General circuit arrangement of phase shift FM modulator

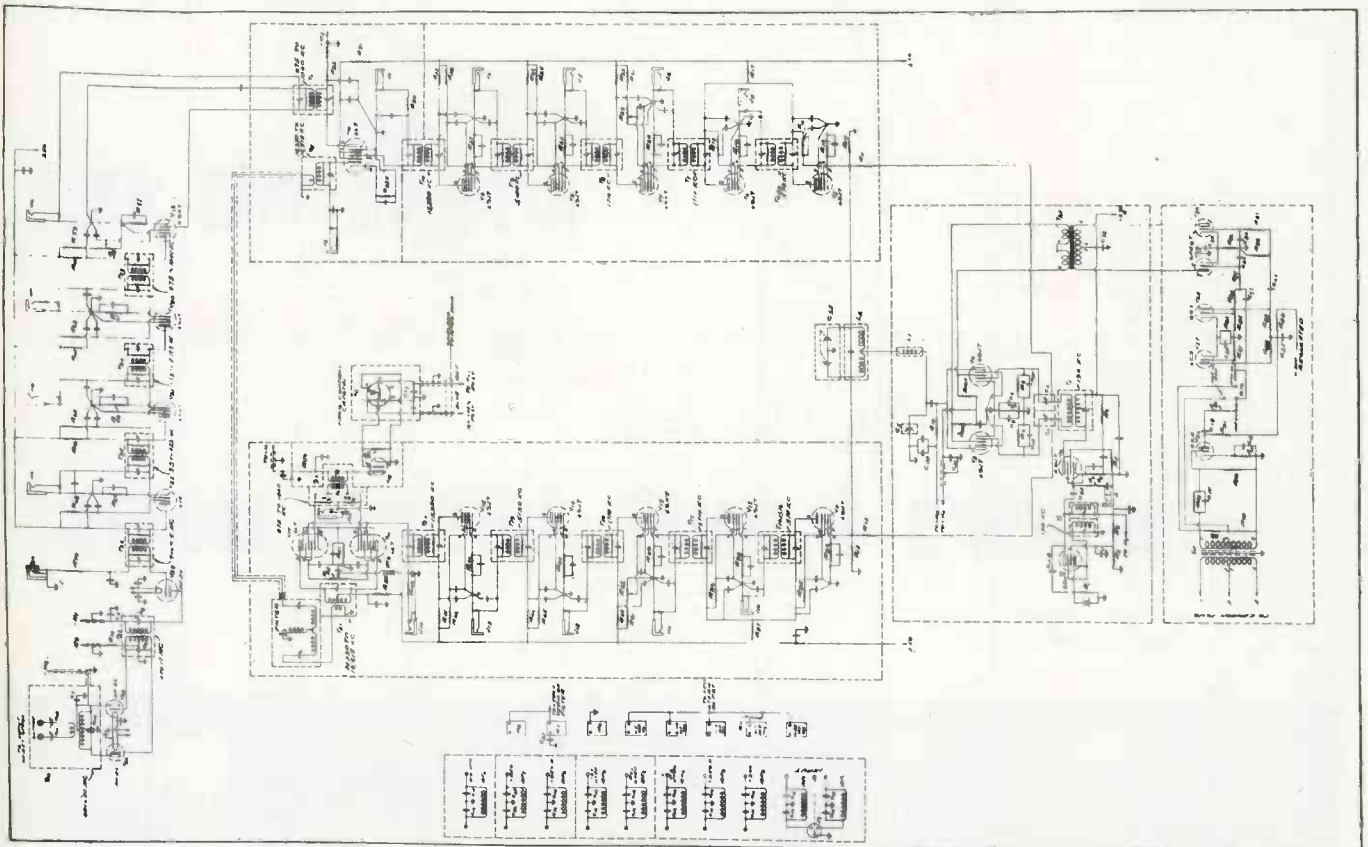

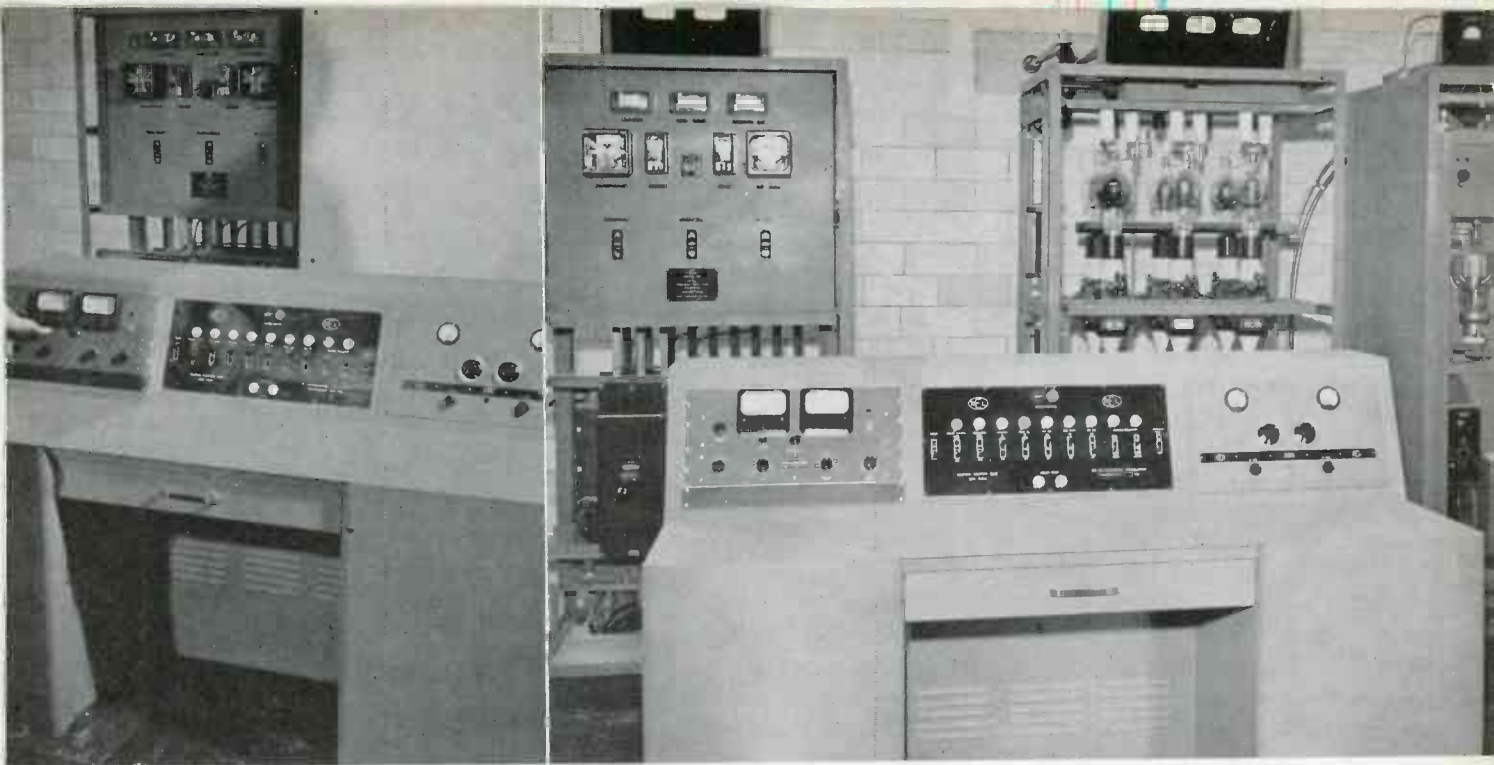

Control console, transmitter power supply and final stage amplifier

emphasis network, and corrector associated with phase shift modulators, is located at the bottom of the modulator panel.

A 190-kc crystal oscillator and associated parts are mounted directly above the audio circuits. The oscillator consists of a 6SJ7 (VI) as the oscillator, and this excites another 6SJ7 (V2) as a buffer amplifier. This buffer stage supplies the rf excitation for the two modulator control grids and the carrier energy for the two multiplier channels. Two more 6SJ7's (V3, V4) are used as the balanced phase modulators and are also mounted on this panel.

Frequency multipliers

Directly above the modulator tubes on each side lie the two multiplier channels, terminating in 6L7's used as converters. Each channel consists of five tubes as follows, 1—6SJ7 as a tripler, a second 6SJ7 as another tripler, a 6SK7 as a buffer with variable screen voltage control, a third and fourth 6SJ7 as triplers. This last multiplier drives into a pair of 6L7 converter tubes in the right-hand channel and a single 6L7 in the left-hand channel. Both channels are identical up to the converters. The diagram of this modulator is shown. The frequency of energy entering the converters is 15,390 kc. This is the original crystal fre-

quency multiplied eighty-one times, and this signal is impressed on the second set of control grids in the 6L7's. On the first set of 6L7 control grids, energy from a second crystal is impressed. These two frequencies mix and the plate circuit is tuned to the resultant frequency or frequency difference. Note the fact that the second crystal frequency is always the output frequency divided by 48, thus at an output frequency of 48 mc the crystal frequency would be 1 mc. (At

W55M's frequency of 45.5 mc the second crystal frequency is .94791 mc). The frequency difference between 15,390 kc and 1 mc would be 14,390 kc.

To converter tube

This energy is coupled into the left-hand converter tube (V10) where it mixes with the 15,390 kc energy coming up the left hand multiplier chain. The frequency difference of these two sources (1 mc) is fed to the top of the panel

Frequency response characteristic of W55M



where it is multiplied 48 times and used to drive the power amplifiers at the assigned frequency.

The above example shows that only the second crystal determines the output frequency of the modulator. If the 190-kc oscillator should drift up in frequency 1 kc, the resultant frequencies at the right-hand converter tube would be 15,471 kc and 1 mc from the second crystal. The frequency difference would be 14,471 kc. This is fed over to the left-hand converter and mixed with the 15,471-kc energy coming up from the left-hand channel. The difference is again 1 mc and if multiplied by 48 again gives us the operating frequency of 48 mc. If the frequency of the first oscillator drifts too far the amount of energy getting through the multiplying stages will not be sufficient to operate the system. This possibility is eliminated by the use of heat-regulated low-drift crystals.

Modulation action

The output channel consists of the following; one 6SK7 buffer, one 6SJ7 doubler, one 6SJ7 doubler, one 6V6 doubler, one HK24 power doubler and two HK24 as push-pull trip-

plers which form the output stage of the modulator.

Now it has been shown that the output frequency of the modulator unit, due to the mixing process described before, is independent of the 190 kc oscillator. By the same mixing process, if one multiplier channel is modulated in a positive frequency direction, while the other channel is modulated in a negative frequency direction, the output frequency will change in accordance with the incremental frequency shift at each channel. This action produces frequency modulation at the output frequency. The balanced modulator located in the lower center of the main panel does this shifting of the frequency in a positive direction of one channel, and in a negative direction to the other in accordance with the audio modulation.

Operating characteristics

Starting from the 190 kc oscillator, the exciting source, the tube V2 (6SJ7) is driven and in turn excites the control grids of the balanced modulator tubes V3 and V4. The buffer stage V2 also supplies the 190 kc carrier energy to the two

multiplier channels. Due to the fact that the two channels are differentially modulated there is a gain in apparent phase shift and the distortion at low audio frequencies is kept well within requirements. This also reduces noise somewhat.

The characteristics of the new modulator are as follows: The measured signal to noise ratio is of the order of 70 db below 100 per cent modulation. The measured distortion at 50 cycles is of the order of 1 per cent, at 100 cycles it is about five-tenths of 1 per cent, and above 100 cycles the distortion drops off so rapidly that accurate measurements are difficult to make. The frequency response is flat within 1 db from 50 cycles to 15,000. The frequency stability is extremely good and stays within several hundred cycles of the assigned frequency.

The modulator is mounted on a hinged vertical panel and is easily accessible for service and adjustment. This panel as well as the necessary rectifiers and power amplifiers to complete a 250 watt unit are housed in one frame.

The output of the 250-watt unit

(Continued on page 106)

Circuits of power amplifier unit for Milwaukee's new 50-kw FM transmitter

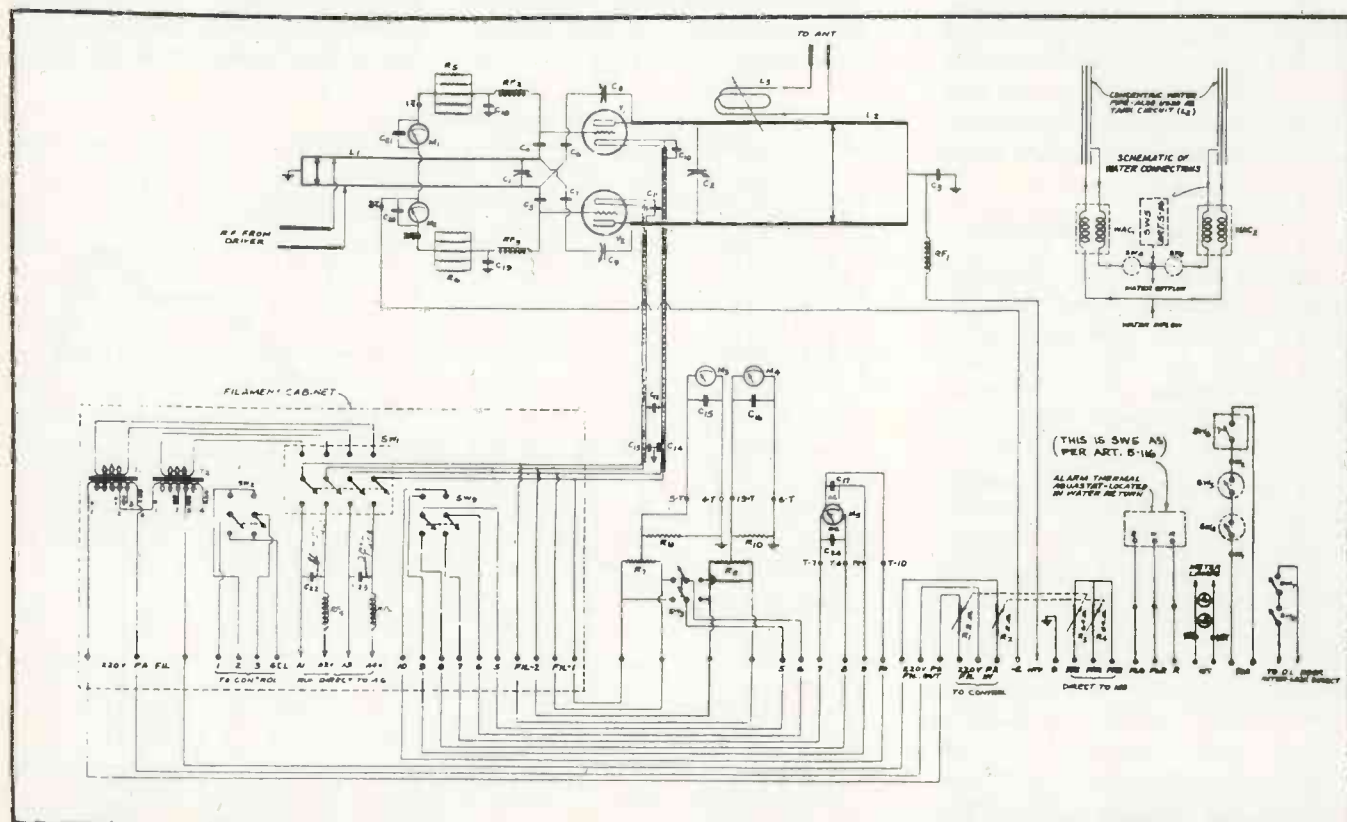

PRINCIPLES OF SHORT WAVE RADIATION - I

by DR. ERNST WEBER

Professor of Graduate Electrical Engineering and Head of Department, Polytechnic Institute of Brooklyn

The principal concepts of electromagnetic radiation particularly at very high frequencies are introduced by using the approach from transmission line theory. It is shown that radiation is predominantly a terminal effect and that application of electromagnetic theory at once gives characteristic impedance, radiation pattern, radiation resistance, input impedance and losses of antennas. Emphasis is placed on the clear distinction of the basic concepts and on the importance of "matching" at points of discontinuities to avoid standing waves which always presage obstructions to transmission of power. The role of conductors is shown to be that of mere guides that concentrate energy in the dielectric surrounding them. The high frequency fields penetrate extremely slightly into the conductors which absorb just enough to cover their joule losses. Quantitative relations are given wherever feasible, with a minimum of mathematical development.

Basis of conventional transmission line theory

It is always a pleasant feeling to return home to familiar surroundings. This is true also in studying and in the exploration of unfamiliar regions. Let us therefore use the ordinary, conventional, two-wire line as our home surroundings and explore it as a "guide" to radiation phenomena.

Assume a comparatively long line as in Fig. 1, with dc or low frequency ac voltage applied. At any point z along the line, we presume that we can measure current i with an ammeter and voltage v with a voltmeter in the conventional way. Two basic assumptions are involved in this procedure, firstly that the manner of connecting between the voltmeter and the two opposite points on the line is irrelevant, and

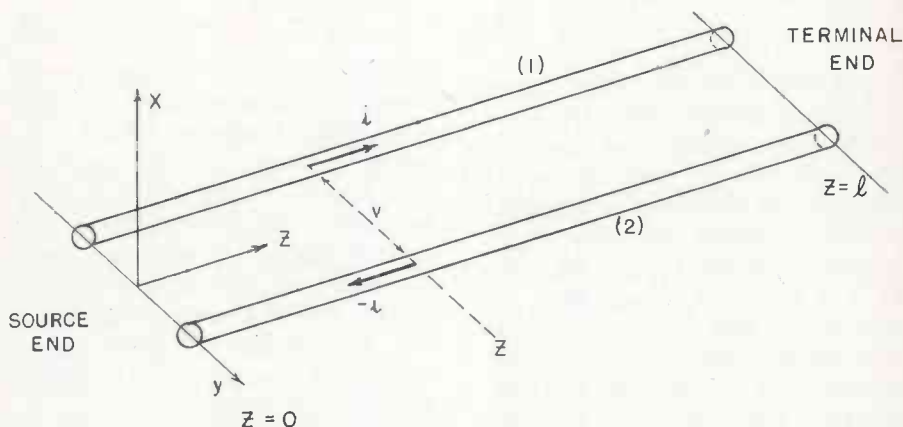

Fig. 1. Conventional two wire transmission line

secondly that all the transmission current flows in the two wires in opposite direction.

In a little more theoretical manner, this can be also stated as assuming that each cross-section perpendicular to the transmission system gives exactly the same field configuration, namely, that shown in Fig. 2. The wire to the left, carrying current out from the source, has higher potential than the opposite wire bringing current back from the terminal. There will then be an electric field \mathbf{E} between the wires such that all the field lines emerge perpendicularly from the surface of conductor 1, which assumes positive surface charge, $+q$ per unit length; and terminate perpendicularly on the surface of conductor 2, which assumes a negative surface charge, $-q$ per unit length. This electric field in air (or any other dielectric) gives rise to the usual parameter of shunt capacitance of the line per unit length, defined by

$$C = q/v \quad (1)$$

It is actually a field identical with the one obtained from electrostatics where one assumes that each wire has the same potential all along the transmission line. Since the voltage drop along the line is usually held to very small values

(small attenuation) compared with the voltage across the line, that assumption is close to the facts. As an electrostatic field, the vector \mathbf{E} is then defined as "voltage gradient" by the line integral between two opposite points on the wires

$$\int_1^2 \mathbf{E}_s ds = v \quad (2)$$

where this integral can be taken along any arbitrary curve in the plane of Fig. 2, and where \mathbf{E}_s is the component of \mathbf{E} along the path element ds . Therefore, voltmeter leads can take any arbitrary form, the instrument will always read the same value at low frequencies.

The two wires are also surrounded by magnetic field lines, which, as long as the wire diameters are less than about $1/7.5$ of the distance d between wire centers, can be represented as eccentric circles as shown in Fig. 2. According to fundamental principles, one can define the magnetizing force \mathbf{H} by the line integral

$$\oint \mathbf{H}_s du = i \quad (3)$$

meaning that the closed line integral of \mathbf{H} (\mathbf{H}_s is the component along the path element du) measures the total current i through the path. One frequently calls this line integral also magneto-motive force

F. Using the Giorgi system of units, **H** is given in amperes per meter (or amperes per centimeter), where

$$\frac{4\pi}{10} \text{ ampere per centimeter} =$$

$$1 \text{ oersted} = 1 \text{ gilbert/cm.}$$

Obviously, the magnetic field contributes the series inductance of the transmission system, which is obtained from the total magnetic flux ϕ_m between the conductors by

$$L = \frac{\phi_m}{i} \quad (4)$$

But this is not all. There must also be an electric field within the conductors, driving the current. Since at dc or low frequency voltages, the current will distribute rather uniformly over the cross-section A, its density will be given by $J = i/A$. The voltage drop per unit length will then be Ri , where R is the resistance per unit length; and since $R = \rho/A$, with ρ the resistivity, one also has per unit length

$$\frac{\rho}{A} i = \rho J = E_z \quad (5)$$

which is again a "voltage gradient," but now in the direction of the transmission line. The electric field within the conductor, therefore, accounts for the joule losses due to the finite resistivity. For ideal conductors, i.e., zero resistivity ρ (infinite conductivity δ), no electric field exists within the conductor, and the electric field lines can only terminate perpendicularly on its surface. The idealization to infinite conductivity, though admittedly not corresponding to facts, is a convenient means to simplify many problems particularly at high frequencies.

Finally, the current flowing within the conductor must even there be surrounded by magnetic field lines, though now the lines do not link with total current i . One can on the basis of "magnetic linkage" define an internal inductance per unit length L_{int} , so that the total inductance of a transmission system always appears as the sum of two terms:

$$L_{total} = L_{ext} + L_{int}$$

external inductance, defined by (4), and internal inductance, which is usually rather difficult to find, but fortunately small compared with L_{ext} so that crude approximations can be made.

The electromagnetic field carried by transmission line

Considering the line in Fig. 1, we can state the current voltage relations, if we disregard both resistance and leakage, in the simple form

$$-\frac{\partial i}{\partial z} = C \frac{\partial v}{\partial t} = \frac{\partial q}{\partial t} \quad (6)$$

$$\frac{\partial v}{\partial z} = L \frac{\partial i}{\partial t} = \frac{\partial \phi}{\partial t} \quad (7)$$

This simply states that the rate of change of current along the line equals the charging current between the wires and that the rate of change of voltage along the line equals the "induced emf" or the rate of change of magnetic flux. All quantities are referred to unit length, L and C being inductance and capacitance per unit length and q and ϕ charge and magnetic flux per unit length.

Both equations combine into a single one by differentiating (6) with respect to t and (7) with respect to z .

$$\frac{\partial^2 v}{\partial z^2} = -L \frac{\partial^2 i}{\partial t \partial z} = LC \frac{\partial^2 v}{\partial t^2} \quad (8)$$

which is mathematically known as the "wave"-equation. One simple solution can easily be found to be

$$v = V_0 \sin \omega (t - z \sqrt{LC}) = V_0 \sin \left(\omega t - \frac{2\pi z}{\lambda} \right) \quad (9)$$

where $\omega = 2\pi f$ is the angular frequency applied to the system,

$1/\sqrt{LC} = W$ the velocity of propagation along the line, and $W/f = \lambda$ the wavelength of the field along the line. Equation (9) represents a traveling wave of voltage from sending end towards receiving end. It is important to note that λ depends upon the shape of the conductors and the general field distribution, since it contains both L and C which can be evaluated directly from a plot such as that in Fig. 2. For most practical purposes with air as dielectric medium, the velocity W is almost identical with c , the velocity of light in free space, and then λ becomes independent of the configuration, namely $\lambda = c/f$.

The current follows now easily from the relation (7) by using the first form of (9) and disregarding any constant arising from time integration, as

$$i = \frac{V_0}{\sqrt{L/C}} \sin \left(\omega t - \frac{2\pi z}{\lambda} \right) \quad (10)$$

Obviously, this current is exactly in phase with the voltage and has exactly the same distribution along the line. The ratio

$$\frac{v}{i} = Z_0 = \sqrt{L/C} \quad (11)$$

is the characteristic impedance of this lossless line and is again simply determined by the field configuration, as for example that of Fig. 2.

Since we have found that each cross-section has the same field distribution, and since the current and voltage are uniquely defined by the

Fig. 2. Transverse field of transmission line

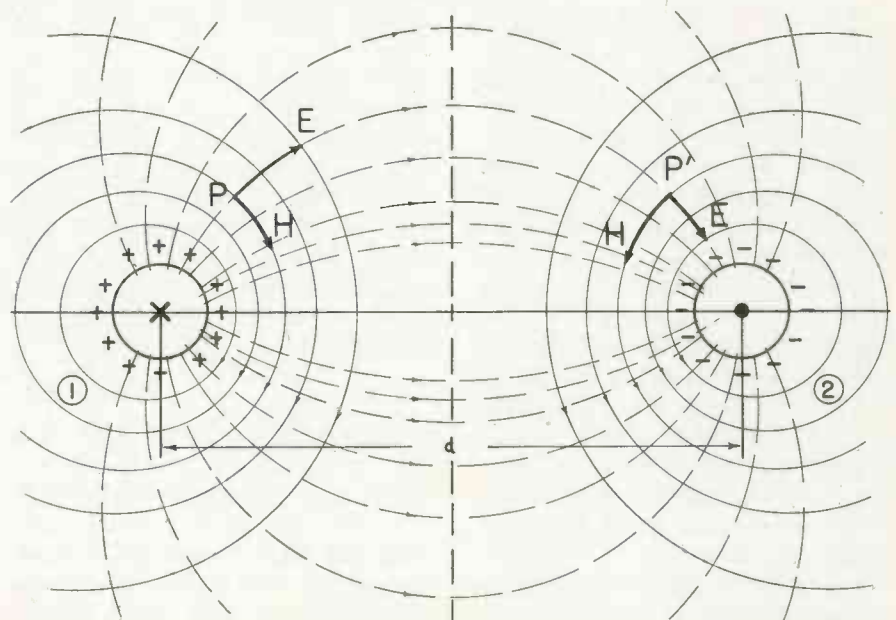

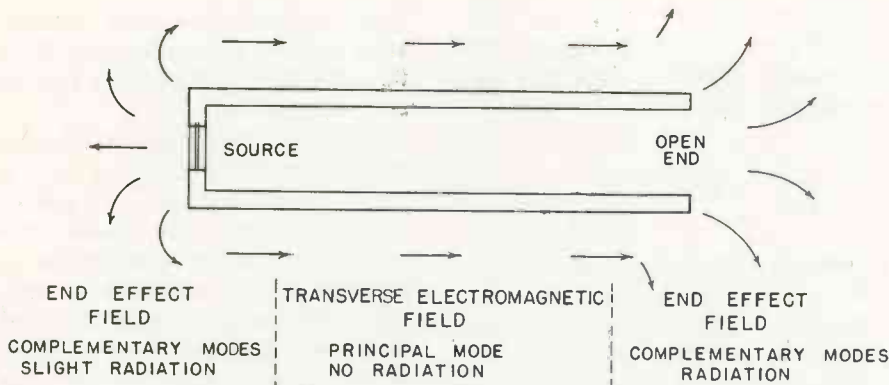

Fig. 3. Guidance and radiation of power by transmission line

integrals (2) and (3), we must conclude that with this current-voltage wave moves, rigidly fixed to it, or better still, as the detail mosaic of it, an electromagnetic field distribution, for which we can state

$$E = F(x, y) \sin\left(\omega t - \frac{2\pi z}{\lambda}\right) \quad (12)$$

Here, $F(x, y)$ is the actual vector value of the electric field, which of course, varies from point to point in the cross-sectional plane but for the same point is constant all along the z -direction. An explicit solution for $F(x, y)$ would involve two components E_x and E_y and would have to be found from Maxwell's field equations.

The magnetic field vector must have a similar form as the electric field vector, for example

$$H = M(x, y) \sin\left(\omega t - \frac{2\pi z}{\lambda}\right) \quad (13)$$

where $M(x, y)$ now represents the vector value changing from point to point in the cross-sectional plane. However, at any one point, the ratio of the two absolute values

$$\frac{E}{H} = \frac{v}{i} = Z_0 \quad (14)$$

must be the same as that of voltage and current, because the integrals (2) and (3) can be taken not only over any arbitrarily selected field line, but over any arbitrary path whatsoever! It is thus possible, to define for the plane wave which moves as the detail electromagnetic structure of current and voltage, the characteristic impedance of transmission in the same manner as one conventionally does for the line quantities⁽¹⁾.

Although it is comparatively easy to develop a picture of the electro-

magnetic waves accompanying any line configuration, it is usually rather difficult to obtain the detail solutions from Maxwell's equations. Indeed, it is amazing to realize that every possible field solution should grow out of the two simple vector equations that Maxwell set down in 1864 and which we shall just quote for completeness' sake, in the appendix.

Now, the solutions (9) and (10) only represent a wave progressing in the positive z -direction, outward on the line. Mathematically, another pair of solutions is possible.

$$v_r = V_r \sin\left(\omega t + \frac{2\pi z}{\lambda}\right) \quad (15)$$

$$i_r = \frac{V_r}{\sqrt{L/C}} \sin\left(\omega t + \frac{2\pi z}{\lambda}\right) \quad (16)$$

which obviously represent a current-voltage wave progressing in the negative z -direction, or backwards towards the sending end of the line. Physically, it must be a reflected wave, since we have assumed no source at the terminal end of the line. It is significant that the reflected current wave has the opposite sign of the outgoing wave.

Again of course, we must associate with this current-voltage wave a detailed electromagnetic field structure, a "reflected" electromagnetic field, moving towards the source-end of the line, which looks exactly like Fig. 2 but for which the same sign reversal must hold for the magnetic field as for the reflected current. Now the ratio

$$\frac{v_r}{i_r} = Z_r = -Z_0 = \frac{E_r}{H_r} \quad (17)$$

indicates that the characteristic impedance of the reflected wave is the negative value of the outgoing

wave! It is imperative to note that the impedance concept as "characteristic impedance" pertaining to transmission has sense only for a progressive wave and must be designated as positive or negative depending on the direction of progression.

The general transmission line solution is the superposition of outgoing and reflected waves, which, in terms of voltage, leads to

$$v = V_0 \sin\left(\omega t - \frac{2\pi z}{\lambda}\right) + V_r \sin\left(\omega t + \frac{2\pi z}{\lambda}\right) \quad (18)$$

and the same must hold for the electric field vector E . The result of the superposition is in the conventional notation a "standing" wave.

$$v = (V_0 + V_r) \cos \frac{2\pi z}{\lambda} \sin \omega t - (V_0 - V_r) \sin \frac{2\pi z}{\lambda} \cos \omega t \quad (19)$$

which has a maximum value at $z = 0, \lambda/2, \lambda$, etc.

$$v_{\max} = \pm (V_0 + V_r) \sin \omega t \quad (20)$$

and a minimum value at $z = \lambda/4, 3\lambda/4, 5\lambda/4$, etc.

$$v_{\min} = \mp (V_0 - V_r) \cos \omega t \quad (21)$$

The absolute ratio of maximum to minimum values is defined as the "standing-wave ratio,"

$$s = \frac{|v_{\max}|}{|v_{\min}|} = \frac{V_0 + V_r}{V_0 - V_r} \quad (22)$$

Exactly the same relations hold for the electric field vector E and in exploring standing waves on slotted sections of lines, the probe actually measures an incremental voltage

$$V_{\text{probe}} = \int_{\text{probe}} E_s ds \quad (23)$$

according to relation (2). Obviously, the direction and shape of the probe have considerable influence, since only the component of the electric field vector along the surface of the probe can enter the integral.

Guidance of power by the transmission line

The power passing through any cross-section of the transmission system as given in Fig. 1 is conventionally measured as vi and can be expressed with (9) and (10) for the forward wave as

$$P_o = v_i = V_o \sin \left(\omega t - \frac{2\pi z}{\lambda} \right) \frac{V_o}{Z_o} \sin \left(\omega t - \frac{2\pi z}{\lambda} \right) \quad (24)$$

The forward wave transports then an average power

$$P_{oav} = \frac{V_o^2}{2Z_o} \quad (25)$$

in the positive z-direction, out along the line towards the terminal end. This power is not carried uniformly but varies between a maximum of twice this average and zero, twice in the interval of a wavelength.

With the aid of the two basic relations (2) and (3) one can reformulate (24) as the product

$$P = v_i = \left(\int_1 E ds \right) \times \left(\int_1 H d\mu \right) \quad (26)$$

where the integrals are to be taken along an electrical and a magnetic field line, respectively. Instead of performing both integrations independently, over each set of field lines, one can combine them into integration over an area, since the

field line sets are mutually perpendicular. Define $(ds du) = dS$ as a surface element, then one can write (26) also as

$$P = \iint E H dS \quad (27)$$

where now the integration is to be performed over the entire cross-sectional area of the dielectric surrounding the two conductors, i.e., over the entire plane shown in Fig. 2, excepting the wire sections. One can now take the view that the product EH locally gives the power per unit area flowing in the direction of the transmission systems. In fact, Poynting⁽²⁾ in 1884 introduced as vector of power flow density

$$N = E \times H = nEH \sin(E, H) \quad (28)$$

where n is the unit vector normal to the plane defined by the electric and magnetic field vectors. In fact, the three vectors E , H , n , follow each other in the same manner as x , y , z , coordinate axes in a right-handed system. This generalization is of extreme value in all ultra-high

frequency problems, since it gives a vivid and unique description of the flow of power from a source through space to the load.

Applying this new concept in more detail to the forward wave on the transmission line, we observe first that both the electric and magnetic fields are strongest on the surfaces of the conductors. Since, as shown above, E and H in the dielectric are essentially oriented in planes perpendicular to the wires, the Poynting vector (28) has the same direction everywhere in the dielectric space, namely, parallel to the wires in the direction of positive current. The power flow, therefore, follows the wires out to the load and is densest in their immediate neighborhood. What about the wires themselves? As we saw, in the wires there is only a longitudinal component of the electric field E_z , according to (5). Since the magnetic field arranges in circular field lines even within the conductors, we find the Poynting vector in both wires directed towards the axes! This means, then, that all the energy is transported in the dielectric, and that the conductors only absorb as much as they need to cover the joule losses. The wires act as guides and not as carriers of the electric power. It has to be emphasized that this holds according to Maxwell, irrespective of the frequency of the field. This is even true for dc power transmission!

For the reflected current-voltage wave and the associated electromagnetic field we find with (15) and (16)

$$P_r = v_r i_r = - \frac{V_r^2}{Z_o} \sin^2 \left(\omega t + \frac{2\pi z}{\lambda} \right) \quad (29)$$

or a negative power flow of average

$$P_{rav} = - \frac{V_r^2}{2Z_o} \quad (30)$$

which confirms that the reflected wave brings power back towards the source.

What will be the result of the superposition of forward and reflected waves? We know that a "standing" wave results according to (19). The total power flow is then

$$P_o + P_r = \frac{1}{Z_o} \left[V_o^2 \sin^2 \left(\omega t - \frac{2\pi z}{\lambda} \right) - V_r^2 \sin^2 \left(\omega t + \frac{2\pi z}{\lambda} \right) \right]$$

which can be rearranged as

World's Loudest Siren, Capable of 172 DB. See Chart in Supplement



This loudest noise-machine ever built, designed by Bell Laboratories and built by Chrysler, has been on tour visiting 40 cities. It delivers alarm warnings over areas from 10 to 130 square miles. New York, Detroit, Chicago and San Francisco have installed similar noise machines as basis of their air-raid alarms. Our sound-level chart supplement, accompanying this issue, shows output of this Chrysler-Bell Victory siren to be: Close-up, 172 db; at 100 ft., 136 db (threshold of pain, 130 db); at one mile, 100 db!

$$P_o + P_r = \frac{1}{Z_o} \left\{ (V_o^2 - V_r^2) \sin^2 \left(\omega t - \frac{z\pi}{\lambda} \right) - V_r^2 \left[\sin^2 \left(\omega t + \frac{z\pi}{\lambda} \right) - \sin^2 \left(\omega t - \frac{z\pi}{\lambda} \right) \right] \right\} = \frac{V_o^2 - V_r^2}{Z_o} \sin^2 \left(\omega t - \frac{z\pi}{\lambda} \right) - \frac{V_r^2}{Z_o} \sin \frac{4\pi z}{\lambda} \sin^2 \omega t \quad (31)$$

This last form shows clearly the first part as power transported in the positive z-direction, as outgoing power, while the second term gives a standing wave distribution of power just staying in space and not moving. In a transmission line wave, therefore, only the difference power of outgoing and reflected wave is really reaching the terminal, while the power of the reflected wave fills space with field energy just oscillating locally around the wires and lost for transportation. Obviously, all that has been stated explicitly in terms of current and voltage values could also be stated for the electric and magnetic fields at every point in space.

So far, we found only guidance along the wires and small absorption in the wires. Now, where does the power really originate, how does it get into space to then flow along the wires? Obviously, the conventional transmission line theory cannot give any answer in this respect, since it only describes the uniform transport itself. In order to learn the action of source and terminal of the line, one has to study the general field configuration near the ends of the line.

The end effects of a transmission line

Assume that the transmission line in Fig. 1 ends abruptly at $z = e$, with no "termination," open-circuited, as one might say. Along the line we found from conventional theory, everywhere the field pattern given in Fig. 2. Suddenly now, at $z = e$, the backbone of the transmission, the wires, are cut off. Whatever field extends beyond cannot possibly have the plane configuration. In fact, no matter what kind of termination we imagine, none, absolutely none, can continue the field pattern, except again an infinite line.

In order to evaluate the field extension in a reasonable manner, we have to turn to Maxwell's field

theory, in particular to the boundary conditions. Again we can get a good insight if we use the line concepts as a guide. Suppose we cut the transmission line at an arbitrary cross-sectional plane z , then the exposed cuts are completely characterized by current i and voltage v . Both these quantities must be the same on either side. But on account of (2) and (3) we can express this also as identity of

the electric field component E_z and the magnetic field component H_x within the boundary surface, since the line integrals can be chosen arbitrarily. One can generalize the boundary conditions by stating that the tangential (to the boundary surface) components of electric and magnetic field vectors \mathbf{E} and \mathbf{H} must be the same on either side of a boundary surface, no matter

(Continued on page 115)

Widely Known Radio Engineers Join Editorial Staff of "Electronic Industries"



FRANK BUTLER

• Frank E. Butler who has become associate editor of "Electronic Industries" has been active in radio from its very beginnings.

Back in 1904, with Dr. Lee deForest, he operated a wireless station at the World's Fair in St. Louis, the first high-power transmitter to communicate with Chicago. In 1906 he built the trans-Atlantic station at Manhattan Beach, N. Y., and sent messages to Alexander Graham Bell in Ireland.

As chief engineer he continued with deForest during the historic experiments culminating in the invention of the audion or three-element tube—the invention which laid the foundations for modern radio and electronics. Later Mr. Butler helped develop the wireless telephone, equipping 34 Navy ships under Admiral "Fighting Bob" Evans. He also assisted deForest in developing the sound-on-film technique, now known as talking motion-pictures.

Mr. Butler's other inventions apply to sound amplification, and in recent years he has occupied himself in writing a history of the growth of radio.



RALPH BATCHER

• Ralph R. Batcher who becomes consulting editor of "Electronic Industries" is a widely known radio engineer who has written many articles and text books on electronic subjects including special works on cathode-ray tubes.

Beginning as a radio amateur in Iowa in 1909, Batcher was graduated from Iowa State College in 1920. During World War I he served as instructor in radio theory at the Signal Corps School, CCNY, and also at the old Marconi Institute. From 1920-24 he was engineer with the Western Electric (now Bell) Laboratories at New York, then becoming research engineer with A. H. Grebe & Co. until 1928. In 1929-30 he entered the manufacture of loudspeakers, as vice-president of Decatur Manufacturing Co., resigning to do consulting engineering work until 1938 when he became chief engineer of Allen D. Cardwell Mfg. Co., a post in which he has continued during the war period.

Mr. Batcher is a member of the Board of Editors of the I. R. E. Proceedings. He is also active in the New York Society of Measurement and Control.



Marvin Camras of Armour Research Foundation, Chicago, and his invention, the iron-wire recorder, back and front of which are shown. Recorder differs from earlier types in its new form of recording head, indicated by the pencil

BC OPERATING METHODS

Wartime economies when men, materials and supplies are scarce

Magnetic-Wire Recording

Although efforts to record sound on wire were made as early as 1898 by Valdemar Poulsen, a Danish professor, his work, while it attained some degree of success, provided only a partial solution of the problem. A practical method for wire recording has now been developed by Marvin Camras, of the staff of Armour Research Foundation, Chicago, Illinois.

Poulsen's work led to the development of magnetic recording on tapes, but this method has its disadvantages. In the newly developed Armour technique, symmetrical recording around the center of the wire removes distortion resulting from rotation. The use of sharp variations in magnetism permits a slower speed and the use of one-fifth of the length of wire required with the Poulsen type of recorder. Steel wire of great tensile strength, .004 inch in diameter, provides a compact, relatively indestructible record. This is slightly larger than a fine blonde hair.

An advantage of magnetic records over other types is that they

require no processing after recording. In addition, they may be used indefinitely. Records forty years old are reported to be still usable, and magnetic recordings have been successfully played 200,000 times.

The recording wire is reusable and may be easily demagnetized for use for another recording. Theoretically, there is no limit to the length of recording that may be made by this type of machine. An eight-hour machine is now being constructed for experimental purposes.

The development at the Armour Foundation of a practical technique of wire recording is expected to permit wider exploitation of the known advantages of the wire method. Besides broadcasting, possible applications for such a machine include: military uses; home uses, for recording radio programs and telephone messages, family amusement; office purposes; industrial and scientific applications, in studying sound vibrations; in aircraft flight tests and routine recording of orders; in education, for studying speech difficulties and foreign languages; and in psychiatry.

"Pinging" of Power Tubes

Small power tubes are not seriously affected by time. But the larger types operating at anode potentials above 2 kv, may not operate satisfactorily at normal anode potentials without a seasoning process. J. S. Leigh points out that the failure of tubes to stand high voltage, often called "pinging," is usually due to cold emission from sharp metallic points. These points may be flakes of metal, minute filings, or other similar particles.

Handling or mechanical vibration of a tube may expose such points, causing "pinging" in a tube which previously operated satisfactorily at high voltage. The cold emission builds up cumulatively to electron emission and a metallic and gas vapor arc.

When tubes are operated at gradually increasing voltage the sharp points are successively melted down until the tube operates satisfactorily at normal voltage. A gassy condition may occur, but this is relatively rare. It will be evidenced by a glow, generally blue, from within the bulb upon initial application of voltage.

Constructing Convex Panels for Studio Walls

So much interest has been shown in the article appearing in the December issue of "Electronic Industries" (page 60) describing the installation of convex panels on the studio walls of broadcasting station WSPD at Toledo, Ohio, that we here picture additional construction details of these panels. A similar installation of convex acoustic panels is now being made in the studios of WLW, the Crosley station at Cincinnati, based on WSPD's experience.

The new system utilizes the acoustic dispersion theory recently developed by Dr. C. P. Boner of the University of Texas, which effectively eliminates dead sound, without destroying the brilliancy of hard walls. In several respects the idea is quite the reverse of accepted standards for treating studio walls, for instead of creating a "dead" studio by having padded or treated walls that blur and de-energize sound waves, the surrounding air in the five studios of WSPD is very much "alive", although there are none of the ill effects of reverberation present.

Acoustic dispersion

The new dispersion system provides for a series of hard, cylindrical surfaces of different curvatures, some running horizontal and others perpendicular, which break up delayed sound waves by directing them from surface to surface, thereby rendering ineffective any tendency to create relative effects into the live microphones.

Inasmuch as all studios are not of the same dimensions or height there can be no standard sizes of convexity form established to fit the physical limitations of every room. Therefore each installation must be figured out individually. The size of the studio is not so important as is its shape. This should conform, as nearly as possible, with the accepted ratio rule of height two; width three, and length five, or to be specific, if the ceiling is 16 feet high, the width of room should be 24 feet and length 40 feet. Having such dimensions of the room, plan upon making the polycylindrical panels approximately the sizes given in the chart on page 62 of last month's article.

One end of the room requires a series of these convex panels alternated as to size and running horizontally, the entire height of room. The opposite end of the room preferably should be flat, and treated with perforated acoustic board.

Coming now to the long sides of the studio, the length of the room on one side should be equipped with alternate convex panels of the two sizes running upright, but with perforated acoustic board on the lower portion about head high. The panels on the remaining side wall should run horizontally, the same as the one end first described, but should be staggered as to location.

Shaping materials

To shape the curved panels make a wooden form of light material of each size, having a length equal to

that of the entire length of the room. Follow the curved dimensions of the chart. Cut compo board to a width sufficient to make the arc. Then install inside the curve a series of half-circle segment braces, located at random distances from each other, cutting the overall length of completed panel to fit its particular location, and nailing the curved panel to the segment braces, varying the spacing of braces or partitions so that all hollows vibrate at the different resonance periods of each section of each panel.

The material used for the curved panel may be of plywood, masonite or any similar construction sheets capable of making a bend.

In the construction of these paneled walls the space in between the upright studding or scantling is filled with pads of fiber glass.

Studio panels of WSPD, Toledo, during construction. Compo board is bent on forms of the required curvature

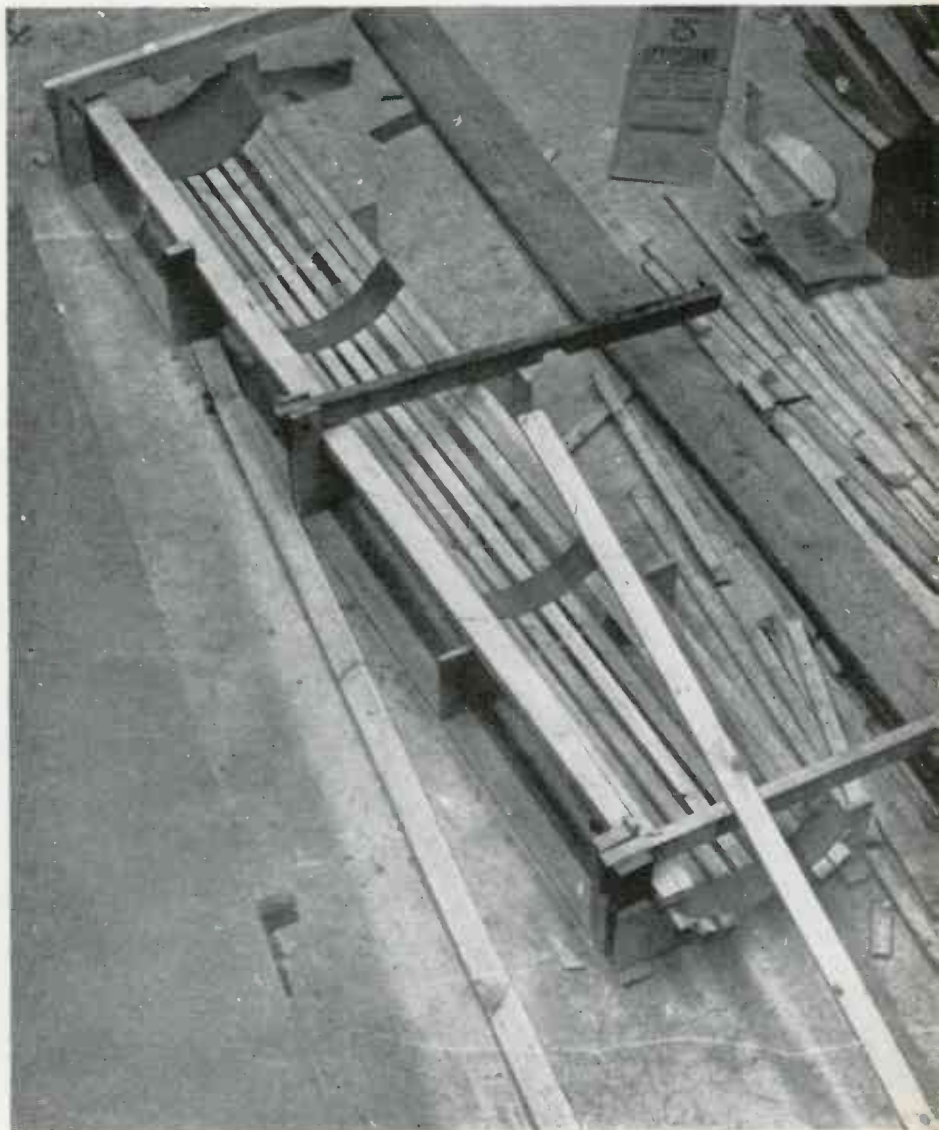

Electronic Tubes ON THE JOB



Calendulas created by use of X-ray

The X-ray Twins

"The X-ray Twins," Glowing Gold and Orange Fluffy, are the names of two new calendulas, flowers created electronically by the use of X-rays by David Burpee, president of the W. Atlee Burpee Company, Philadelphia, Pa. Seeds of two flowers called Radio and Sunshine were sent in 1933 to Dr. Goodspeed of the University of California for X-ray exposure treatment. Reselection continued for six generations until the two new calendula varieties were considered satisfactory for consumer use.

X-ray treatment is reported to bring about greater changes than colchicine, a drug long used by seed growers, to increase the number of chromosomes of a plant, thus intensifying or deteriorating predominant characteristics. X-rays are effective in smashing the genes and breaking up the chromosomes.

Growing Gold developed from Sunshine, has a color range between golden and orange, measures 4 in. across with loose and fluffy petals that give the appearance of a golden ball.

Orange Fluffy, developed from Radio, is a bright mid-orange, intensified by a jet-black eye.

Photocell-Operated Bomb Sight

An automatically operated bomb sight, in which a photocell causes release of the bomb when the cross hairs come on the target, is the subject of patent No. 2,299,313, issued to Franklin W. Durgin of Washington. The sighting tube carries a small lamp, which projects a beam of light against a mirror carried by the plane's speed indicating instrument. Thence the beam is projected against a second mirror on the altimeter and from there to the photocell on the release mechanism. All sighting adjustments are thus made automatic. Until the sight comes upon the target the light beam does not fall on the photocell. As soon as it does, the bomb is released.

Ocean Currents

The U. S. Coast Guard and Geodetic Survey has developed a radio current meter which broadcasts continuously and automatically the velocity and direction of ocean currents. The instrument, which is

called the Peters-Roberts meter after the two Survey officers who are chiefly responsible for its development, was designed primarily for use in areas where such strong currents prevail that difficulty is experienced in holding a vessel on station continuously for a long enough time to obtain data necessary for accurate prediction of future currents.

The radio transmitter translates the velocity and direction of the current into a series of dots and dashes that can be tuned in by the survey vessel or by a shore station and there recorded automatically on a waxed paper chronograph.

Helps Pillow Cases "Float Through the Air"

A unique automatic device for handling textile and laundry materials from conveyor to stack-pile by means of compressed air is being used in the Danvers Bleachery at Peabody, Mass.

Pillow cases come through a large ironer onto a conveyor belt. The difference in speeds between the conveyor belt and the ironer space the pillow cases from six to eight inches apart. The leading edge of the case on the conveyor interrupts a light beam and resets the

As the pillow cases come off rolls above, photocells turn on blasts of compressed air which cause cloths to stack neatly

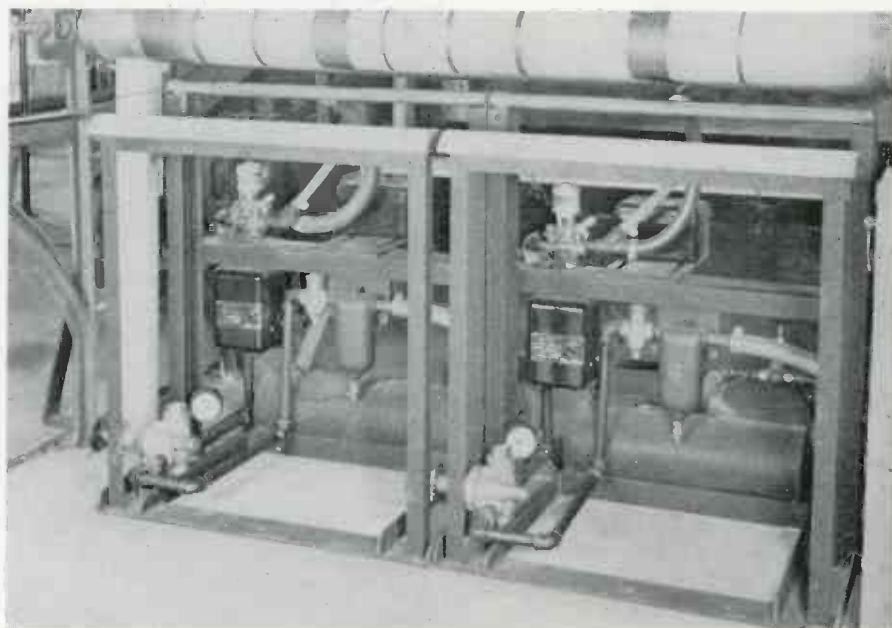



Pillow case leaving conveyor and being thrown over stacking rail

mechanism for an operation. As soon as the pillow case passes beyond the light beam and allows the light to strike a GE phototube, a solenoid valve is opened for a period of approximately 0.3 second. This time is controlled by the vacuum-tube timer. The opening of the solenoid valve allows air at approximately 15 lb. pressure to enter two horizontal perforated tubes. One tube blows air against the leading edge of the pillow case while the second tube blows air towards the lagging edge of the case, passing it to the horizontal bar which is the receiving rack.

Ordinarily a small percentage of the cost of a machine is represented in control equipment. In this case, however, practically 100 per cent of the machine is control, with the exception of the framework in which it is mounted, a regulating valve, air tank, and some piping.

Carrier Impulses Save Copper in Camps

A reduction of 85 per cent in the amount of copper used in systems to control outdoor and obstruction lighting and other electrical apparatus at three military bases in North Carolina, Virginia, and New Jersey, is made possible by the use of carrier-circuit equipment.

The impulse apparatus used at these military bases is similar to that already used by many electric power stations to control street lights and water heaters.

The equipment transmits impulses over the regular power lines of the military bases. These impulses are picked up by receivers which in turn operate relays to turn on or off the current flowing to electric lights, pumps, and other electrical apparatus. Use of this equipment at the military bases

eliminated the necessity of running many miles of separate lines of copper wire to control the various electrical circuits.

Precision Weighing for Blind

An "audio" scale enabling the blind to weigh rapidly and accurately and opening new fields of precision weighing to them, was demonstrated at the American Foundation for the Blind, 15 W. 16th St., New York City. The scale operates to give an audible signal "A" as long as the scale shows under the correct weight, and the signal "N" if it registers over. Correct weight is signalled by an unbroken buzz tone.

Alternating current of 1000 cycles flows in tuneable double branch circuit, with an earphone coupling transformer common to both branches. A motor-driven contactor switches the current alternately to the two branches so that the intermeshed "A" and "N" pulses are applied respectively to the minus and plus fixed plates of the scale indicator balancing condenser. At the desired weight, both signals are heard combined to produce a continuous signal.

In war plants, the scale has such uses as weighing out specific amounts of powder for fuses, mica for radio parts, and buttons for uniforms. Blind operators using it are able to package phonograph needles, 25 to 50 to a pack, more rapidly than by counting. It is also expected to prove useful to sighted persons who have to work in the dark, as in film plants, or who must



Blind girl is able to weigh accurately by listening for continuous tone

concentrate on such operations as filling narrow-mouthed containers to a net weight content.

J. O. Kleber, electronic engineer of the Foundation; H. D. Bennett, president of the Toledo Scale Company, Toledo, Ohio, manufacturers of the scale; and Lawrence Williams, chief engineer, directed the demonstration at the Foundation.

How the scale tone operates. Overweight sounds Morse N; underweight A. Exact balance combines A and N into continuous tone

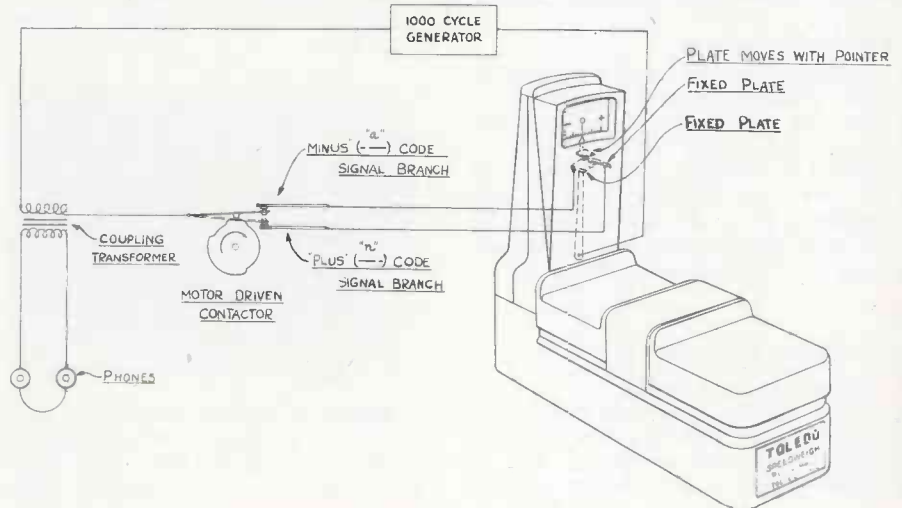

WHAT'S NEW

Devices, products and materials the manufacturers offer

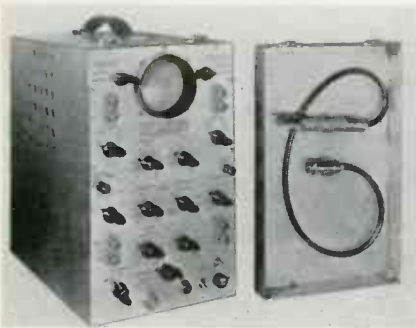

Cathode-Ray Oscillograph

The cathode-ray oscillograph type 224, manufactured by Allen B. DuMont Labs. Inc., 2 Main Ave., Passaic, N. J., has a uniform vertical deflection response covering a range from 20 cps. to 2,000,000 cps. The amplifier for the horizontal deflection has a uniform characteristic from 10 cps. to 100,000 cps. Both amplifiers are also said to have distortionless input attenuators and gain controls. In addition to the conventional amplifier connections, signals can be applied directly to the deflection plates.

The instrument weighs 49 lbs., and measures 14½ in. x 8¾ in. x 15½ in. It operates on 115 volts, 60 cycles per second.

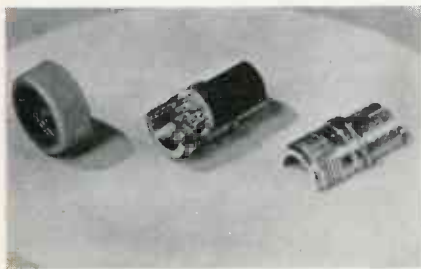

Cable Connector

A new electrical cable connector that eliminates one coupling nut and one barrel, providing a three piece, split-shell construction, is now in production at the Harwood Co., 747 N. Highland Ave., Los Angeles, Cal. The connector is of die cast construction and conforms to Army-Navy specifications.

Sectional Resistor

A sectional resistor for use in railway service, radio circuits, power rectifiers and laboratories in connection with ac or dc of 250 to 30,000 volts, is introduced by the

Westinghouse Meter Division, Newark, N. J. Adjacent sections carry the wire winding in opposite directions for non-inductive operation. The individual units have values of 0.25 to 1 megohm and a rated current of 1 ma. Assemblies for switchboard mounting are available in 7.5, 15 and 30 kv. sizes. The dimensions are 1¾ by 1¼ in. in diameter per section.

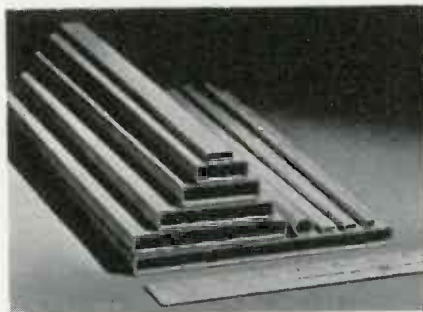

Paper Tubes

Paramount Paper Tube Co., 800 Glasgow Ave., Fort Wayne, Ind., announces that new arbors make possible quantity production of paper tubes from 3/16 inch to 4 inch square inside with a tolerance of 0.002 inch for coil forms and other uses. The paper tubes can be supplied in dielectric kraft, fish paper, red rope, acetate or combination wound and in square, round or rectangular shape.

Standard Laboratory Equipment

Standard laboratory equipment of the Wheatstone bridge and decade resistance box categories are announced by Industrial Instruments, Inc., 156 Culver Ave., Jersey City, N. J.



Standard models, resistance decades, are available with resistance ranges of .9 to 999,999 ohms total. All coils are of manganin wire

excepting the 100,000 ohm coils of nichrome. All coils are bifilar-wound on ceramic tubes, oven-baked and protectively-coated.

The Wheatstone bridge, illustrated, contains four resistance dials with nine positions each, covering 9 x 1, 9 x 10, 9 x 100, and 9 x 1000 ohms, with decade multiplying dials. The ratio resistances have a guaranteed accuracy of plus/minus .05 per cent, while the resistance coils in the decades of the bridge are guaranteed to plus/minus .1 per cent tolerance. The galvanometer is of the well-proven moving-coil type with sensitivity of 1 microampere per division.

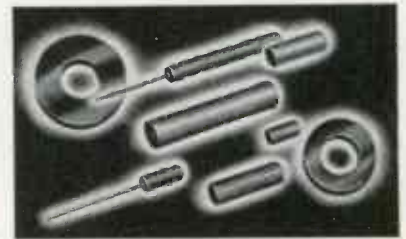

Iron Cores

New materials recently developed by the Stackpole Carbon Co. of St. Marys, Pa. have resulted in the introduction of molded iron cores which are claimed to show outstandingly favorable characteristics at frequencies as high as 150 to 175 megacycles. These iron cores combine a permeability of approximately 5 with high Q. All engineering samples are made on the same equipment that is used in actual quantity production.

Synthetic Sapphire

Synthetic white sapphire, unpigmented corundum of gem quality, is available in the form of boules from the Linde Air Products

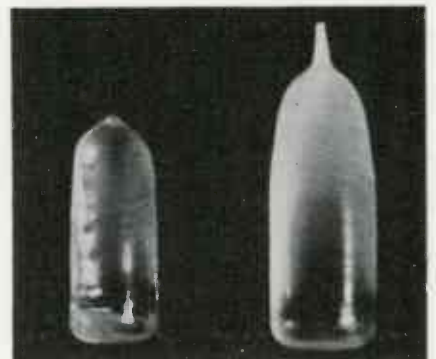

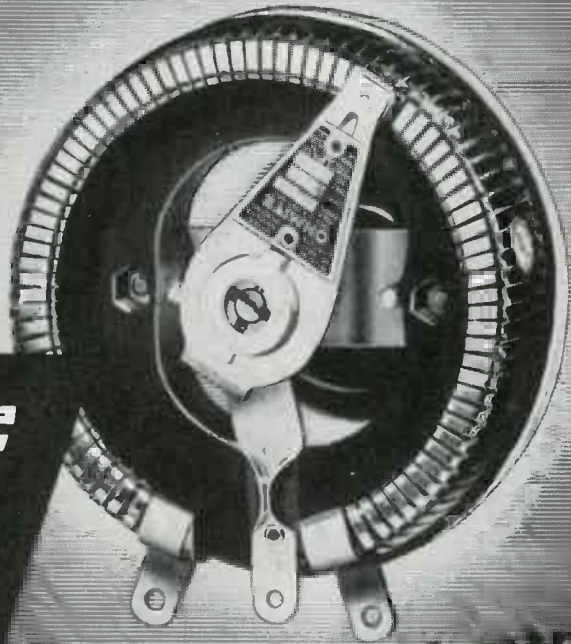
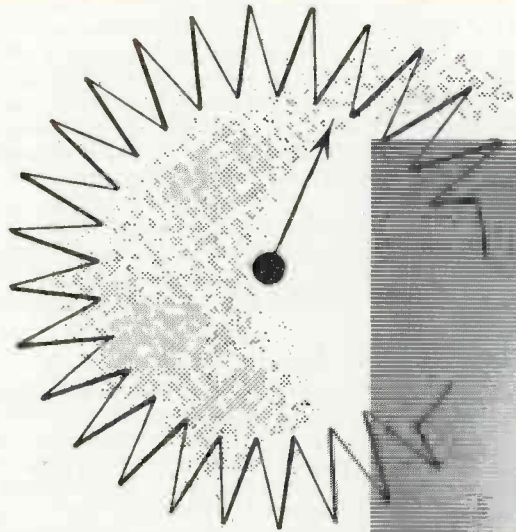

OHMITE

All-Ceramic Vitreous-Enameled

RHEOSTATS

for **PERMANENT** Smooth Control...

There is a basic difference in Ohmite rheostat design that becomes more and more apparent in actual service... a difference in smoothness of action, in long life, in trouble-free performance that means *permanently* smooth, close, electrical control. Every design feature has been time-proved under the most critical conditions, in every climate, on land, at sea and in the air. This soundness of design, plus the wide range of types and sizes, has made Ohmite Rheostats readily applicable to today's vital needs in war and industry. It also makes them ready to serve in the design of new devices to defeat the enemy and build for tomorrow's peace. Many stock types. Special units engineered for you. Approved types for Army and Navy specifications.

Send for Catalog and Engineering Manual No. 40

Write on company letterhead for this helpful 96 page guide in the selection and application of Rheostats, Resistors, Tap Switches.

OHMITE MANUFACTURING CO., 4983 FLOURNOY ST., CHICAGO, U. S. A.

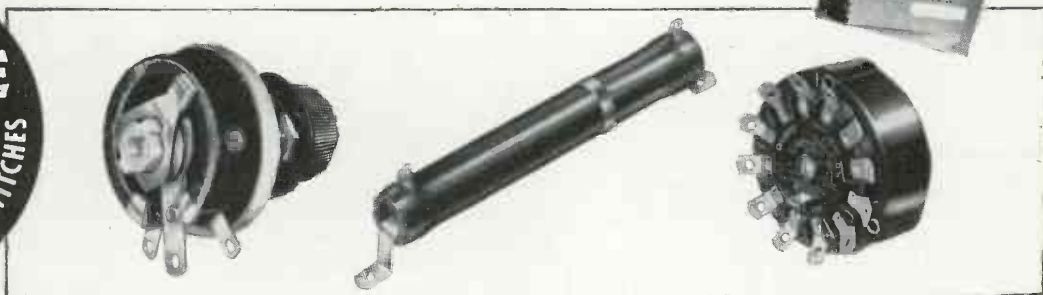

Co., a unit of Union Carbide and Carbon Corp., 30 East 42nd Street, New York. Jewels cut from these synthetic boules are used as bearings of chronometers, compasses, electrical fire-control, and aircraft instruments. It is claimed that they are successfully although still experimentally employed as insulators in gas-filled or vacuum thermionic devices and in various other instances. In the photograph, on the left, a 200-carat boule typical of present commercial production is shown. On the right is the "1943" model, one of largest yet made. It weighs about 350 carats and its total actual length is 2¾ inches.

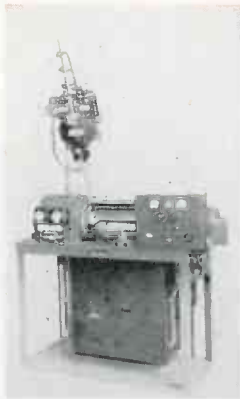

equipment is similar to that used for welding with coiled electrodes except for the electrode feed rolls and electrode guiding device. A clamp for holding any standard stick electrode is attached to the end of a feed rod upon which two feed rolls operate to maintain the proper arc voltage through automatic thyatron control. Limit switches govern the extremes of movement in either direction.

Parts are available to adapt welding heads designed for coiled electrodes for stick electrodes.

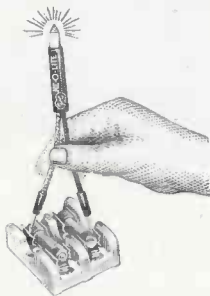

Test Lamp

A neon lamp assembly is announced by the General Cement Mfg. Co., 917-21 Taylor Ave., Rockford, Ill. It may be used to indicate polarity of dc and the ground of ac, to check blown fuses, to test electric cables, spark plugs and to serve as a radio frequency indicator. The unit glows on 60 to 500 volts ac or dc and is about 8 inches long. List price is \$1.00.

New Aircraft Relay

The B-2-A relay illustrated is one of a series of units which have been designed by Guardian Electric, 1622 West Walnut St., Chicago,

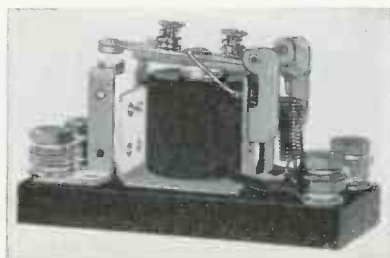

for remote control of aircraft electrical circuits. Built to U. S. Army Air Force specifications, the relay has a contact rating of 25 amperes continuous and 100 amperes surge at 24 volts dc. It has single pole, single throw, normally open contacts. Weighs 6 ounces.

It is claimed that the unit has acceleration and vibration resistance over 10 times gravity. Metal parts are heavily plated to withstand 200-hour salt spray test.

Dosage Meter

The Geophysical Instrument Company, 1315 Half Street, S.E., Washington, D. C., manufactures an electronic dosage meter that provides protection for workers using radioactive compounds. The meter indicates at all times the intensity of penetrating rays due to radium, other radio-active materials and X-rays. No attention is required, since the operation is automatic. A red light and buzzer operates when the intensity exceeds a safe value. It can also be used to aid in locating lost or misplaced radium. A Geiger-Mueller counter tube together with auxiliary vacuum-tube circuits is employed. Connections are provided for an external alarm circuit operating at 6 volts. The standard instrument is constructed for 115-volt 60-cycle operation. Units are also available for 25-cycle 220-volt operation or for direct current use. An auxiliary battery supply can be furnished in a separate unit to allow portable use.

Transformer

Thermite treated transformers intended to withstand humidity and heat are announced by the Thermador Electrical Manufacturing Co., 5119 S. Riverside Drive, Los Angeles, Cal., for use in radio sets exposed to extreme and varying weather conditions.

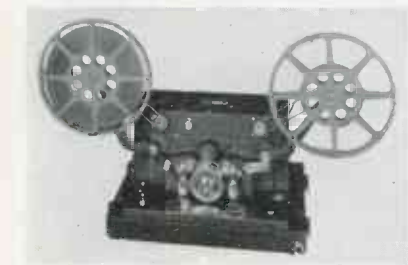
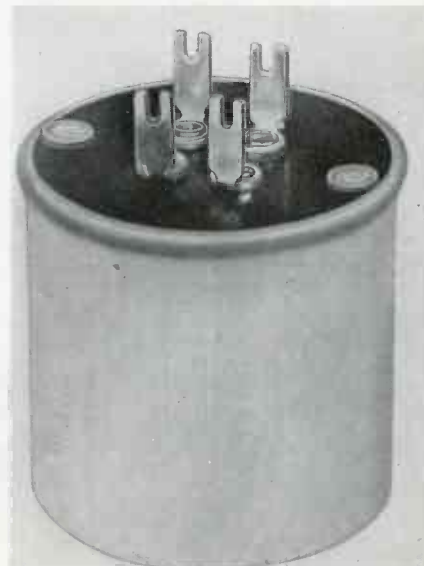

Sound-on-Film Reproducer

For studio transcription and station record libraries, the portable sound-on-film reproducer designed by Litho Equipment and Supply Co., 215 West Ohio Street, Chicago, eliminates the bugaboo of record wear, scratching and breaking. It has a capacity of continuous playing from one 2,000 foot, 5 track, 16mm. film recording, of 5 hrs.

A specially developed film-stabilizing mechanism and a powerful synchronous motor assure even sound. The selector dial permits changing to any one of the five different sound tracks even when the film is in progress. Noiseless reproduction of all types of sound tracks is possible by an optical system coupled with a noiseless source of exciter lamp supply and a special photoelectric cell.

Radio Jacks

C. D. Wood Electric Company, Inc., 826 Broadway, New York, N. Y., is now manufacturing a line of telephone and radio jacks used in radio sets and switchboards by the U. S. Government. The frame of these Woodwin jacks is of one-piece steel construction, the contacts are of silver and insulation resistance, voltage break-down and tolerances meet all requirements.

Automatic Arc Welder

Complete equipment for automatic arc welding with heavily coated electrodes in cut lengths is announced by the General Electric Company, Schenectady, N. Y. The



NOTHING TO A GREMLIN— *with dependable Utah Switches*

THOSE mischief-making, invisible little creatures, known among the RAF as Gremlins, can't stir up trouble where Utah Switches are concerned. Like other Utah-Carter parts, Utah Switches are built to give dependable performance—and have proved themselves in hundreds of electrical operations.

Compact size, highest quality and economical price are combined in Utah "Imp" push-button switches. They have the finest nickel silver or phosphorous

bronze springs with integral contacts. Springs are fully insulated in the mounting, bushing and shaft—have high grade phenolic insulation. They are available in three circuit arrangements: "Single-Make"—"Single-Break"—one "Break-Make."

Also available are Utah-Carter Rotary and Push-Button Jack switches, in long and short types. Small and compact in size, they are made to take minimum panel size. Full insulation is provided for all electrical parts. Write today for full details.

UTAH VITREOUS ENAMEL RESISTORS—from 5 to 200 watts, they are available either as fixed—tapped or adjustable. Also non-inductive types.

UTAH JACKS—long and short frame and "Imp" type jacks to meet your requirements. Special Utah jacks to meet Navy and Signal Corps specifications.

UTAH PHONE PLUGS—two or three conductor types—for practically every type of application.

UTAH TRANSFORMERS are fully guaranteed. Able to meet the requirements in choke, input, output and smaller capacity power transformers.

UTAH RADIO PRODUCTS COMPANY

General Offices and Factory

850 ORLEANS STREET

CHICAGO, ILLINOIS

NEW PATENTS ISSUED

Summaries of inventions relating to electronic uses

Note: Date application was Filed shown by (F). Date patent Issued, (I). For the reader's convenience, patents most recently issued are presented first.

FM and PHASE MODULATION

Normalizing Thermionic Oscillators—Constancy of the generated frequency against variations in tube resistance and in the resistance of the resonant circuit is increased. The apparatus consists of a series-resonant circuit connected in series with the cathode-plate alternating current circuit and tuned to the natural frequency of the inductance-capacitance elements of a parallel resonant circuit containing a resistance and also arranged in the plate-cathode circuit. Both resonant circuits are inductively coupled to two inductances, respectively, which inductances are connected in se-

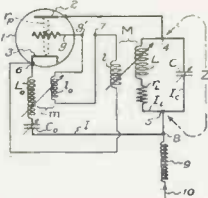

ries and provide feedback voltages for the control grid. The feedback voltage derived from the series-resonant circuit, upon amplification, equalizes the reactive voltage component of impressed voltage at the natural frequency, upon the parallel resonant circuit, relative to the cathode-plate alternating current, thereby maintaining the feedback voltage of the latter in exact phase opposition to the cathode-plate alternating current, independent of variations in tube resistance and resonant-circuit resistance. E. H. Lange, (F) June 30, 1941, (I) Dec. 15, 1942, No. 2,305,262.

FM Monitor—The modulation indicator described comprises means for accentuating or attenuating the amplitude of the carrier at two different frequencies, respectively. The thus modified frequency-modulated carrier signal deflects the beam of a cathode-ray tube in one direction, while the other deflection is controlled by the modulating signal. A pattern indicative of the frequency excursions of the frequency-modulated carrier signal is obtained on the screen of the tube. J. C. Ferguson and P. J. Herbst, Farnsworth Television and Radio Corp., (F) Sept. 16, 1940, (I) Dec. 8, 1942, No. 2,304,635.

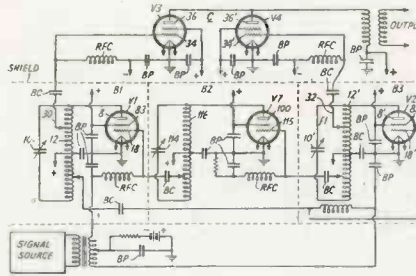

Frequency Modulator—Three oscillators, each comprising a tube and a circuit tuned to a different frequency and coupled to the tube electrodes, are connected to form a ring-connected oscillator by coupling corresponding electrodes of each tube to a point on the tuned circuit of another tube. The oscillator operates substantially at a single frequency. A circuit is provided to differentially modulate the impedance of two tubes in accordance with signals. G. L. Usselman, RCA, (F) June 18, 1940, (I) Dec. 8, 1942, No. 2,304,388.

Receiving System—A high-frequency receiver contains three channels passing the carrier frequency and one group of side-band frequencies, respectively. The energy of the side-band channels is combined with a portion of the energy in the carrier channel, each rectified separately and then com-

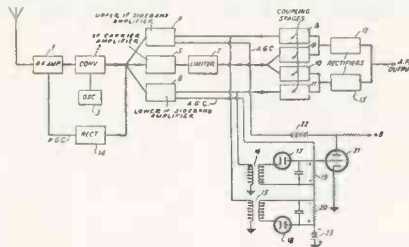

combined. A portion of the energy of each of the side band channels is rectified and the rectified energies are compared. Means responsive to the comparison are provided for discriminating against the energy in one of said channels. De Witt Rugg Goddard, RCA, (F) Sept. 12, 1941, (I) Dec. 1, 1942, No. 2,303,542.

Modulation System—A frequency stabilized oscillation and a phase-modulated oscillation are applied to the input of a transmission line for multiplying the phase-shift of the modulated oscillation by the number of wavelengths of the line.

Means for combining these oscillations are connected to the line to obtain beat frequency currents which are applied to a load circuit. John Evans, RCA, (F) May 27, 1941, (I) Dec. 1, 1942, No. 2,303,444.

Phase Modulation System—The carrier frequency is fed to the grids of three electron tubes. The output of one of the tubes is applied to a circuit tuned to the carrier frequency and the output of the other two tubes is connected in push-pull to another circuit also tuned to the carrier frequency, the circuits being reactively coupled. Modulating potentials are applied to the three grids, the modulating potentials

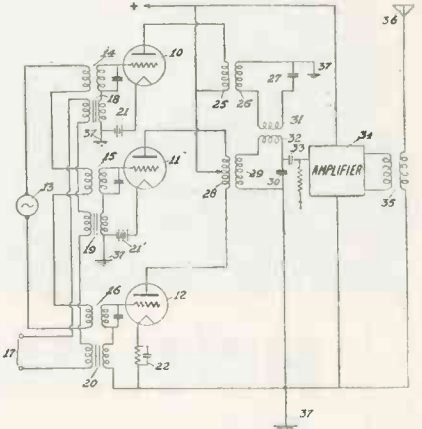

impressed upon the grids of the push-pull connected tubes being of opposite polarity. The steady bias of each of the push-pull connected tubes is below and above, respectively, the steady bias of the third tube. The utilization circuit is energized from at least one of the resonant circuits. Jozef Plebanski, Radio Patents Corp., (F) June 20, 1940, (I) Dec. 1, 1942, No. 2,303,863.

TELEVISION

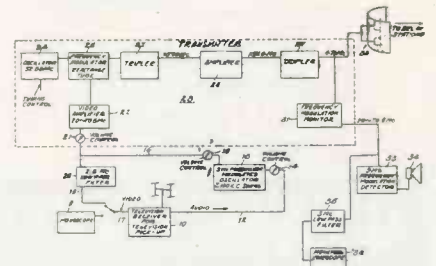

Multiplex System—The instantaneous frequency of a carrier is modulated by a signal wave which

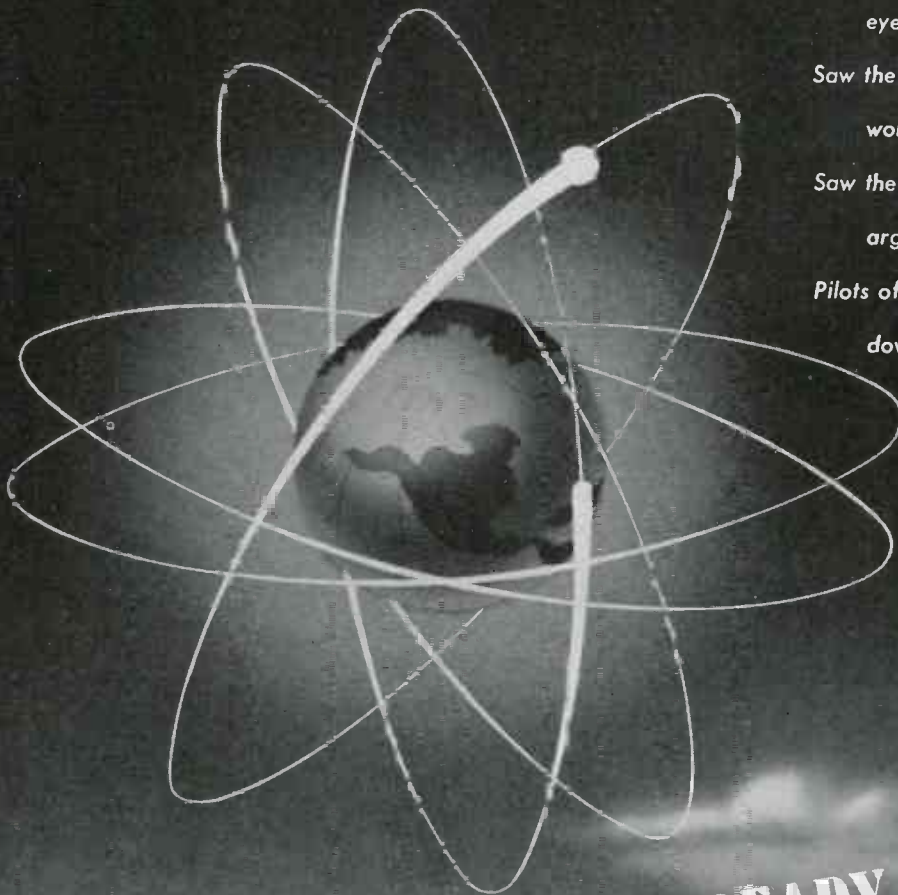

*"For I dipt into the future, far as human
eye could see,
Saw the vision of the world, and all the
wonder that would be;
Saw the heavens fill with commerce,
argosies of magic sails,
Pilots of the purple twilight, dropping
down with costly bales."*

ALREADY IN SIGHT

Tennyson's prophetic vision, more than half a century ago, is just over tomorrow's horizon. Far beyond the reaches of his poetic imagination are the marvels planned for the post-war world by aviation and radio engineers.

The necessities of war . . . our quickened mental and physical pace . . . even war's shortages and restrictions—all are responsible for a forward surge of scientific discovery that gives promise of being without parallel in our Nation's history.

Among contributors to the bright, new world, the

Electronic Industry is certain to be one of the most spectacular.

Proud of its name and place in this great industry . . . sensible to the challenge . . . IRC stands ready!

★ ★ ★

Although practically 100% of our business today is in the high-priority, war-essential category, our thinking is unrestricted. We will be happy to work with you on "futures." May we help to develop your post-war ideas and plans?

Preferred for Performance **IRC** *Fixed & Variable Resistors*

INTERNATIONAL RESISTANCE COMPANY

425 N. BROAD STREET • PHILADELPHIA

is unsymmetrical about a zero axis to obtain a spectrum of frequencies which is unsymmetrical about the unmodulated frequency of the carrier. The spectrum of frequencies thus obtained is filtered to remove at least a portion thereof on one side of the unmodulated frequency of the carrier which is radiated. Upon reception, a wave representative of the signal wave is derived from the received carrier. B. Trevor, RCA, (F) July 31, 1940, (I) Dec. 15, 1942, No. 2,304,969.

Cathode-Ray Signal-Generator—

A cathode-ray tube provided with a photosensitive target electrode is used for image-transmission. The velocity of the electron beam is sufficiently low at the target electrode to provide a secondary-emission ratio of less than unity and for returning free electrons from the vicinity of the target. Scanning of the target in two directions at right angles to one another is accomplished by two magnets. The number of electrons returning from

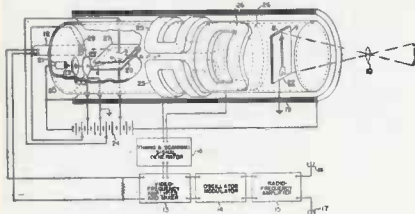

the target is determined by its charge at the area scanned, and they are travelling back substantially the same path through the magnets taken by the primary beam. A pair of beam-shifting plates is arranged near the electron emitting electrode. Their distance from one another is small relative to the scanning deflections, and a steady unidirectional potential is applied to them which directs the returning electron beam to the collector. R. C. Hergenrother, Hazeltine Corp., (F) Jan. 19, 1940, (I) Dec. 8, 1942, No. 2,304,091.

SEISMIC WAVE RECORDING

Expander for Electrical Seismographs—Electrical signals corresponding to the seismic waves are generated, which signals are of a plurality of definite frequencies. Upon amplification, the electrical signals are recorded in coordination with time. The improvement consists in diverting a portion of the signals passing through the amplifier, suppressing signals of undesirable frequencies from the diverted portion by means of a filter, rectifying the signal voltages of the selected frequency and applying this rectified voltage to the control grid of at least one of the amplifier tubes

to control the gain in amplification imparted to all signals passing through that tube independent of their frequency. M. D. McCarty, Socomy-Vacuum Oil Co., Inc., (F) Feb. 5, 1941, (I) Dec. 15, 1942, No. 2,305,543.

Seismic Wave Amplifier—Automatic amplitude control is effected by applying part of the control voltage to a gain control element having a negative curvature characteristic over a substantial range, another part being applied to a gain control element having a positive curvature characteristic. The gain is affected in the same direction by both these controls. Thus, a stable, automatic amplitude control is attained over a wide range of incoming signal strength. Herbert Hoover, Jr., Consolidated Engineering Corp., (F) July 26, 1939, (I) Dec. 1, 1942, No. 2,303,357.

MISCELLANEOUS

Broadcasting System—A source of intelligence signals including a preselected signal is connected to a plurality of intelligence signal transmitting stations spaced from the source and including broadcasting means. The connecting circuit is such that normally the intelligence signals are effectively applied to the broadcasting means. Upon receipt of the preselected signal, however, the source is disconnected for a certain time interval during which other signals are applied to the broadcasting means. L. C. Roberts, (F) Aug. 28, 1941, (I) Dec. 15, 1942, No. 2,305,496.

Translating Circuit—A source of waves having steep wave fronts is connected between control grid and cathode of a tube through a load impedance upon which the waves are reproduced. Plate voltage from the tube is supplied to the load impedance to neutralize the potential supplied to the load impedance through inherent capacity between control grid and cathode. E. H. B. Bartelink, General Electric Co., (F) Oct. 13, 1941, (I) Dec. 15, 1942, No. 2,305,403.

Secondary Emission—A pair of secondary electron emitting electrodes is interposed in the space between control grid and plate of an hf amplifier tube. An output impedance is connected between plate

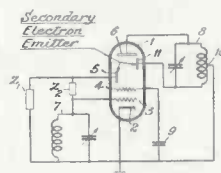

and one of the secondary electron emitting electrodes, the other one being coupled to a composite impedance the two portions of which are connected to grid and cathode, respectively. The portions of the composite impedance are so dimensioned and the current supplied to the control grid through the composite impedance is of such phase that the effective input impedance of the circuit and the input capacity of the tube are reduced. M. J. O. Strutt and A. van der Ziel, Alien Property Custodian, (F) March 29, 1941, (I) Dec. 15, 1942, No. 2,305,395.

Tuned Amplifier—The anti-resonant input circuit of an amplifier tube is tuned to an operating carrier frequency. A resistive impedance connects the cathode to a point of the input circuit having a potential intermediate the potentials of the high and low potential sides of the input. Between impedance and low potential side of the

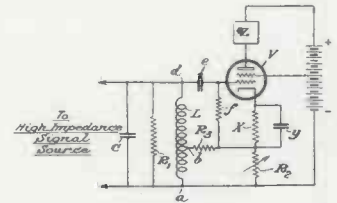

input is arranged a variable unby-passed resistor which is in the space current path of the tube. Adjustment of the resistor simultaneously alters in opposite senses the impedance of the input circuit and the rate of change of plate current with respect to voltage across the input circuit. E. L. C. White and W. Bull, Electric and Musical Ind., Ltd., (F) July 2, 1941, (I) Dec. 15, 1942, No. 2,304,978.

Automatic Tuning—The tuning means of a circuit with broad selectivity curve, operated by power actuated means and responsive to the plate current of an rf amplifying tube, stops when a carrier signal is closely tuned in. During tuning, the plate current controls a circuit effecting an increase in the selectivity of the tuned circuit. E. F. Andrews, (F) Feb. 3, 1941, (I) Dec. 15, 1942, No. 2,304,871.

Tuning Impedance—Inductive transmission line segments are used for coupling between antenna and amplifier, amplifier and mixer, and mixer and oscillator of a preselector circuit. The grounded ends of each segment are conductively connected, and their other ends are coupled by variable condensers. George E. Pray, (F) Aug. 2, 1941, (I) Dec. 1, 1942, No. 2,303,388.



Wire Wound Radiohms by Centralab

Available in single or tandem type . . . with or without switch . . . for use as a potentiometer or rheostat . . . in resistance values up to 10,000 ohms.

Linear taper only . . . rated conservatively at 3 watts . . . temperature rise of 100 ohm unit is 28° C. at 3 watts, 40° C. at 4 watts with load carried over total resistor.

Total rotation 300°. Switch type requires 40° for switch throw.

Available to Your Specifications

CENTRALAB: DIV. OF GLOBE-UNION, INC., MILWAUKEE, WIS.

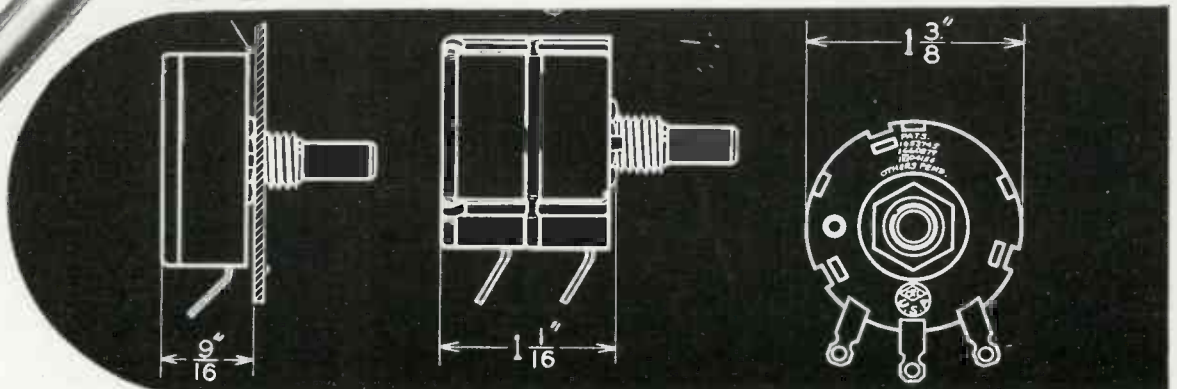
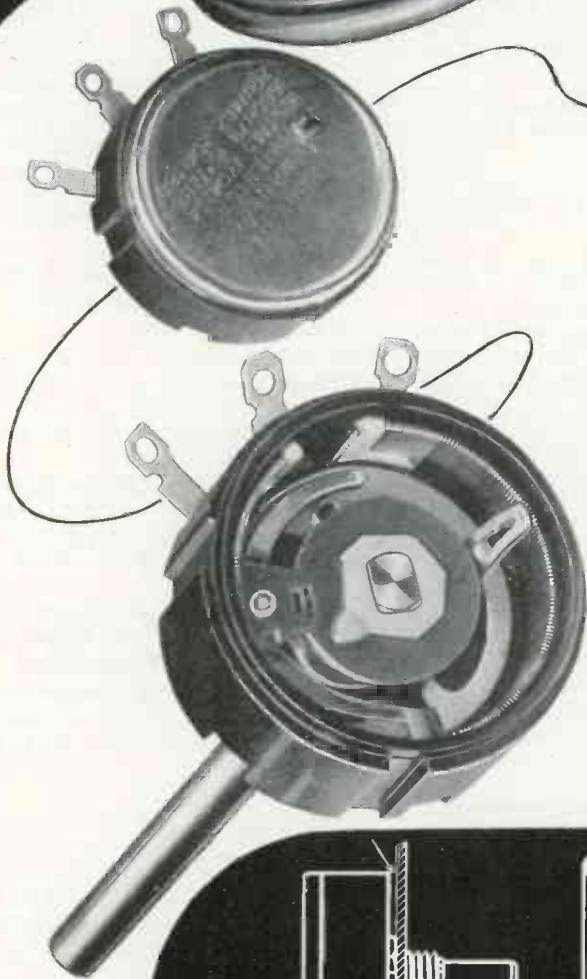

ASSOCIATION NEWS

AIEE "Electronics in War-time" Conference Jan. 27

Under the sponsorship of the new AIEE Technical Committee on Electronics, of which Dr. S. B. Ingram, Bell Telephone Laboratories, is chairman, a session on "How to Get the Most Out of Electronic Tubes in Wartime" will be held at the Engineering Societies' Building, 29 West 39th street, New York City, Wednesday, Jan. 27, at 3 p.m.

There will be informal discussions on methods of operating electronic devices to improve their life and increase their usefulness under present war conditions. Mercury-arc rectifiers, electronic tubes for industrial uses, and broadcast transmitting tubes will be considered. The question of adequate ratings and practices to obtain maximum utility will be discussed.

Among those scheduled to initiate the discussion on electronics in wartime, will be C. C. Herskind, General Electric Co.; D. W. Jenks, General Electric Co.; E. E. Spitzer, RCA Mfg. Co., and G. H. Rockwood, Bell Telephone Laboratories.

General discussion invited

Besides these speakers, it is hoped to obtain a wide participation in the discussion of wartime electronics, particularly by those who are users of electronic devices and have had practical experience with electronic equipment. Since

Dr. Edwin H. Armstrong who receives AIEE Edison Medal, Jan. 27



the proceedings of the conference will not be published, it is expected that those taking part will speak freely.

At an 8:15 evening session of the AIEE, that same day, the Edison Medal for 1942 will be awarded to Dr. Edwin H. Armstrong, professor of electrical engineering at Columbia University, "for distinguished contributions to the art of electric communication, notably the regenerative circuit, the superhetrodyne, and frequency modulation."

IRE War Conference at NY, Jan. 28

The IRE Winter Conference will be held in the Engineering Societies Building, 29 W. 39th St., New York, Thursday, Jan. 28, in cooperation with the National Technical Meeting of the AIEE. In other cities, many sections of IRE will hold local meetings about the same time.

At the 10 a.m. morning session in New York the following papers will be presented:

"Transmission-Line Charts," R. S. Julian, Bell Telephone Laboratories, Whippany, N. J.

"Polydirectional Microphones," H. F. Olson, RCA Mfg. Co., Camden, N. J.

"Phosphors and the Periodic System of the Elements," by H. W. Levenenz, RCA Mfg. Co., Camden, N. J.

"Radio-Frequency Operated High-Voltage Supplies for Cathode-Ray Tubes," by O. H. Schade, RCA Mfg. Co., Harrison, N. J.

At 2:30 p.m. the Institute's annual meeting will open with addresses by Arthur Van Dyck, retiring president, and Dr. L. P. Wheeler, incoming president. The Institute Medal of Honor will be presented to William Wilson for achievements in electronics. Fellowships will be conferred on Andrew Alford, I. S. Coggeshall, Capt. J. B. Dow, USN, L. A. DuBridge, P. C. Goldmark, D. E. Harnett, D. D. Israel, A. G. Jensen, Col. G. F. Metcalf, and Irving Wolff.

War Production

"Radio Engineering in War" will be the theme of special addresses to follow. Scheduled to take part are Lloyd Espenschied, Rear Admiral S. C. Hooper, Ray C. Ellis, director Radio Division, WPB, and other government officials.

In the evening at 8:30, Dr. G. C. Southworth of Bell Laboratories will address a joint AIEE-IRE meeting on "Ultra-High Frequencies."

At 10:30 p.m. EWT, over a coast-to-coast CBS hook-up, President Van Dyck and President-elect

Wheeler will greet radio men all over the nation (including IRE sections which are meeting that evening), after which an official of the Board of War Communications will complete the broadcast period from the Washington banquet at the Willard Hotel.

Conventions and Meetings Ahead

American Welding Society (Miss M. M. Kelly, 29 West 39th Street, New York), Jan. 12, Engineering Societies' Building, Room 501, New York.

American Association for Advancement of Science (27 Washington Sq., New York) and **American Physical Society**, Jan. 22 and 23. Columbia Univ., New York.

Radio Club of America (11 West 42nd Street, New York), Jan. 14, 309 Havemeyer Hall, Columbia University, New York.

AIEE (H. H. Henline, 29 West 39th Street, New York), National Technical Meeting, Jan. 25-29, 1943, Engineering Societies' Building, New York; District Technical Meeting, April 8-9, Pittsfield.

Electrochemical Society (Colin G. Fink, Columbia University, 3000 Broadway, New York), April 7-10, Hotel Roosevelt, Pittsburgh, Pa.

American Chemical Society (Alden H. Emery, 1155 Sixteenth Street, N. W., Washington), April 12-16, Indianapolis, Ind.

National Electrical Manufacturers Association (W. J. Donald, 155 East 44th Street, New York), Spring Meeting, April 19-23, Palmer House, Chicago.

American Society of Mechanical Engineers (Ernest Hartford, 29 West 39th Street, New York), Spring Meeting, April 26-28, Davenport, Ia.

American Institute of Chemical Engineers (50 East 41st Street, New York), May 10-11, New York.

Acoustical Society of America (Wallace Waterfall, 120 South LaSalle Street, Chicago), May 1943, New York.

NAB Standards for Recording

Sidney Gould, president of Gould-Moody Company, 395 Broadway, New York, manufacturers of Black Seal glass-base discs, has just published an excellent help for the radio engineer—"Technical Standards and Good Engineering Practices." This folder, printed on tough, durable paper, able to handle plenty of punishment, done in two colors, contains the 14 pertinent facts as established by the National Association of Broadcasters.

LOOKING INTO THE FUTURE WITH ELECTRONICS



NEVER before has an industry held in its hands a science with so many potentialities as Electronics. For us in the industry, this is a challenge and a tremendous opportunity. Manufacturing, commerce, communications, agriculture, medicine and education — all will make wide use of electronic devices.

But electronics is also a responsibility — the power to remodel a world. We who are engaged in its development must guide that power with care and wisdom.

As an organization founded upon electronic research, we at Farnsworth recognize that responsibility — and shall always consider it a keystone of our policies.

FARNSWORTH research has always been concentrated in the fields of television, radio and sound reproduction.

Naturally, then, our role in war is the manufacture of communications equipment. With all the forces at our disposal — our large production facilities, our highly skilled personnel, our 15 years of experience — we are producing military radio equipment and other devices for the armed forces.

We are learning much. Tomorrow's Farnsworth television and radio transmitters and receivers will be better than yesterday's. Farnsworth aircraft radio equipment has already made enormous advances. Our phonograph-radios will incorporate improvements. Even the superb Capehart will be a finer instrument. As electronics progresses — so will Farnsworth, always.

Ed Michaelson
President

Farnsworth TELEVISION & RADIO CORPORATION

Manufacturers of Radio and Television Transmitters and Receivers; Aircraft Radio Equipment; the Farnsworth Dissector Tube; the Capehart, the Capehart-Panamuse, and the Farnsworth Phonograph-Radios.

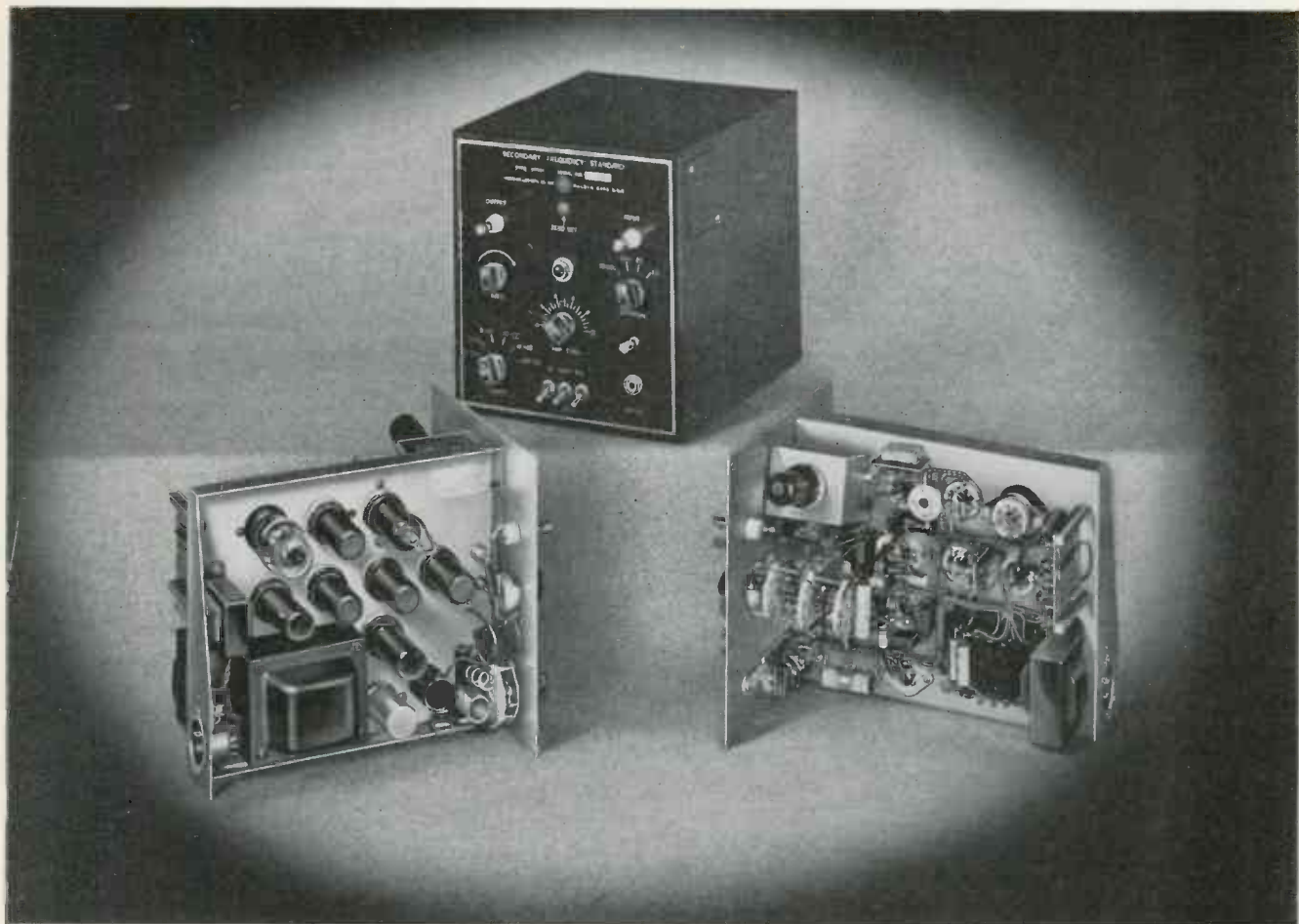

“Designed for Application”

**THE
90505 Secondary Frequency Standard**

A Precision Frequency Standard for both laboratory and production uses. Designed around the GE G-18 and G18-A crystal, having a frequency temperature coefficient of less than 1 cycle/Mc/C°. The crystal is sealed in Helium in a standard metal tube envelope. Adjustable output provided at intervals of 10, 25, 100, and 1000 KC with magnitude useful to 50 MC. Harmonic amplifier with tuned plate circuit and panel range switch. 300 cycle modulator, with panel control switch. Panel plate supply control switch. In addition to Oscillators, Multi-vibrators, Modulators and Amplifiers, a

built-in Detector with 'phone jack and gain control on the panel is incorporated. Easily adjusted to WWV. Self-contained AC power supply with VR 150-30 voltage regulator. Used in quantity by Signal Corps, Navy, FCC, British and all large government prime contractors such as GE, RCA, Western Electric, Sperry, Westinghouse, etc. Cabinet size 9" x 9 $\frac{5}{8}$ " x 10 $\frac{1}{2}$ ", weight 20 lbs. Compact, dependable, stable, trouble-free. Price complete with GE crystal and tubes \$135 net, f.o.b., Malden, for 115 V. 60 cycle model. Available for the duration, of course, only on proper priority.

JAMES MILLEN

MAIN OFFICE



MFG. CO., INC.

AND FACTORY

MALDEN, MASSACHUSETTS, U.S.A.

LATEST

NEWS FROM WASHINGTON

Concerning the Electronic Industries



1943 OUTLOOK — Despite difficulty of predictions in present Global War, 1943 outlook for the electronic industries, as viewed by highly authoritative Government sources, is that rate of production of past two months will constitute 1943 yardstick of demands by the armed services. Industry will be called upon for greater concentration and production upon radar apparatus and equipment, than upon radio-communications items, according to present trends. Some civilian production will be continued — although manufacturing for strictly war needs will remain around 90 per cent of the radio-electronic production picture.

WPB CIVILIAN RADIO — Tubes for replacement, especially for broadcasting stations and home receiving sets (and to smaller extent for other radio services) are being allocated for manufacture for the 1943 first quarter. Production of other components of transmitting and receiving apparatus — broadcasting, radio-communications, aviation, police, etc. — also is being planned. (Incidentally, John Q. Public, who has a burned-out tube in his home set, now has to turn back his old tube for a new one, just as for toothpaste or shaving cream.) Frank H. McIntosh, Chief of the Civilian Radio Branch, has just been made Assistant Director of the Division, under Director Ray Ellis.

RADIOS FOR LATIN-AMERICA — Assembly of a number of radio receivers and transmitters for export to Latin America and possibly to friendly nations in other parts of the world will soon be authorized by the WPB. The program as to the quantity of this export radio equipment has not yet been approved in detail, but sanction of its principle represents a victory for BEW and CIAA.

ELECTRONIC INDUSTRY BRINGS HOME BACON — Both WPB Chairman Donald Nelson and Secretary of War Stimson have pinned orchids on the radio and electronic industry. Nelson reported that for November production of radio and detection equipment continued to increase — the industry produced equipment valued at \$160,000,000, a gain of 15% over the \$135,000,000 delivered to the armed services in October. At the end of that month the total backlog on prime contracts amounted to \$2,967,167,000. Secretary Stimson brought out that the Signal Corps' Supply Services, directed by Major General Roger B. Colton, was in the forefront of the Army's Services of Supply, with a November gain of 30.5% over the preceding month. November score for the Signal Corps in deliveries of equipment as contrasted with January, 1942, — the first full production month after Pearl Harbor — was 1328% increase.

POOLING OF IDEAS, INVENTIONS, PROCESSES — Flexibility of production under CMP is the goal of the WPB Radio & Radar Division and armed services during 1943. Key to flexibility in the electronic industry will be exchange and pooling of ideas, inventions, materials and processes — as the highway to the haven of steady, efficient production. Through a record of inventories, raw materials, fabricated materials and finished products, can be "mentally stock piled" so, that if one manufacturer is out of a strategic raw material another who has an abundant supply can rush a sufficient quantity to keep production lines moving.

CENTRALIZED MANUFACTURE — In the case of certain small items such as meter pointers, springs, coils, etc., WPB projects that a large quantity be manufactured for distribution to all equipment manufacturers who would all pool their orders with makers of such items. Washington authorities also are now trying to standardize scheduling and production to avoid wasteful manufacturing processes. Further standardization between Army and Navy equipment, will enable each service to utilize components, parts and spare apparatus in emergencies.

PATENT EXCHANGE — An untrammelled exchange of inventions, ideas and production methods and processes is being advocated by WPB. This should occur, particularly, within industries making components and parts, as it will bring about the most efficient process, it is felt. There will be savings of materials and manhours. Inspections by the government agencies, too, must be made more orderly and reduced especially to avoid damaging of equipment by overloading during tests.

ANEPA ON JOB — The Army-Navy Electronics Production Agency — a team of Army and Navy officers and a group of civilians handpicked from industry because of experience as engineers, radio technicians and industrialists — has distributed posters to the electronic industry with the slogan — "He (the soldier, sailor and marine) Needs What You Make, Now". The ANEPA is continuously remedying, speedily and effectively, bottlenecks of materials, labor and methods. ANEPA Chief Production Engineer George W. Parkin, formerly production manager of one of the largest automobile companies, told ELECTRONIC INDUSTRIES that the electronics contractors collectively did an admirable job in 1942 and both ANEPA is sure of their continued cooperation in 1943.

MISCELLANY — Army Signal Corps, due to dearth of experienced civilians, is training its own Supply officers at two schools in Philadelphia and Lexington, Ky. FCC Chairman James Lawrence Fly wants the electronic industry to set up a committee to discuss and plan post-war programs with the Commission www.americanradiohistory.com



Are you, like so many other professional radiomen, so wrapped up in your present routine work, that you are losing sight of where you will be "tomorrow"?

Jobs that provide security—jobs that will mean something long after this war is over—must be won and held on ability! Now is the time for you to make your present job an investment in a secure future. Many ambitious radiomen have been set on the right course with the help of CREI advanced technical training. This practical course plus the personalized home-study instruction provide a proven formula for more rapid advancement.

THINK THIS OVER—Records show: • CREI training pays dividends in the form of job security and the ability to earn more money • More than 8000 radiomen have taken this practical course of training • CREI men are in more than 400 broadcasting stations • Employers are increasingly calling upon CREI graduates to fill the important engineering positions.

Why not investigate what CREI spare-time training in Practical Radio Engineering can do for you? You have a jump on the other fellow because your radio experience is a valuable asset, if supplemented with this modern training. It's worth taking time now to find out how CREI offers you a planned program which will hasten your advancement in radio.

• Write for free 32-page booklet

If you have had professional radio experience and want to make more money—let us prove to you we have something you need to qualify for a better radio job. To help us intelligently answer your inquiry—please state briefly your background of experience, education and present position.



CREI Students, Graduates — ATTENTION!
The CREI Placement Bureau is flooded with requests for radiomen. Employers in all branches of radio want trained men. Your Government wants every man to perform his job, or be placed in a job, that will allow him to work at maximum productivity. If you are or will be in need of re-employment write your CREI Placement Bureau.

CAPITOL RADIO ENGINEERING INSTITUTE
 Home Study Courses in Practical Radio Engineering for Professional Self-Improvement.
 Dept. EI, 3224 — 16th Street, N.W.
 WASHINGTON, D. C.

Contractors to the U.S. Signal Corps—U.S. Coast Guard
 Producers of Well-trained Technical Radiomen for Industry

New Tubes

The RCA Manufacturing Company makes available the following new tube types for use in connection with WPB rated orders.

6A5G—RF Amplifier Pentode Sharp Cut-off (Miniature Type)
 Heater Voltage (A.C. or D.C.) 6.3 Volts
 Heater Current 0.3 Amp.
 Direct Interelectrode Capacitances (Approx.):
 Grid to plate, C_{g1p} 0.025 max. mmf.
 Input, C_{g1} (h+k & g₃ & internal shield—e₂) 6.5 mmf.
 Output, C_p (h+k & g₃ & internal shield—e₂) 1.8 mmf.

AMPLIFIER TYPICAL OPERATION AND CHARACTERISTICS—
 Class A₁ Amplifier:

Plate Voltage	100	125	250
Screen Voltage (Grid No. 2)	100	125	150
Cathode-Bias Resistor	100	100	200

Filament Voltage (ac) 5.0 Volts
 Filament Current 2.0 Amperes
 Peak Inverse Voltage (No-Load Conditions) 2800 max. Volts
 Peak Plate Current Per Plate 650 max. Milliampers

With Condenser-Input Filter:
 A-C Plate Voltage per Plate (RMS) {Full Load 700
 {No Load 750
 Total Effective Plate-Supply Impedance per Plate 125
 D-C Output Current 250 max. Milliampers

With Choke-Input Filter:
 A-C Plate Voltage per Plate (RMS) {Full Load 750
 {No Load 850
 Input-Choke Inductance 5 min. Henries
 D-C Output Current 250 max. Milliampers

Plate Resistance (Approx.)	0.3	0.5	0.8
Transconductance	4750	5100	5000
Plate Current	5.5	7.2	7
Screen Current	1.6	2.1	2

6J6—Twin Triode (Miniature Type)
 The 6J6 is a heater-cathode type of miniature tube having two grids and two plates with a common cathode. With a push-pull arrangement for the grids and with the plates in parallel, the 6J6 is particularly applicable as a mixer at frequencies as high as 600 megacycles. It is also useful as an oscillator.

Heater Voltage (A.C. or D.C.) 6.3 Volts
 Heater Current 0.45 Amp.
 Direct Interelectrode Capacitances—
 Each Unit (Approx.)
 Grid to Plate, C_{gp} 1.6 mmf.
 Grid to Cathode, C_g (h+k) 2.2 mmf.
 Plate to Cathode, C_p (h+k) 0.4 mmf.

R-F POWER AMPLIFIER AND OSCILLATOR—
 CLASS C TELEGRAPHY

TYPICAL OPERATION AT MODERATE FREQUENCIES
 IN PUSH-PULL—Both Units:

(Key-down conditions per tube without modulation)
 D-C Plate Voltage 150 Volts
 D-C Grid Voltage 10 Volts
 From a fixed supply of 10 Volts
 From a grid resistor of 625 Ohms
 From a cathode resistor of 220 Ohms
 D-C Plate Current 30 Milliampers
 D-C Grid Current (Approx.) 16 Milliampers
 Driving Power (Approx.) 0.35 Watt
 Power Output (Approx.) 3.5 Watts

2AP1—High-Vacuum Cathode Ray Tube
 The 2AP1 is similar to type 902 except that it has separate leads to all deflecting electrodes and the cathode, employs a magnal 11-pin base, and can be operated with higher anode voltages.
1C21—Gas-Triode (Ionic-Cathode Glow-Discharge Type)
 The 1C21 is an ionic-cathode, glow-discharge triode, designed for use primarily as a relay tube. The 1C21 may also be used as a voltage regulator, or as a relaxation oscillator.

CHARACTERISTICS

Peak Anode Breakdown Voltage (Grid tied to cathode)	180 min. Volts
Peak Positive Grid Breakdown Voltage	166 min. Volts
	180 max. Volts
D-C Anode Extinction Voltage	73 approx. Volts
A-C Anode Extinction Voltage (Rms—60 cycles)	115 approx. Volts

Grid Current (For transition of discharge to anode at 100 volts peak)	25 av. Microamp.
Anode Voltage-Drop	150 max. Microamp.
Grid Voltage-Drop	73 approx. Volts
	55 approx. Volts

MAXIMUM RATINGS

Maximum Ratings Are Design-Center Values	
Peak Cathode Current	100 max. Milliamp.
D-C Cathode Current	25 max. Milliamp.
Typical Operation as Relay Tube:	
D-C Anode-Supply Voltage	125-145 Volts
Peak Positive Grid-Bias Voltage	66 max. Volts
Peak Grid-Signal Voltage	40 min. Volts
Sum of Grid-Bias and Grid-Signal Voltages (Peak)	100 min. Volts
D-C Grid Current	100 Microamp.

5R4-GY—Full-Wave High-Vacuum Rectifier
 The 5R4-GY is a coated-filament type of full-wave, high-vacuum rectifier, having a maximum peak plate current rating of 650 milliamperes and a maximum peak inverse voltage rating of 2300 volts.

Peak Inverse Voltage (No-Load Conditions)	2800 max. Volts
Peak Plate Current Per Plate	650 max. Milliampers
With Condenser-Input Filter:	
A-C Plate Voltage per Plate (RMS) {Full Load 700 {No Load 750	900 Volts 1000 Volts
Total Effective Plate-Supply Impedance per Plate	125 Ohms
D-C Output Current	250 max. Milliampers
With Choke-Input Filter:	
A-C Plate Voltage per Plate (RMS) {Full Load 750 {No Load 850	950 Volts 1000 Volts
Input-Choke Inductance	5 min. Henries
D-C Output Current	250 max. Milliampers

934—Vacuum Phototube
 The 934 is a small high-vacuum phototube intended primarily for use in sound and facsimile equipment but it is also suitable for light-operated relays and light-measuring equipment. Its S-4 photosurface has exceptionally high response to blue and blue-green radiation and a negligible response to red radiation.

MAXIMUM RATINGS

Anode-Supply Voltage (D.C. or Peak A.C.)	250 max. Volts
Anode Current	10 max. Microamp.
Ambient Temperature	50 max. degrees C.
Sensitivity	30 Microamp./lumen
DC load resistance for 250 volt anode supply	1 min. Megohm

935—Vacuum Phototube (Ultraviolet-Sensitive Type)

The 935 is a high vacuum phototube possessing high sensitivity to radiant energy rich in blue and near ultraviolet and will respond in the region down to about 2000 Å. The 935 is particularly suited for use in measuring ultraviolet absorption of gases and liquids.

MAXIMUM RATINGS

Anode-Supply Voltage (DC or Peak A.C.)	250 max. Volts
Anode Current	20 max. Microamp.
Ambient Temperature	50 max. degrees C.
Sensitivity	30 Microamp./lumen
DC load resistance for 250 volt anode supply	1 min. Megohm

Sarnoff Visions "Thermal Radio"

"The application of radio frequency heating to speed industrial processes and at the same time increase their efficiency, is rapidly coming to the fore," explained Col. David Sarnoff, president RCA, in a 1943 prediction.

"Radio waves may now be used to heat, dry, glue, stitch, anneal, weld, rivet, and even to deactivate enzymes. This new field is known as thermal radio. It can laminate

ANNOUNCING...

the first complete

ELECTRONIC ENGINEERING DIRECTORY

in the March Issue of

**ELECTRONIC
INDUSTRIES**

For the first time in the radio-electronic field, Caldwell-Clements, Inc., will publish a **DOUBLE-INDEXED** engineering directory, listing every company that makes materials, parts or finished products for the radio-electronic field.

A complete *alphabetical* index of manufacturers will be cross-indexed with a product directory where all manufacturers will be again listed under their product classifications.

This double index is an exclusive feature, never before published in this industry.

This greater service to both reader and advertiser is another reason why your products should be advertised completely in the March Engineering Directory.

Because reservations are coming in fast, we suggest that interested manufacturers write at once for further details.

Special note—if you have not already filled out and returned your editorial questionnaire, from which your listings in the directory will be compiled, we urge you to do so at once and thus assure complete, accurate listing of your company.

ELECTRONIC INDUSTRIES

480 LEXINGTON AVE., NEW YORK • Telephone, PLaza 3-1340
201 NORTH WELLS STREET, CHICAGO • Tel. RANdolph 9225

WAR BOND PAYROLL SAVINGS ROLL OF HONOR

The eyes of all America are upon the United States Treasury Roll of Honor appearing in the "Payroll Savings News." For copy write War Savings Staff, Treasury Department, Washington, D. C.

Firms Who Can Inspire to More Employees Whose Workers Are Investing at Least 10 Percent of Their Gross Payroll in War Savings Bonds Through the Payroll Savings Plan.

State	Name of Company	Percent	Name of Company	Percent	Name of Company	Percent	Name of Company	Percent
ALABAMA	ALABAMA	...	ALABAMA	...	ALABAMA	...
ALASKA	ALASKA	...	ALASKA	...	ALASKA	...
ARIZONA	ARIZONA	...	ARIZONA	...	ARIZONA	...
ARKANSAS	ARKANSAS	...	ARKANSAS	...	ARKANSAS	...
CALIFORNIA	CALIFORNIA	...	CALIFORNIA	...	CALIFORNIA	...
CONNECTICUT	CONNECTICUT	...	CONNECTICUT	...	CONNECTICUT	...
DELAWARE	DELAWARE	...	DELAWARE	...	DELAWARE	...
FLORIDA	FLORIDA	...	FLORIDA	...	FLORIDA	...
GEORGIA	GEORGIA	...	GEORGIA	...	GEORGIA	...
ILLINOIS	ILLINOIS	...	ILLINOIS	...	ILLINOIS	...
INDIANA	INDIANA	...	INDIANA	...	INDIANA	...
IOWA	IOWA	...	IOWA	...	IOWA	...
KANSAS	KANSAS	...	KANSAS	...	KANSAS	...
KENTUCKY	KENTUCKY	...	KENTUCKY	...	KENTUCKY	...
LOUISIANA	LOUISIANA	...	LOUISIANA	...	LOUISIANA	...
MAINE	MAINE	...	MAINE	...	MAINE	...
MARYLAND	MARYLAND	...	MARYLAND	...	MARYLAND	...
MASSACHUSETTS	MASSACHUSETTS	...	MASSACHUSETTS	...	MASSACHUSETTS	...
MICHIGAN	MICHIGAN	...	MICHIGAN	...	MICHIGAN	...
MINNESOTA	MINNESOTA	...	MINNESOTA	...	MINNESOTA	...
MISSISSIPPI	MISSISSIPPI	...	MISSISSIPPI	...	MISSISSIPPI	...
MISSOURI	MISSOURI	...	MISSOURI	...	MISSOURI	...
MONTANA	MONTANA	...	MONTANA	...	MONTANA	...
NEBRASKA	NEBRASKA	...	NEBRASKA	...	NEBRASKA	...
NEVADA	NEVADA	...	NEVADA	...	NEVADA	...
NEW HAMPSHIRE	NEW HAMPSHIRE	...	NEW HAMPSHIRE	...	NEW HAMPSHIRE	...
NEW JERSEY	NEW JERSEY	...	NEW JERSEY	...	NEW JERSEY	...
NEW YORK	NEW YORK	...	NEW YORK	...	NEW YORK	...
NORTH CAROLINA	NORTH CAROLINA	...	NORTH CAROLINA	...	NORTH CAROLINA	...
NORTH DAKOTA	NORTH DAKOTA	...	NORTH DAKOTA	...	NORTH DAKOTA	...
OHIO	OHIO	...	OHIO	...	OHIO	...
OKLAHOMA	OKLAHOMA	...	OKLAHOMA	...	OKLAHOMA	...
OREGON	OREGON	...	OREGON	...	OREGON	...
PENNSYLVANIA	PENNSYLVANIA	...	PENNSYLVANIA	...	PENNSYLVANIA	...
RHODE ISLAND	RHODE ISLAND	...	RHODE ISLAND	...	RHODE ISLAND	...
SOUTH CAROLINA	SOUTH CAROLINA	...	SOUTH CAROLINA	...	SOUTH CAROLINA	...
SOUTH DAKOTA	SOUTH DAKOTA	...	SOUTH DAKOTA	...	SOUTH DAKOTA	...
TENNESSEE	TENNESSEE	...	TENNESSEE	...	TENNESSEE	...
TEXAS	TEXAS	...	TEXAS	...	TEXAS	...
UTAH	UTAH	...	UTAH	...	UTAH	...
VIRGINIA	VIRGINIA	...	VIRGINIA	...	VIRGINIA	...
WASHINGTON	WASHINGTON	...	WASHINGTON	...	WASHINGTON	...
WEST VIRGINIA	WEST VIRGINIA	...	WEST VIRGINIA	...	WEST VIRGINIA	...
WISCONSIN	WISCONSIN	...	WISCONSIN	...	WISCONSIN	...
WYOMING	WYOMING	...	WYOMING	...	WYOMING	...

NEW 10% WAR BOND DRIVES SWELL TREASURY HONOR ROLL

HOW TO "TOP THAT 10% BY NEW YEAR'S"

Out of the 13 labor-management conferences sponsored by the National Committee for Payroll Savings and conducted by the Treasury Department throughout the Nation has come this formula for reaching the 10% of gross payroll War Bond objective:

- 1. Decide to get 10%.**
It has been the Treasury experience wherever management and labor have gotten together and decided the job could be done, the job was done.
- 2. Get a committee of labor and management to work out details for solicitation.**
 - a. They, in turn, will appoint captain-leaders or chairmen who will be responsible for actual solicitation of no more than 10 workers.
 - b. A card should be prepared for each and every worker with his name on it.
 - c. An estimate should be made of the possible amount each worker can set aside so that an "over-all" of 10% is achieved. Some may not be able to set aside 10%, others can save more.
- 3. Set aside a date to start the drive.**
- 4. There should be little or no time between the announcement of the drive and the drive itself.**
The drive should last not over 1 week.
- 5. The opening of the drive may be through a talk, a rally, or just a plain announcement in each department.**
- 6. Schedule competition between departments; show progress charts daily.**
- 7. Set as a goal the Treasury flag with a "T."**

As of today, more than 20,000 firms of all sizes have reached the "Honor Roll" goal of at least 10% of the gross payroll in War Bonds. This is a glorious testimony to the voluntary American way of facing emergencies.

But there is still more to be done. By January 1st, 1943, the Treasury hopes to raise participation from the present total of around 20,000,000 employees investing an average of 8% of earnings to over 30,000,000 investing an average of at least 10% of earnings in War Bonds.

You are urged to set your own sights accordingly and to do all in your power to start the new year on the Roll of Honor, to give War Bonds for bonuses, and to purchase up to the limit, both personally and as a company, of Series F and G Bonds. (Remember that the new limitation of purchases of F and G Bonds in any one calendar year has been increased from \$50,000 to \$100,000.)

TIME IS SHORT. Our country is counting on you to—

"TOP THAT 10% BY NEW YEAR'S"



Save with War Savings Bonds

This space is a Contribution to America's All-Out War Effort by ELECTRONIC INDUSTRIES

an airplane propeller in minutes, compared to hours required by ordinary heat and pressure methods. Radio high-frequency furnaces are a post-war prospect. In them railroad ties will be seasoned quickly and cakes of textiles dried uniformly. Even rubber may be radio-cemented to wood or plastic; cloth stitched and seamed by radio heat; metals hardened; plywood glued, and fresh vegetables deactivated without loss of flavor or color. The possibilities in this new thermic realm of radio are unlimited, as indicated by remarkable advances in RCA Laboratories during the year."

To Concentrate on These Tube Types

After study of the replacement-tube situation in connection with civilian receivers, the War Production Board has decided not to limit tube manufacture to certain types, as was at first planned. Instead, tube manufacturers are now being encouraged to concentrate production on the types in which shortages are most acute, as follows:

OZ4	6B8GT	7A8	35L6GT/G
1A5GT/G	6C6GT/G	7B5	35Z3
1A7GT/G	6C8G	7B7	35Z5GT/G
1C5GT/G	6E5	7C5	36
1H6GT/G	6F5GT/G	7C6	37
1LA4	6F6GT/G	7C7	38
1L34	6F8G	7F7	39
1LC6	6H6GT/G	7H7	41
1LD5	6J6GT/G	7J7	42
1LE3	6J7GT/G	7N7	43
1LH4	6K5GT	7V7	45
1LN6	6K6GT/G	7Y4	47
1N6GT/G	6K7GT/G	12A8GT	50L6GT/G
1P6GT/G	6K8GT/G	12B6GT/G	50Y6GT/G
1Q6GT/G	6L6G	12K7GT/G	56
1T6GT/G	6L7GT	12Q7GT/G	57
1V	6N7GT/G	12SA7GT/G	58
2A3	6Q7GT/G	12SJ7GT/G	70L7GT
2A5	6R7GT/G	12SK7GT/G	71A
3Q6GT/G	6SA7GT/G	12SQ7GT/G	75
504G	6SC7GT	14A7/1237	76
5V4G	6SD7GT	24A	77
5X4G	6SJ7GT/G	25L6GT/G	78
5Y3GT/G	6SK7GT/G	25Z5	80
5Y4GT/G	6SQ7GT/G	25Z6GT/G	83
5Z3	6U5/6G5	26	84/6Z4
6A7	6V6GT/G	27	117L7/M7GT
6A8GT/G	6X5GT/G	30	117Z6GT/G
6BT	7A4	35	
	7A6	35A5	

Of the above general list, the worst shortages have appeared in the following type numbers: OZ4, 25L6GT/G, 25Z6GT/G, 35L6GT/G, 50L6GT/G, 50Y6GT/G, 117L7/M7GT, and 117Z6GT/G. There are also shortages among some of the group in the third column, beginning with 12.

The present WPB recommendation to spend production on the above types will apply to the first quarter of 1943, after which new recommendations will be forthcoming.

Philips Dutch Plant Bombed

P. F. S. Otten, president of N. V. Philips' Gloeilampenfabrieken (Philips Incandescent Lamp Works), announced that the company's Germanheld plants at Eindhoven, Holland, were bombed on Dec. 6th, by the R.A.F. Both the electric lamp and radio tube factory in town, and the radio-set fac-

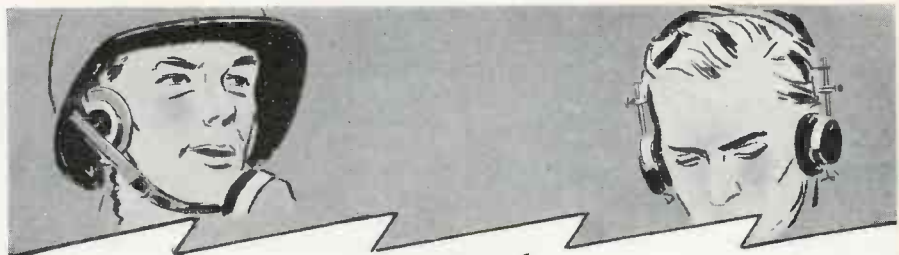

Everybody in Radio Knows Murdock!



BEHIND today's war production at Murdock is 39 years of "know how"!

In 1904 William J. Murdock saw clearly that sensitive Radio Phones could be made only by precision methods. He manufactured each part with scientific exactness.

In each year since, requirements for Radio Phone sensitivity and durability have become increasingly strict. Murdock has kept pace.

Today the U. S. Army Signal Corps and Air Corps take most of our production. Murdock Radio Phones must be right to meet their specifications.

Ask anybody in Radio—they know Murdock! Catalogue on request—write to Dept. 68.







Murdock RADIO PHONES

MURDOCK MANUFACTURING CO.
CHELSEA, MASSACHUSETTS

Luxtron

PHOTO ELECTRIC CELLS

IN **ANY** . . .

Size - Type - Shape
Capacity

EQUAL TO **ANY** . . .
REQUIREMENTS

The widest range of scientific and industrial requirements can be met by Luxtron Cells—the Cells that meet the stringent requirements of the Army and Navy. For measurements, analysis, indication, metering, control, signal, inspection, sound reproduction, etc. Luxtron Units can also be produced to meet special needs.



USED TO

PRE-TEST

Bomber Pilots

IN STRATOSPHERE
CHAMBERS

Luxtron Photo-Electric Cells in Stratosphere Chambers, where pilots are pre-tested, have to meet the most severe conditions of cold, humidity, vibration. The fact that they satisfy the Army and Navy requirements is proof that they can meet the most particular specifications of all commercial and industrial applications.

• Write for special illustrated literature with complete technical data. We are at your service for consultation on special problems.

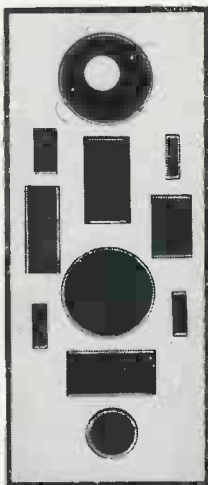

Luxtron*

PHOTO ELECTRIC CELLS
BRADLEY LABORATORIES, INC.
81 MEADOW ST. • NEW HAVEN, CONN.

tory and glass works outside the town, covering a total of 78 acres, were seriously damaged. (Pictured on opening pages of this issue).

"Of course, Mr. Otten said, "we do not know just what the Germans have been producing in the Eindhoven factories lately or to what extent they have looted it of machinery and materials. When I was in London a few months ago, however, I was given to understand by United Nations sources that the Dutch personnel in the plants behaved marvelously under the prevailing circumstances.

"I was glad to see from the news dispatches that the R.A.F. planned the bombing for noon on Sunday and flew low, so as to injure as few of the Dutch people as possible, although this daylight low level flight made the feat much more dangerous."

The Eindhoven plants were erected at a cost of more than \$60,000,000. Major Phillips products are electric lamps, radio receiving sets, radio tubes, radio transmitting apparatus, television receivers and transmitters, X-ray tubes and apparatus, sound film equipment, sound amplifiers, apparatus and parts for line and wireless telephony and telegraphy, and a number of industrial articles.

Mr. Otten is president of North American Phillips Co., Inc. which has plants at Dobbs Ferry, N. Y., and Lewiston, Me., producing chiefly radio articles for the United States Army. An affiliated company, Philips Metalix Corp., with a plant at Mt. Vernon, N. Y., produces X-ray tubes and apparatus for military purposes.

Pentagon Now Houses Signal Corps

The Army Signal Corps is now housed for the first time almost entirely under one roof—the huge Pentagon Building at Arlington, Va., having been moved into its new quarters during December.

The offices of Major General Dawson Olmstead, Chief Signal Officer, and Brigadier General James A. Code, Jr., Deputy Chief Signal Officer and Chief of the Signal Operating Services, together with the staffs under Brigadier General Frank A. Stoner, Chief of Army Communications Division, and under Brigadier General C. M. Milliken, Chief of the Signal Troops Division, were transferred from the Munitions Building early in December. The Executive Staff of the Chief Signal Officer, including the Directorate of Planning and Executive Office, were also moved.

The Signal Corps staffs occupy wings on the east side of the Pentagon Building in close proximity to each other. Last summer the Sig-

nal Supply Services under Major General Roger B. Colton and the Control Division under Colonel C. O. Bickelhaupt had been moved to the Pentagon, so that all the Corps activities, except for certain units still in the Munitions Building, are now under one roof.

OCD Urges More WERS Stations

Emphasizing the Office of Civilian Defense's interest in the licensing of more War Emergency Radio Service stations in the South Atlantic, Gulf and Pacific Coast states, Dr. C. D. Hargis, new chief of the OCD Communications Unit, points out that, while over 65 WERS stations have been licensed by the FCC to date, most of them are concentrated in the North Atlantic coastal area. The OCD is preparing a Manual for the Operation of War Emergency Radio Service Stations which will shortly be in the hands of all licensees.

Dr. Hargis, who took over the OCD post in October, is a former Research Director of the old Victor Talking Machine Co. and from 1929 to 1931 was in charge of special developments at RCA. Since 1931, he has operated his own laboratories in New Jersey and served as radio engineer for the New Jersey State Forest Fire Service. In that position he was responsible for the establishment of a state-wide network of ultra-high frequency units for mobile communications in connection with forest fire protection.

The holders of the 65 blanket licenses granted so far by the FCC, covering several hundred individual transmitters, will be allocated a band of frequencies from 112 to 116 megacycles—ultra-high frequency channels which are good for local communication purposes and relatively safe from enemy interception.

Signal Corps Sets Up Field Offices

To expedite its inspection duties, the Signal Corps Inspection Agency, which is responsible for handling the inspection and acceptance of Signal Corps materiel at manufacturing plants, has established five Signal Corps Inspection Zones.

Zone offices, headed by Colonel Lester J. Harris, have been designated as exempted stations under the direct control of the Chief Signal Officer. A small section will remain in Washington to maintain liaison.

Principal reasons underlying new organization are the elimination of duplicate inspections at manufacturing plants; the reduction of distance between the inspection units and the headquarters to which they report; and the promotion of uni-

formity in Signal Corps inspection policies and procedures.

The zones headquarters with their commanding officers are: Newark, Major Frank Prina; Philadelphia, Major R. E. Roesch; Dayton, Lt. E. B. Evans; Chicago, Major E. A. Koerner; San Francisco, Lt. R. F. Hawley.

C. E. Wilson Now Supervises Radio

Charles E. Wilson, WPB Production Vice-Chairman, under the new agreement between Secretary of War Stimson, Secretary of the Navy Knox and WPB Chairman Nelson, settling the recent dispute over production and scheduling supervision, has among his duties central supervision and direction of the production program of radio and detection equipment.

He exercises these duties through the supply and procurement branches of the services—the WPB Radio and Radar Division (Ray C. Ellis, director) under him working closely with the Army Signal Corps and the Navy's Bureau of Ships Radio Division.

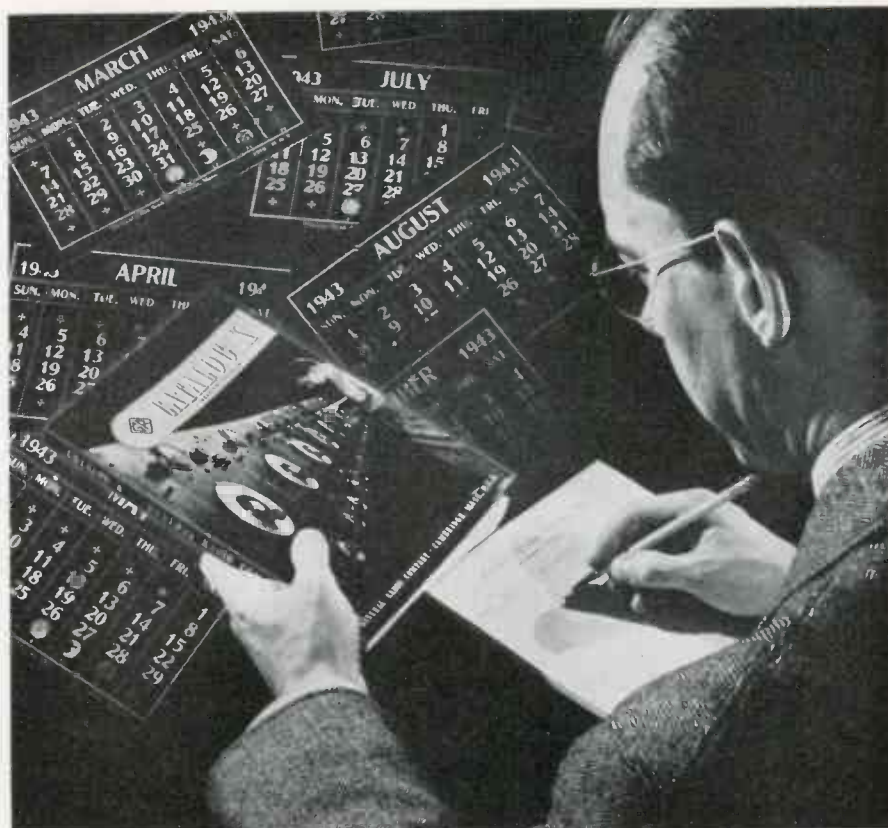

Admiral Hooper, the Navy's No. 1 Radio Man



Admiral S. C. Hooper, long head of Naval Communications and other Navy radio activities, visits Zenith's Chicago factory on a tour of inspection with Comdr. K. W. Miles

Enemy Patents Available to U. S. Mfrs.

Around 2,000 radio and electronic patents have been seized from Axis-dominated countries and registered with Alien Property Custodian Leo Crowley. To date, roughly 1,672 patents in the "Radiant Energy" classification have been con-

Forecasting Deliveries of TEST EQUIPMENT for 1943

YOU can help us to schedule production for 1943 more efficiently so that you will be better assured of getting General Radio instruments when you need them. Estimate your test equipment requirements when you plan your own production and place your orders with us well in advance of the desired delivery dates.

Our present plant output is completely allocated, and current orders will be delivered early in 1943. If you will need instruments for use in late spring and summer, order them now, specifying the desired delivery dates. Ordering well in advance will help to assure on-time deliveries. On the other hand, please do not call for delivery ahead of actual needs, and thus prevent someone else from getting urgently needed equipment on time. Your co-operation will help us to deliver what you want, when you need it.



GENERAL RADIO COMPANY
Cambridge, Massachusetts



Wholly or semi-automatic waxing machine showing pilot lights and instrument control of wax and air temperatures and electrical and mechanical operations.

Automatic HOT-WAXING OF SMALL PARTS

USE THIS NEW, HIGH-SPEED,
LOW-COST METHOD OF
MOISTURE-PROOFING TO
PREVENT RADIO-FAILURE IN
THE STRATOSPHERE OR ON
THE GROUND

Moisture-laden clouds—banks of fog—mist, drizzle and downpour—always have been troublemakers for radio sets—in planes, tanks, mobile and fixed communication services.

While the menace of dampness and humidity has compelled moisture-proofing in radio, as in many other industries, it is no longer necessary to do wax-coating by manual methods, which are often slow, wasteful and uncertain.

This new Dipping, Impregnating and Centrifuging machine was developed in collaboration with one of the largest government contractors making airplane radio parts and equipment. It is expressly designed for the hot-waxing of mica, plastic or porcelain parts, coils, etc., to increase the surface leakage resistance. We also build equipment for automatic enameling-lacquering, and hot tin dipping of small parts.

The machine is unbelievably economical, simple, fast and sure. It will coat extremely thin edges, punch holes, etc., and will impregnate a material to the full extent of its porosity.

Machines may be leased on high priorities or you may have your parts coated by us on an economical contract basis.

Write or wire for full details

**PRODUCTION ENGINEERING
CORPORATION**

660 VAN HOUTEN AVE., CLIFTON, N. J.
Phone Passaic 2-5161

fiscated; 449 in the telegraphy and television groups, and 125 in the "Electric Signalling" category.

Lists of the patent descriptions in these groups at nominal cost are available upon request from the Alien Property Custodian at Chicago. Lists of Class 250—radiant energy and Class 178—telegraphy are priced at \$.25, while Class 177—electric signalling—sells for only a dime. The latter two classes each have some radio devices in their lists.

Licenses under enemy patents and patent applications not already exclusively licensed will be issued on application to any legitimate American business concern on a royalty-free, non-exclusive basis for the life of the patent. Only cost to the licensee is a \$50 fee for a license under a single patent, plus \$5 for each additional patent covered by the license. In addition, the licensee is obligated to keep a record and report to the Custodian the extent he is using his patent privileges.

Radio Engineer Added to ASA Staff

The new program of the American Standards Association for the development of standards requested by the War Production Board and the Office of Price Administration has made it necessary for the ASA to expand its staff to take care of the new work. A new radio department has been set up, with H. R. Wilsey as radio engineer, working under the supervision of J. W. McNair, ASA electrical engineer.

H. R. Wilsey, the new ASA radio engineer, was formerly with the

Underwriters' Laboratories in New York, where he worked on radio testing and on preparation of the standards which the Laboratories use as the basis for their listing of accepted items. Mr. Wilsey graduated from the Massachusetts Institute of Technology in 1936, having majored in electrical engineering and communication. He has been with Underwriter's Laboratories since 1937.

Brooklyn Poly Courses in UHF

Dr. Ernst Weber, director of department of graduate electrical engineering of the Polytechnic Institute of Brooklyn, N. Y., announces another group of graduate war training courses in ultra high frequencies and allied subjects, to train men in research laboratories of the war industries.

Courses on the theory of cathode-ray circuits and microwave theory were scheduled to start early in January. Experiments in cathode-ray circuits and microwaves, and a course in the theory of uhf generators and receivers, will begin Feb. 1. Measurements at uhf begin about March 1.

New Langevin Transformer Plant

The Langevin Company has just completed its new transformer plant at 37 West 65th Street, New York City. This plant will specialize in the manufacture of electrical transformers of all types for use in radio and radar communication work. Area occupied totals approx-

NBC Committee on Engineering Developments



To study new broadcast services, NBC has set up group comprising, left to right: R. E. Shelby, development engineer; Charles B. Brown, advertising director; Raymond F. Guy, radio facilities engineer; O. B. Hansen, vice-president and chief engineer; Dr. Alfred N. Goldsmith, consulting engineer; John F. Royal, vp international broadcasting, and N. E. Kersta, television manager

imately 16,000 sq. ft. Complete tool-room facilities are incorporated in order to expedite fabrication of parts normally procured through outside sources.

Stancor Dinner

The Standard Transformer Corp., Chicago, held a dinner at the Standard Club, Chicago, for 105 of its employees who have served the firm for five years or longer. Honor Awards were given.

Guest speakers included Lt. Col. Boruszak, Lt. Com. George C. Norwood, Majors H. E. Billington, Major Eldon A. Koerner, Major Leo E. Steiner, Jerome J. Kahn and Levi Anderson. Kenneth C. Prince acted as Toastmaster.

Hassler in Washington

Bert Hassler, for many years associated with Frazar & Co., San Francisco export agents, and now representing them in Washington, D. C., has opened quarters in the Annapolis Hotel in the nation's capital. He will also act as export agent for the Universal Microphone Co., Inglewood, Cal. Frazar and Co. has represented the Universal foreign business for many years.

Radio-Formula and Data Book

Allied Radio Corporation, 833 Jackson Boulevard, Chicago, has issued a new pocket-sized handbook of most frequently used mathematical formulas, tables, data, and standards in the field of radio and electronics. This booklet, edited by Nelson M. Cooke, Chief Radio Electrician, U. S. Navy, eliminates time-taking search through numerous books for information constantly used by radio and electronic engineers and maintenance men.

Available for instant reference are formulas, tables, and data covering such subjects as Ohms' Law;

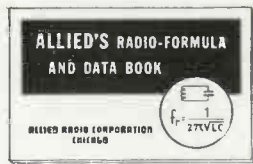

inductance; reactance; impedance; resonance; the use of exponents, trigonometric relationships, logarithms, radio color codes, abbreviations, mathematical symbols, wire tables, etc. Included also is a condensed selection of formulas pertaining to meters and vacuum tubes.

The booklet is priced at 10c. However, free copies will be sent to engineers who send in requests on firm letterheads.

Coupled to the War Effort

in a hundred ways, Cardwell is also tied into almost every type of communication equipment through the extensive use of Cardwell Flexible and Rigid Insulated Couplings to isolate radio frequency controls.



When the type "A" Coupling was first designed, even though we believed it to be "tops," we hardly expected the tremendous acceptance it now enjoys. Since it seems minute in comparison to the larger units, we have "blown up" a separate view of this most popular of all the Cardwell Couplings, to better indicate its construction.

Type "FNF" is the most widely used of the rigid types, while type "C" and "E" are the standard flexible units for higher voltage and torque. Type "D" and "F" are special and not so readily obtained.

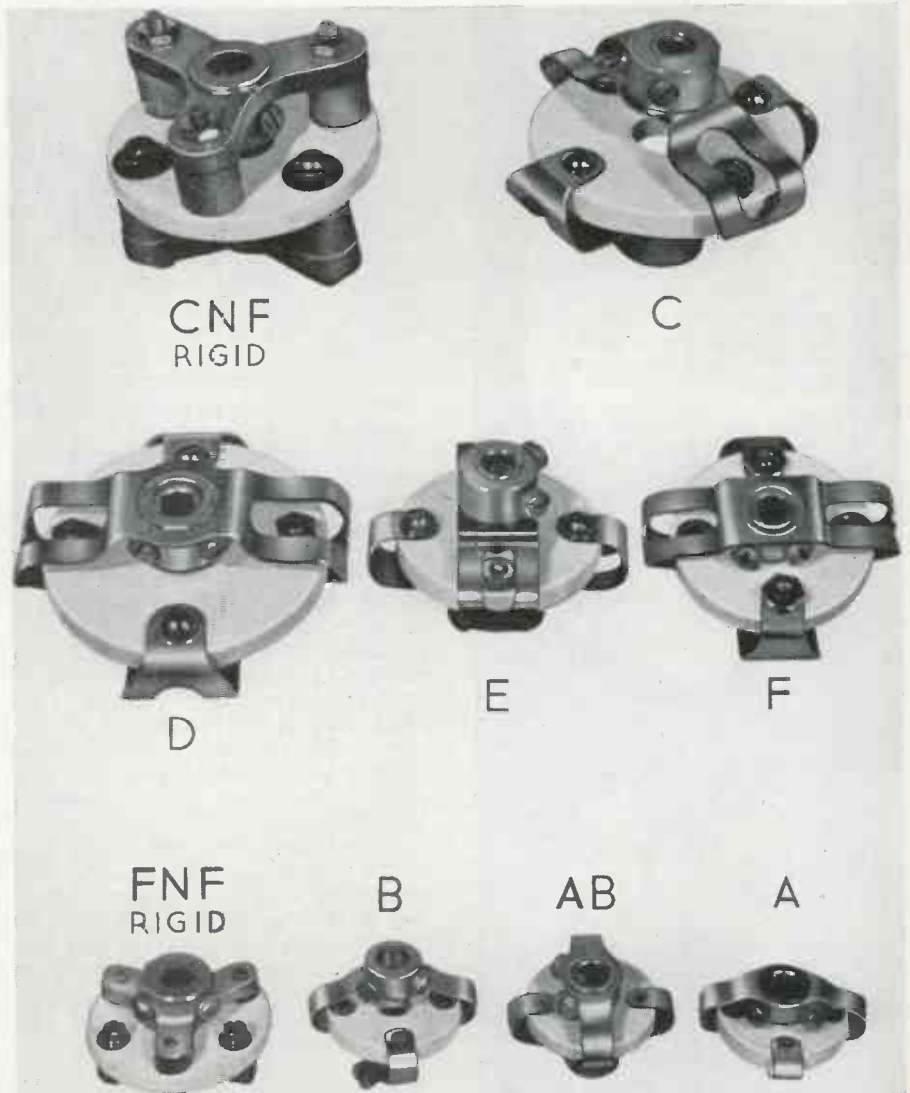

Manufactured of critical materials, including phosphor bronze springs, brass hubs, Alsimag #196 insulation, case hardened cup point steel set screws, etc., highest priorities are required to insure delivery of these small items, so vital, however, to communications equipment and therefore of priceless importance.

CARDWELL CONDENSERS

THE ALLEN D. CARDWELL MANUFACTURING CORPORATION

BROOKLYN, NEW YORK

**"..IN-RES-CO
resistors for
minimum of
inductance"**



★ Production men will tell you that these compact units meet the current widespread demand for greater adaptability without sacrificing electrical characteristics. Produced by specialists in the wire wound resistor field, IN-RES-CO products include fixed and variable resistors, meter shunts, choke coils, solenoids, etc.

If a special resistor is required to meet a critical application, IN-RES-CO engineers will collaborate in solving the problem. Write today for illustrated literature.

TYPE WL, 1 watt, standard tolerance 1%, maximum resistance 50,000 ohms, size 3/16" x 1" long. Mounting by terminals, strap type, .015" thick by 1/16" wide tinned copper. Special terminals can be supplied at any angle desired.



NEW BOOKS

Ultra-High-Frequency Techniques

By J. G. Brainerd, Glenn Koehler, H. J. Reich and L. F. Woodruff, published by D. van Nostrand Company, Inc., New York, 1942, 570 pages, \$4.50.

This timely text covers a course now being given in engineering schools and colleges all over the country to graduate engineers and senior students in electrical engineering and physics. The course is aimed to relieve the shortage of manpower trained in these relatively recent and more advanced techniques, which are becoming increasingly important in the war. The book is practical, in as much as mathematics has been employed only to supply essential basic theory or to describe elements and circuits. No mathematical difficulties will be experienced by the average engineering graduate in the first half of the book, which presents a review of standard communications and leads up to the more difficult chapters on radiation, hollow wave guides, and U-H-F theory and practice. The going may get somewhat tough there, and the reader may do well to get some knowledge of vector theory, electromagnetic fields, Bessel functions, partial differential equations, etc.

It was inevitable, that in a text intended to prepare the student for U-H-F problems as its final object, the emphasis of the various chapters had to be shifted to suit this purpose, and therefore one should not be disappointed to find rather sketchy sections on fundamentals of tubes, radio receivers and transmitters, and other subjects well covered by other texts. On the other hand, much unconventional and new material, not generally found in standard communication texts, has been included, as for instance: Analysis by use of Fourier integrals, excellent treatment of voltage stabilizers, video amplifiers, cathode-ray tubes and trigger circuits, as well as FM modulation, demodulation, FM receivers and transmitters. Chapter 10, somewhat abruptly goes into the subject of U-H-F generators. One regrets, that the later chapters on transmission lines, radiation and propagation have not been presented first, in order to ease the transition and change in viewpoint occurring in going from lumped parameter circuit theory to the electromagnetic wave theory. Chapter 12, deriving the basic laws of electromagnetic theory (Maxwell's equations) and presenting a table showing the analogies between lumped parameters, as voltage, resistance, etc., and field con-

ceptions, as field intensity, resistivity, etc., would be very helpful to the student before considering the actual methods of obtaining U-H-F. This chapter also contains a meaty summary of antennas, their radiation resistance, input impedance, directional properties, arrays and reflectors.

Principles of Electronics

By Royce G. Kloeffler, S. M., published by John Wiley & Sons, Inc., New York, and Chapman & Hall, Ltd., London, 170 pages, \$2.50.

Intended as a short introductory course in electronics for either sophomore or junior students, the book covers structure and performance of electron tubes and various applications. It may also be extremely helpful to a beginner with no previous training and unfamiliar with the subject but anxious to get a basic working knowledge in a comparatively short period of time. The treatment is simple and thorough. The behaviour of tubes is stated, illustrated, and explained in clear and precise language without the use of mathematical formulas.

The author feels that the extreme simplicity of action taking place in the electron tube justifies the unusual procedure of teaching electronics as the first course in electrical engineering. This, however, only applies to the electrostatic problems within the tube. Electronics, involving in addition stationary and quasistationary electromagnetic fields, does not seem to be the easiest approach to the study of electricity.

Microwave Transmission

By J. C. Slater, Professor of Physics, Massachusetts Institute of Technology, published by McGraw-Hill Book Company, Inc., New York, 1942, 310 pages, \$3.50.

According to the author "Microwave transmission is such a new subject that the workers in the field, as well as students, should be interested in a book like the present one, bringing together considerable material that has been developed largely during the last 10 years and is now available only in the periodical literature."

Maxwell's equations are solved for special boundary conditions, corresponding to rectangular wave guides, parallel conducting planes, parallel wire transmission lines, coaxial cables and circular wave guides. If the computation is too involved or lengthy, it is indicated in general terms, the physical results stated and frequently illustrated by analogy.

NEW LITERATURE

Stroboscopic Techniques

"Eyes for Industry" is the title of a 25-pg. booklet issued by General Radio Co., Cambridge, Mass. which describes the types of stroboscopes manufactured by the company. Quantitative and qualitative measurements, typical uses, operating hints and techniques, photography and specifications are the subjects which are discussed and illustrated.

Prolonging Tube Life

"Thirteen Ways to Prolong Tube Life" is the subject of a useful booklet issued by Heintz & Kaufman, Ltd., South San Francisco, Calif. Because transmitting tubes are the heart of many instruments of war, our Armed Forces need more tubes than present manufacturing facilities can produce. Hence every transmitter man has a duty to nurse his tubes along and obtain from them their maximum useful life. The practical suggestions in this booklet have been prepared by the engineering department of Heintz & Kaufman to assist vacuum-tube users.

AC Welders

Ac and dc welding advantages are compared in a 12-page booklet by Westinghouse Electric & Mfg. Co., East Pittsburgh, Pa. Ac welders are stated to increase output because of the absence of magnetic arc blow, ease in using heavy electrodes with higher currents, and ability to make good welds in all positions.

A complete line of Flexarc ac welders, with current ratings from 100 to 500 amperes, is described and illustrated in the booklet. Featured are the 500 ampere industrial welder for high-speed, continuous welding on all types of heavy construction; and the 300-ampere portable welder for heavy-duty work. Both models have built-in power-factor correction.

Cellulose Plastics in War and Industry

A 64-page descriptive bulletin entitled "Cellulose Plastics in War and Industry" has just been issued by the Celanese Celluloid Corporation, 180 Madison Avenue, New York. The booklet outlines the functions of cellulose plastics for war in simple terms, and includes charts and tables for the engineer. The history of this plastic, the various materials manufactured by the company, their properties and working characteristics are all interestingly and pictorially described.

NATIONAL UNION IS READY TO GREET ELECTRONIC SERVICE MEN

FROM THE SMOKE AND TRIAL OF BATTLE SHALL ARISE
A GREATER, STRONGER SERVICE INDUSTRY

Every ounce of National Union energy is thrown into the battle for victory. Our engineering, our production, our manpower and machinery are in the fight. As we battle on the research and production front we see the dawn of great new horizons as new products, new and better methods develop; we see the Radio Service man to whom we have devoted ourselves through the years standing on the threshold of a greater opportunity than he has ever known. National Union is deeply grateful for the loyalty of the service profession to National Union products. National Union is learning, watching every advancement in the electronic art, so when the day of Victory comes, the many thousands of service men who have grown with us in the past shall benefit in the future.

NATIONAL UNION RADIO Corp. 57 STATE STREET, NEWARK, NEW JERSEY

Centralize
Your
Procurement
Everything in
Electronics and Radio
at
ALLIED

Send for Allied Catalog

Everything you need in Electronics and Radio is available from this one central source. Our large, complete stocks of over 15,000 items speed delivery. Our experienced staff solves your problems. Write, wire, or phone Haymarket 6800.

FREE—New Allied's Radio Formula and Data Book

Pocket sized. Contains essential Formulas, Tables, Data and Standards commonly used in Radio and Electronics. Free to Engineers, Purchasing Agents and Production Men. Write on Company letterhead for your copy.

ALLIED RADIO CORP.

833 W. Jackson Blvd. • Dept. 32-A-3 • Chicago

ALLIED RADIO



PROUD
TO SERVE

SNYDER
MANUFACTURING CO.
PHILADELPHIA, U. S. A.

RADIO
ANTENNAE
AND
ASSOCIATED PRODUCTS

NEW PATENTS

(Continued from page 84)

Noise Reduction—The modulated carrier wave is applied to a band pass filter, passing a range of frequency much wider than the desired signal. Upon demodulation, the amplitude is limited to substantially the desired signal which is then applied to a low-pass filter having a cut-off frequency just high enough to pass the most important frequency components of the desired signal, thereby attenuating the noise voltages, which are substantially eliminated in the following amplitude-responsive transfer means adjusted to transfer only a predetermined and selected portion of the signal. D. B. Smith, Philco Corp., (F) Aug. 19, 1939, (I) Dec. 8, 1942, No. 2,304,713.

Automatic Frequency Control—The natural frequency of a tunable concentric-line resonator is maintained synchronous with the frequency of the exiting oscillator. For this purpose, a voltage is derived from the feed line, coupling the oscillator and the inner conductor of

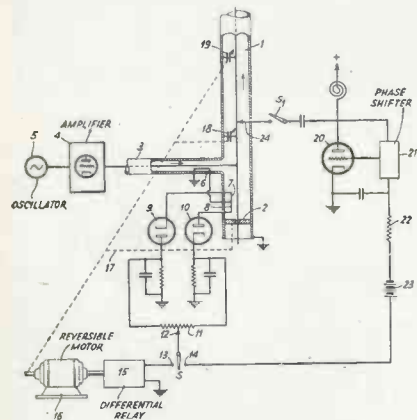

the resonator, and combined, respectively, with separate opposite voltages of equal magnitude taken from the resonator. Both combined voltages are rectified and the

resonator tuned in accordance with the difference of the combined, rectified voltages. W. van B. Roberts, RCA, (F) Feb. 11, 1941, (I) Dec. 8, 1942, No. 2,304,377.

Frequency Comparator—A first heterodyne voltage is produced, the frequency of which equals the frequency difference between a known, constant frequency and the unknown frequency. Simultaneously, another heterodyne voltage in phase quadrature with the first one is produced and its rate of change compared to the first heterodyne voltage. The intensity of the comparison voltage is a measure for the frequency variation of the unknown wave from the standard, and the phase variation indicates the direction of the frequency variation. W. H. Wirkler, Collins Radio Co., (F) May 27, 1941, (I) Dec. 8, 1942, No. 2,304,134.

Diversity Receiver—A diversity system, intended to compensate for fading by simultaneous reception from several spaced antennas, is described for either FM or phase modulation. The received signals are amplified, and converted in separate channels. After the second IF amplifiers, accentuator amplifiers are arranged which amplify a stronger signal to a greater extent than a weaker signal, thus predominantly amplifying the energy of the antenna having momentarily the greatest received voltage. Little or no conflict due to relative phase fluctuations at the different antennas is occasioned, and the outputs of the accentuators are fed to one common limiter, detected and translated. H. O. Peterson, RCA, (F) Aug. 27, 1940, (I) Nov. 24, 1942, No. 2,302,951.

Directional Receiving System—The signal voltage derived from a directional antenna is impressed on a channel into which has been fed the signal voltage from a non-

directional antenna. An exalted, unmodulated, alternating voltage from the directional antenna is combined with the output of the above channel in a phase detection network. R. A. Weagant, RCA, (F) July 13, 1940, (I) Nov. 24, 1942, No. 2,302,902.

Short-Wave Dosimeter—The device described in the December issue of "Electronic Industries", page 75, "Measuring Strong HF Fields", is claimed in this patent. K. S. Lion, S. Strauss, (F) Oct. 23, 1940, (I) Nov. 24, 1942, No. 2,302,874.

Guiding System—A polarized visual indicator is controlled by a yoke with several coils. The direct current impulses of a radio receiver output, varying above and below a mean level, indicate deviations to the right or left of a desired course. The grids of two triodes are connected to the output of the receiver and have a resistor between them the midpoint of which is connected to a source of grid-bias potential. The coils form part of the inductive resistance in the plate circuits of the tubes, one moving the indicator in one direction, the other coil moving the indicator in the opposite direction. Means are provided for controlling the position of the indicator. Georges Edme Marcel perroux, International Standard Electric Corp., (F) December 9, 1937, (I) November 3, 1942, No. 2,300,593.

Scanning Device—An electrode of thin sheet metal is interposed in the path of a moving beam of electrons. The thickness of the sheet metal is so small that, as a result of the moving stream of electrons striking one side of it, a stream of electrons passes from the other side to an anode. Photoelectric means are provided for controlling the flow of electrons between the electrode and the plate and an output circuit is interconnected there between. Juichi Osawa, International Standard Electric Corp., (F) June 5, 1936, (I) November 3, 1942, No. 2,300,591.

Important Questions about the

ELECTRONIC Year Book & ENGINEERING DIRECTORY

to be published in March
as an integral section of

**ELECTRONIC
INDUSTRIES**

480 Lexington Avenue • New York

NEW LITERATURE

Switchboards

The Square D Co., 6060 Rivard St., Detroit, announces a revised edition of its bulletin No. 3000 on circuit breakers and fusible switchboards.

The bulletin contains illustrations, descriptions and specifications of various switchboards and circuit breaker units giving details of construction and material of parts as well as ratings.

1. Have you filled out and returned the editorial questionnaire giving data for your free listings? If not, please do so at once.

2. If you are a manufacturer of radio-electronic equipment and have not received your questionnaire, advise us at once.

You need this

GEARED-TO-THE-WAR MAGAZINE

ELECTRONIC INDUSTRIES

bringing you

Vital information that every engineer and every executive must have to keep abreast of wartime electronic activities.

This magazine, edited especially for those who design, manufacture or operate electronic equipment, is a virtual Report Center for electronic activities. It keeps you informed. In every phase of this fast-moving field, it helps you to meet the problems of the day.

You are now reading the first issue. It speaks for itself. It is chock full of meaty, factual information which shows how *much* you have needed before never before had.

ELECTRONIC INDUSTRIES takes you on a monthly trip to Washington, the focal point of everything electronic. It takes you on frequent visits to the FCC, source of new regulations, and other government services. It takes you to radio-electronic factories, communications services and industrial plants where advances are made in application, installation, and operation.

The engineer who must shoulder an increasing executive responsibility, and the executive who must have a better point of view on engineering matters will recognize in this new magazine a priceless recording of fact and experience.

Order Your Subscription Today

USE THIS POSTCARD — WE PAY POSTAGE

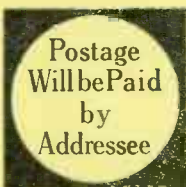

BUSINESS REPLY CARD

First Class Permit No. 22273, Sec. 510, P. L. & R., New York, N. Y.

ELECTRONIC INDUSTRIES

480 LEXINGTON AVENUE

NEW YORK, N. Y.



In Washington



In War Production



In the Field

- | | |
|-------------|----------------|
| DESIGN | SPEEDUPS |
| MANUFACTURE | SUBSTITUTES |
| APPLICATION | SHORT CUTS |
| OPERATION | SIMPLIFICATION |
| MAINTENANCE | RESEARCH |

Photos above—Top, H. Armstrong Roberts; Center, R. C. A.; Bottom, O. W. I. photo by Palmer.

ELECTRONIC INDUSTRIES

*The less spare time you have,
the more you need it!*

NEWS — INTERPRETATION — ENGINEERING FEATURES — REVIEWS

Developments affecting electronic activities 24 hours a day
in factories and services everywhere.

ELECTRONIC INDUSTRIES serves two rapidly-expanding groups of in-
dustries, tightly drawn together by a common dependence upon the
electron tube.

—The industry in which electronic equipment is designed, manufactured
and sold.

—The scores of industries in which electronic equipment is installed, oper-
ated and maintained.

you are professionally engaged as a design engineer or production execu-
tive in a radio-electronic factory—as an operating or maintenance engineer
in a communication service or broadcast station—as an engineer of design
or procurement in government service—you will find that ELECTRONIC
INDUSTRIES gives you a critically needed information service.

you are an engineer, supervisor or technician in an industrial plant using
electronic apparatus—in such industries as food and beverage; transpor-
tation, power and other utilities; chemical, milling, mining and refining;
petroleum, machinery, textiles, plastics and many others—you will find that
ELECTRONIC INDUSTRIES gives you a practical workaday service never
before available.

*Your subscription will start with the next issue
if you mail this postcard today.*

A BIG \$3 WORTH—2 YRS. \$5

Limited monthly editions—Subscribe
NOW—Use this card or order
on your letterhead

WANT ELECTRONIC INDUSTRIES EVERY MONTH!

For the following subscription to ELECTRONIC INDUSTRIES for the period
indicated below and mail bill with next issue.

Please check 1 Year \$3.00 2 Years \$5.00

Name _____ Title _____

Position you now hold _____

Name of your Company _____

Company Address _____

State _____

Magazine is to go to your home fill in here:

To ensure an efficient, waste-free service and a straight line electronic readership, the publisher
reserves the right to reject any subscriptions other than from those professionally active.

Be sure you fill this card in completely. Thank you!



DR. ORESTES H. CALDWELL, Editor of ELECTRONIC INDUSTRIES, former Federal Radio Commissioner and spokesman for the radio industry in more than 300 coast-to-coast broadcasts on national networks.

SAYS A WELL KNOWN INDUSTRY LEADER

"Yes, Dr. Caldwell, after seeing advance proofs of your editorial pages, I can say most emphatically that the electronic field has never had a magazine like this before."

And a distinguished engineer writes:

"I now understand what you mean when you say that ELECTRONIC INDUSTRIES will help the engineer to take a greater share of the executive responsibility."

*And without extra cost, you
also get a series of monthly
charts which will include*

4 SPECIAL CHARTS of great educational value

Note the 4-color Spectrum Chart, loosely inserted in this issue. This is the first time that the tube family has been shown in association with the frequency spectrum, indicating the most suitable frequency range for application of the various types of tubes.

Three more highly instructive charts will be published within your subscription period. You will want them all—especially the next one, a new color chart of air stratas and wave reflection.

Another, equally useful, will be a Market Chart of the electronic industries.

SOME FUNDAMENTALS OF SOUND

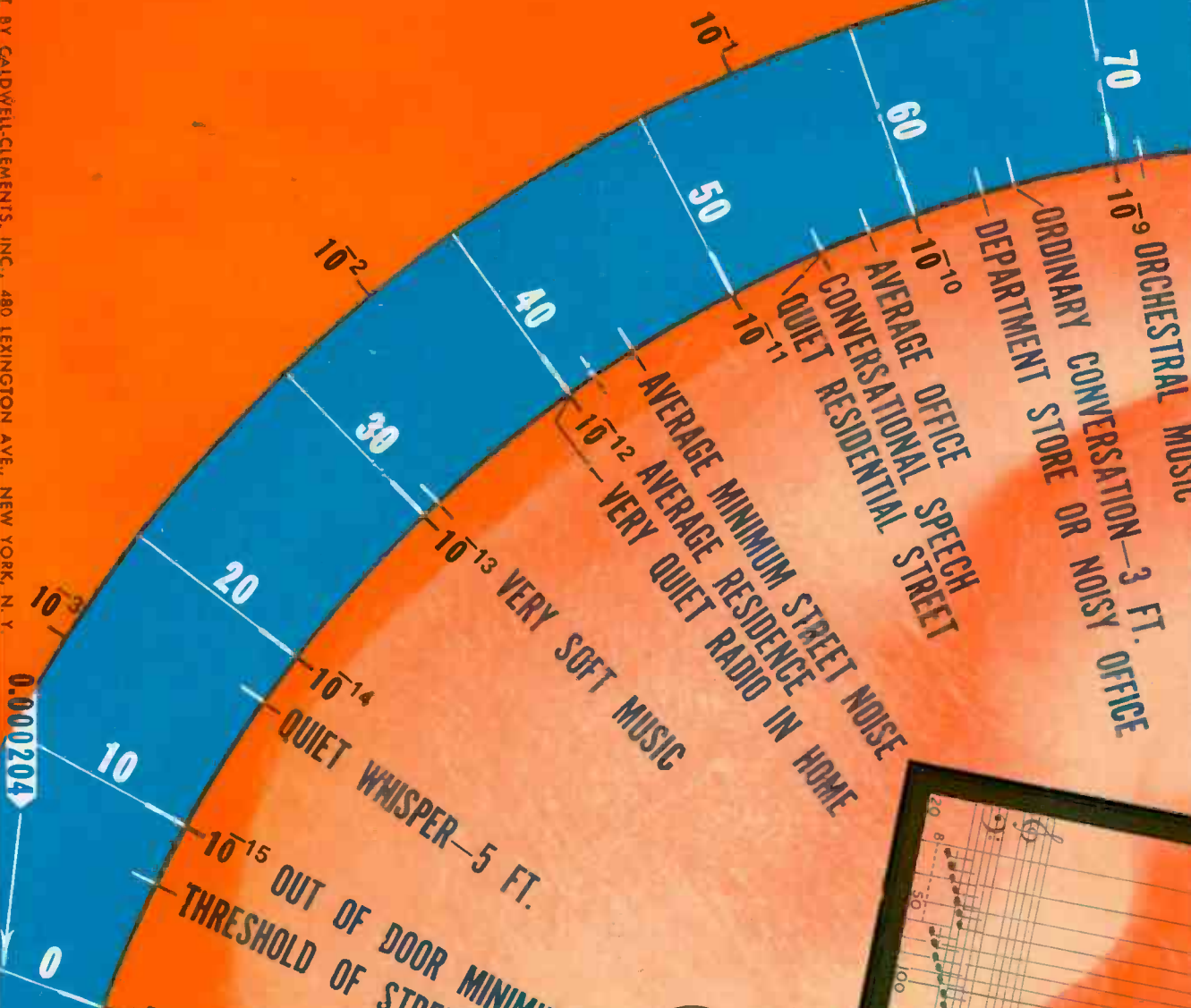

SOUND BASIC FORMULAS AND CONSTANTS

- 1) VELOCITY**— 331 met./sec } air at 0°C (32°F) and 1 atm.
1086 ft./sec }
1422 met./sec } water at 15°C (59°F)
4700 ft./sec }
1500 to 4000 met./sec } earthquake surface w
5250 to 13120 ft./sec }
- 2) RANGE**— Subaudible 0 to 16 cycles/sec
Audible 16 to 22,000 cycles/sec
Supersonic 22 to 5 x 10⁵ kilocycles/sec
- 3) SENSATION LEVEL IN DECIBELS**—
 $S = 20 \log \frac{p}{p_0}$
where p = sound pressure
 p_0 = threshold pressure (2×10^{-4} dyne/cm)
- 4) RANGE OF AUDIBLE INTENSITIES**—
132 db (—7 to 125 db)
- 5) SOUND POWER**— $J = 2.4 \times 10^{-8} p^2$
where J = microwatts/sq. cm.
 p = pressure in dynes/sq. cm.
Representative Sound Powers
Minimum Audible 2×10^{-17} watts/sq. cm.
(between 3000-4000 cycles/sec)
Speech
Average 1×10^{-5} watts
Peak 2×10^{-3} watts
Orchestra (75 pian
Average 15 w
Peak 65 w

and in a medium of a density of 0.005 gcm^{-3} is said to be approximately 60 cm sec^{-1} , which is about the velocity with which the sunspot zone moves towards the equator during sunspot cycle.

Gaseous Discharge Lamps

Wm. W. Gunn (Australasian Engineer, Sept. 1942)

One of three papers read at a meeting of the Illuminating Engineering Soc. of Australia is an article dealing with the manufacture, characteristics and technical applications of gaseous discharge lamps.

Construction and installation of mercury and sodium vapor lamps, supply voltages, color and brightness are discussed. Fluorescent powders and their application to lamp bulbs are described and data for lamps with and without fluorescent coatings are tabulated.

It is stated that lamps provided with a special filter, absorbing the visible light almost completely while allowing the ultra violet radiation to pass freely, are being used in the surfacing of metal, where the Prussian blue or French rouge is replaced by a solution of anthracene and paraffin and the high spots observed by fluorescence.

HF Tuned-Anode Tuned-Grid Oscillator

G. P. Pollard (Electronic Engineering, London, Oct. 1942)

An equivalent circuit for a tuned-anode tuned-grid oscillator is shown, taking into consideration the interelectrode grid-plate capac-

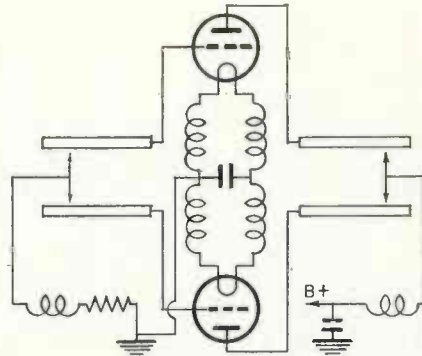

High frequency oscillator

ity, as is required for high frequencies. It is derived that oscillation can be set up only if both grid and plate circuit have inductive reactance and that the oscillator frequency will be less than the natural frequency of any of the tuned circuits. If a change in oscillator frequency is desired, both circuits must be tuned. Vector diagrams showing the relationship between voltages and currents in the arrangement are shown and discussed.

It is pointed out that if the Q factor of the grid circuit is made high by using a quarter wavelength of transmission line and if the coupling of the line to the grid is loose, an oscillator can be constructed the frequency of which will be almost completely controlled by the grid circuit. An oscillator using a quarter wavelength of short-circuited line for each tuned circuit is shown. For constant grid current and negligible resistances, the output voltage of this oscillator will be proportional to the ratio of the effective inductances of plate and grid circuits.

Pulse-Rate Indicator

M. M. Schwarzchild and M. C. Shelesnyak (Review of Scientific Instruments, Nov. 1942)

The circuit shown in the sketch is intended for recording the cardiac action current impulses but may be used for any quasi-periodic phenomenon, in the range of from 1 kc to 24 kc if at each period an electrical impulse of the order of 1 mv can be provided.

The meter indications are dependent upon pulse rate and independent of wave amplitude and shape. This is accomplished by two gas-filled trigger tubes, the first, grid-controlled tube setting off the discharge of another plate-controlled, gas-filled tube, the current of which passes through the meter indicating the average current. Provisions are made to reduce pulsation of the meter.

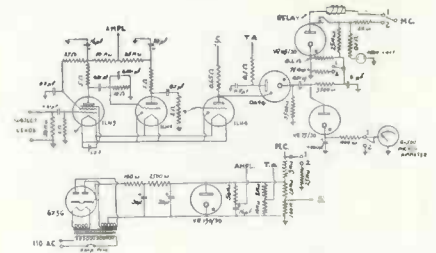

Pulse rate indicator

Considerations for the choice of the dimensions are discussed in detail, and results of tests using pulses varying in duration and in amplitude are shown. The arrangement was calibrated by means of a relaxation oscillator and repeated checking found it to be reliable within ± 5 per cent.

New Progress in Electron Microscopes



RCA's new "pocket" model, inspected by Dr. Zworykin and Dr. Hillyer. Only 16 inches long, it is capable of 100,000 magnifications, and is inexpensive enough to find wide use in smaller laboratories



GE's new unit as exhibited at Chemical Exposition in Chicago. Left to right, Dr. C. H. Bachman, co-designer; William C. White, director of GE electronic laboratory, and Dr. Simon Ramo, co-designer of instrument

SURVEY of WIDE READING

Electronic news in the world's press. Review of engineering, scientific and industrial journals, here and abroad

Stabilization of Cyclotron Field

H. Baumgartner, C. R. Extermann, P. C. Gugelot, F. Preiswerk and P. Scherrer (*Helvetica Physica Acta*, Basle, Vol. 15, 1942)

It is stated that the magnetic field of the cyclotron has to be constant within 0.02%. The voltage fed to the electromagnet, however, varies about 1 per cent. Control is effected by applying the deviations of the current from the desired value to a galvanometer operating a series of relays by means of two photoelectric cells and two thyatrons.

Quick adjustment of the current is required, but to reduce the time constant $T = \frac{L}{R}$ to half its value, the resistance would have to be $2R$, an extremely uneconomical solution of the problem causing a power loss of about 150 kilowatts.

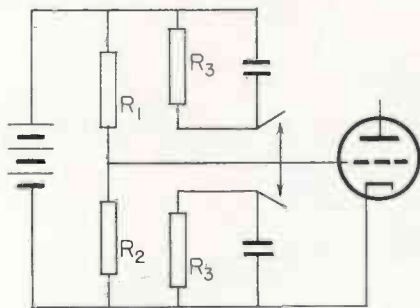

Exponential resistor

It was therefore decided to apply a voltage $E = E_0 + mE_1$, which is higher than the desired voltage $E_a = E_0 + E_1$, and to reduce it according to the formula $E_c = E_0 + E_1 [1 + (m-1)e^{-tm/T}]$, thus obtaining a time constant equal to T/m without introducing any additional dissipation. The actual circuit employed is shown in the diagram. The resistance of the triode having a grid voltage representing the desired variation may be considered equivalent to an exponential resistance with a time constant $T/m = C(R_1R_2 + R_2R_3 - R_3R_1)/R_1R_2R_3$

UHF Resonators

C. G. A. von Lindern and G. de Vries (*Alta Frequenza*, Italy, May 1942)

In its November issue, the *Wireless Engineer* reports an article on the coefficient of resonance in uhf circuits. If defined as the ratio be-

tween field energy and energy dissipated per period, the concept may be applied to circuits with distributed constants.

The behaviour of flat spirals and of a toroidal cavity resonator are described. It is stated that the resonance coefficient of a toroidal cavity resonator is proportional to its radius. To increase the resonance coefficient while raising the resistance at resonance, the inductive reactance may be increased by increasing the dimensions and eliminating any concentrated capacitance. The toroidal cavity thus passes into the Lecher coaxial system, or, when the dimensions attain the order of magnitude of a wavelength, into a resonant cavity.

FM Receiver

D. A. Bell (*Wireless Engineer*, London, Nov. 1942)

A method for reducing the band width in FM receivers and at the same time dispensing with the necessity of a separate limiter is described. According to this method, frequency-modulated signals are applied to a frequency discriminator circuit having an electrically controlled variable reactance as one of its tuning elements. This circuit is connected to a system of differential rectifiers whose output controls the variable reactance in such a way that the center frequency of the discriminator circuit, at which frequency its output passes through zero, follows the instantaneous frequency changes of the applied signal. Provided the variable tuning element has a linear control characteristic, the current in the control circuit will vary linearly with the changes in frequency of the applied signal and be independent of its amplitude; a portion of this current may therefore be used as detected output. Thus, by applying an extreme degree of negative feedback to an FM

receiver, what is termed a "frequency following" receiver is arrived at.

It is pointed out that it would be an obvious expedient to vary the frequency of the local oscillator in linear relation to a voltage applied to it from the discriminator, so as to keep the IF signal on the center frequency of the discriminator. It is argued that in this case, the band width required, for IF as well as for the discriminator is equal to the radio frequency band width or twice as much in systems having two side bands.

A schematic diagram of a superheterodyne receiver is shown in the figure. Formulas corresponding to the performance of this circuit are derived and the loss of signal amplitude due to restricting the signal to the first pair of side bands, the harmonic distortion and the limiting action of the arrangement are computed and discussed.

Electromagnetic-Hydrodynamic Waves

H. Alfven (*Kgl. Tekniska Hogskolan*, Stockholm)

The above article is reported in the Oct. 3, 1942 issue of *Nature*, London. It is pointed out that if a conducting liquid is placed in a constant magnetic field, movement of the liquid gives rise to an electro-motive force which produces a current. This current in combination with the magnetic field results in a force acting on the liquid. An equation between the action of this force, the force due to the kinetic energy of the fluid particles and the pressure gradient is set up and it is concluded that a wave propagating in the direction of the magnetic field results.

It is claimed that these waves may be of importance in explaining the sunspot movements, the velocity of the waves in a field of 15 gauss

Frequency-following superheterodyne receiver

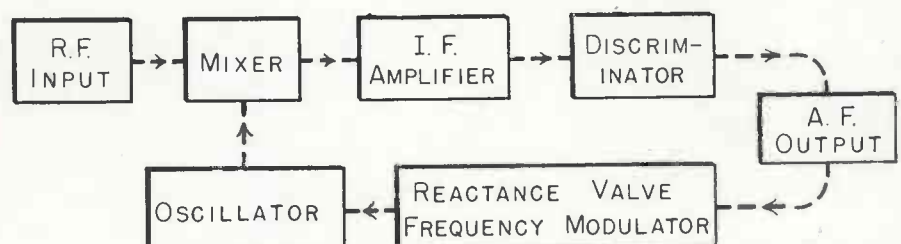

ELECTRONIC INDUSTRIES

January, 1943

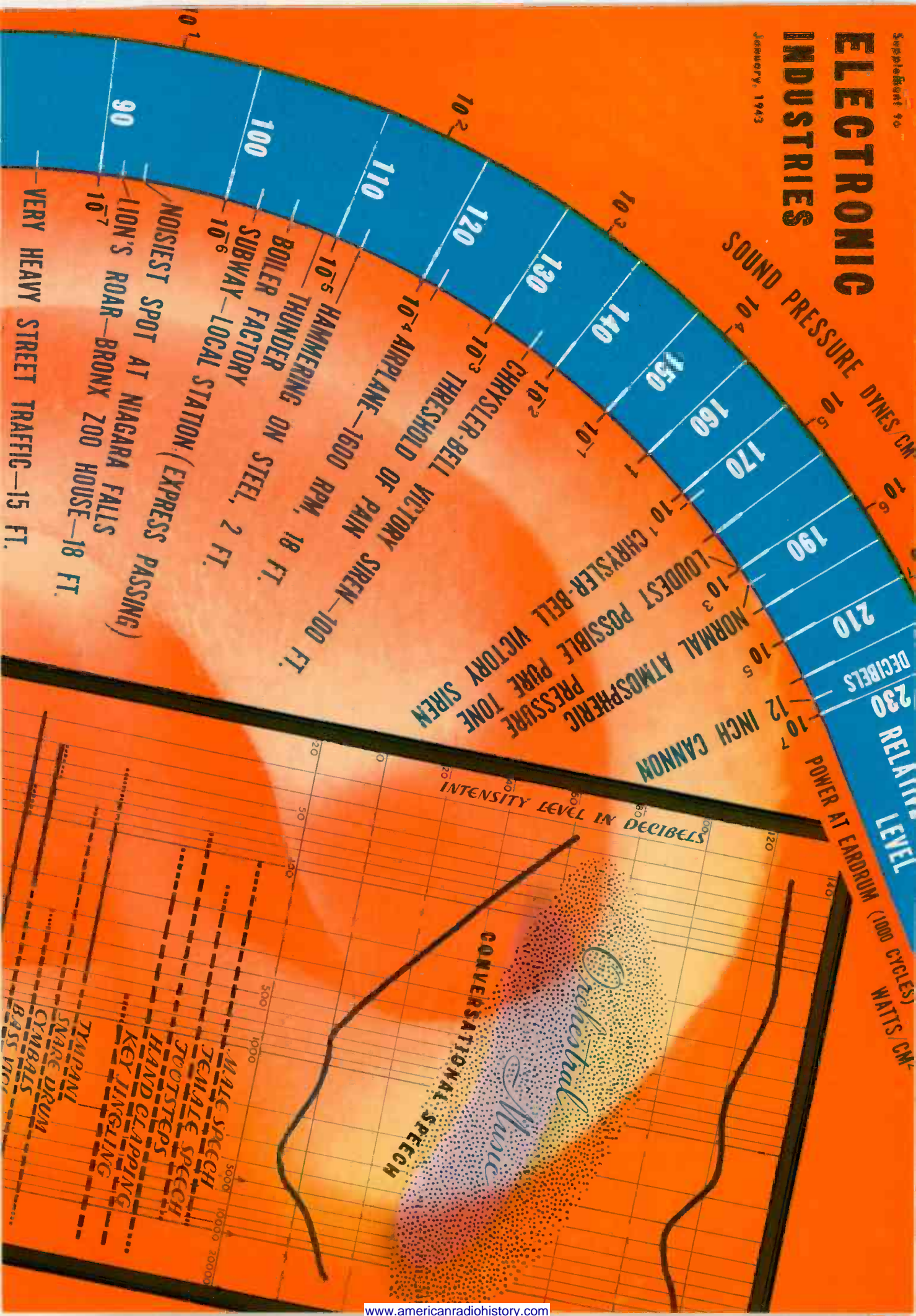

Frequency Recorders

A 20-page catalog, "Micromax Frequency Recorders and Indicators" has just been issued by Leeds & Northrup Co., 4934 Stenton Avenue, Philadelphia, Pa. Because of the ever-increasing interconnections of generating units, stations and systems, frequency control has become a vitally important factor in overall system regulation. Whether frequency is regulated automatically or by hand, Micromax instruments are claimed to provide the reliable measurements which are essential as a guide.

Measuring and Control Instruments

A 16-page bulletin, giving a condensed listing of its line of measuring and control instruments has just been issued by Wheelco Instruments Co., Harrison and Peoria Streets, Chicago. Unit construction of temperature controllers is described and illustrated, as well as the electronic principle for obtaining control without contact between measuring and control functions of the instrument. Also covered are remote controllers, combustion safeguard equipment and other instruments. Prices are given, as are numbers of complete catalog sections on equipment.

Pivot Manual

The Paralay Co., 600 South Michigan Ave., Chicago, announces the publication of a complete pivot manual covering specific and technical information on the application of Permium alloy pivots as used in all types of instruments. These pivots are designed to resist wear and vibration abuse, thereby forestalling instrument servicing and maintenance up-keep.

Motors

A catalog by the Carter Motor Co., 1608 Milwaukee Avenue, Chicago, shows and describes various motors to be used with radio receivers and transmitters, including ratings and diagrams.

Various dynamotors are shown and recommended for use in aircraft, marine, police and other mobile radio equipment. Permanent magnet magmotors are also available with extended shaft for hand generators, one of them with a continuous output capacity of 100 watts and designed for either one or two man operation. Several combinations of ac and dc voltages can be had. A machine for converting dc to ac is recommended for use in marine radio, testing equipment, small signs, amplifiers and phonographs.

Safety Switches

"Industrial Safety Switches"—bulletin 500, covers the design and listings of all types of Square D Co., 6060 Rivard St., Detroit, safety switches for industrial applications. Includes heavy duty industrial switches, general purpose double throw switches and manual motor starters in standard sheet metal and water-tight dust-proof and explosion-resisting cast enclosures.

Lignin

Lignin is a new plastic announced in a leaflet by the Western Electric Company 195 Broadway, New York. Manufactured from the sulphite water waste, it takes the place of phenol fibre in about two thirds of its former applications and so releases phenol fibre for war-essential products. Lignin paper sheets are conditioned to a definite moisture content, heated and subjected to high pressure, yielding a tough fibre board with the strength of steel. It possesses good electrical characteristics, is less corrosive than phenol fibre, and readily punchable.

Bonding Ring

The Cannon Electric Development Company, 3209 Humboldt Street, Los Angeles, Cal., has released a bulletin on its bonding ring. It is designed for bonding between electrical plug shell and wire shielding, and with either flexible conduit coupling nut or cable clamp.

Resistor and Relay

The Vitrohm strip resistor and midget metal base relays manufactured by Ward Leonard Electric Co., Mount Vernon, N. Y., are described in the company's bulletins No. 23 and 104, respectively.

WHAT NAVY REQUIRES

(Continued from page 44)

and for vacuum tubes headline the importance of reliability from the day the equipment goes into service until the day, perhaps years later, when the equipment will be retired. Reliability is achieved only through sound engineering and good materials. For many years our home broadcast receivers have sacrificed reliability to price, and have achieved brilliant performance more often than not through the use of selected "hot" tubes. The Navy does not want the set that plays the loudest, brings in the greatest distance, and then settles

ONLY WINCO GIVES YOU ALTI-TEMP DYNAMOTORS



Where complete dependability is essential . . . where efficient electric power is important . . . specify WINCO DYNAMOTORS! WINCO DYNAMOTORS are built for all types of service . . . for operating temperatures ranging from -40° to $+65^{\circ}$ Centigrade.

COMPACT
LIGHT WEIGHT
MINIMUM A.C. RIPPLE
LOW VOLTAGE REGULATION

These are only a few of the quality features in WINCO DYNAMOTORS.

WINCO DYNAMOTORS are regularly available in standard outputs and sizes . . . special WINCO DYNAMOTORS can be designed to meet your exact need. Our complete free Advisory Engineering Service is yours without obligation—why not consult us?

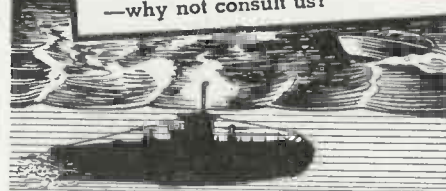

The Dynamotor designed to insure maximum efficiency at all operating altitudes and temperatures.

WINCO DYNAMOTORS
WINCHARGER CORPORATION
SIOUX CITY IOWA

Temperature 60°C

Catalog Number	TYPE 1590				Type
	10,000 kc.	3000 kc.	1000 kc.	300 kc.	
1590-217					
1590-218	16.	20.	15.		
1590-219	16.	20.	15.		
1590-220	18.	20.	17.		
1590-221	18.	20.	18.		
	18.	23.	20.		
1590-222					1
1590-223	18.	25.	22.		1
1590-224	18.	25.	22.		1
1590-225	18.	25.	22.		1
1590-226	18.	25.	22.		1
	18.	25.	22.		1
1590-227					1
1590-228	18.		22.		1
1590-229					1
1590-230					1
1590-231					1



Backed by the most complete CONTINUOUS SERVICE RATING DATA

• **Aerovox mica transmitting capacitors** are backed by exceptionally complete data on maximum current-carrying ratings at five different frequencies, in addition to capacity and test-voltage ratings. Such data is the accumulation of years of research and experience and exhaustive tests. Thus the unit best suited for given current at given voltage and frequency is selected quickly and precisely.

Good capacitors, plus good application data, account for the tremendous popularity which Aerovox transmitting capacitors enjoy today.

• DATA . . .

Be sure you have the Aerovox Transmitting Capacitor Catalog in your working library, if you are engaged in professional radio or electronic work. Write us on your business stationery.



down to the local stations when the tubes are replaced by a new complement from the corner store. Sound engineering can and does provide required sensitivity with rf tubes at the lower limit of mutual conductance and stable operation in the same set with rf tubes at the upper limit.

Workmanship

The Navy test specifications for vacuum tubes call for the highest standards of workmanship and materials, and for characteristics which are uniform within the narrowest limits which can be reasonably tolerated. Good engineering demands that equipment be designed with full consideration for the limits permitted on each vacuum tube characteristic. Equipment so designed will deliver required performance with all Navy tubes whether they be drawn from stores in Iceland or Australia.

The Navy test specifications set definite maximum operating conditions under which known tube life can be predicted. Tube replacements are made on definite schedules based on these predictions. It is common knowledge that overloading vacuum tubes greatly shortens tube life, and no competent engineer would release equipment for manufacture without thoroughly checking all vacuum tube operating conditions, at the maximum expected supply voltage, to be certain that the maximum tube ratings are not exceeded. Complete Navy vacuum tube specifications are on file at the office of each Inspector of Naval Material and at the plant of each manufacturer making tubes for the Navy. Individual specifications for given types are available from the Bureau to all Navy equipment contractors.

Approval tests

Before supplying vacuum tubes for use in Navy equipment or for Navy replacement stocks, a vacuum tube manufacturer must submit his product for Type Approval tests. These tests, conducted at the Naval Research Laboratory, provide for a most thorough examination of the electrical and mechanical characteristics of the tubes, a check on the accuracy of readings taken

WHAT

IS THE

STANDARD ATTENUATOR?

VARIATEN

VARIABLE ATTENUATORS

CINEMA ENGINEERING CO.
1508 WEST VERDUGO AVENUE
BURBANK, CALIFORNIA

★

Send for our new Catalogue,
listing the largest variety of
attenuators ever compiled.

★

Buy U. S.

War

Savings

Bonds

and

Stamps

★

by the manufacturer on the electrical characteristics and tests not ordinarily applied in production to determine the suitability of the tubes for Naval service. If the tubes pass these tests a Temporary Type Approval Certificate may be granted, followed by full approval on completion of life tests. A Type Approval Certificate covers only one type of tube and is subject to revocation at any time if tubes produced by the manufacturer show failures in service which indicate that quality standards have not been maintained.

Through the joint Army-Navy Preferred List, the Army and Navy provide a guide for the equipment designer in his choice of vacuum tubes. No tube, not on the Preferred List, may be used in Navy equipment without specific approval of the Bureau of Ships. The Preferred List will be revised with time to include new vacuum tube types having genuine merit. The natural objectives are to limit the number of tube types to those which provide required performance with maximum reliability. Any other course would necessitate the maintenance of impossible stocks of tubes at points throughout the entire world. Many new tubes have been developed within the past year for use in equipments so new that research and manufacture have been carried on simultaneously. The Bureau provides standardization of these new tubes at the earliest possible time so that those within the Bureau who are responsible for establishment of manufacturing facilities and procurement can bring the tubes into the equipment program on time.

Army-Navy cooperation

For many months the Signal Corps and the Navy have been working in the closest cooperation in full recognition of the common needs and objectives of the Armed Services. It is expected that both will soon utilize a common set of vacuum tube specifications, a common Type Approval system, and identical type designation markings.

The intent of the standardization of radio components is not to confine or restrict, but to relegate the selection of satisfactory compo-

PUT IT IN

Electronic

WRITING...

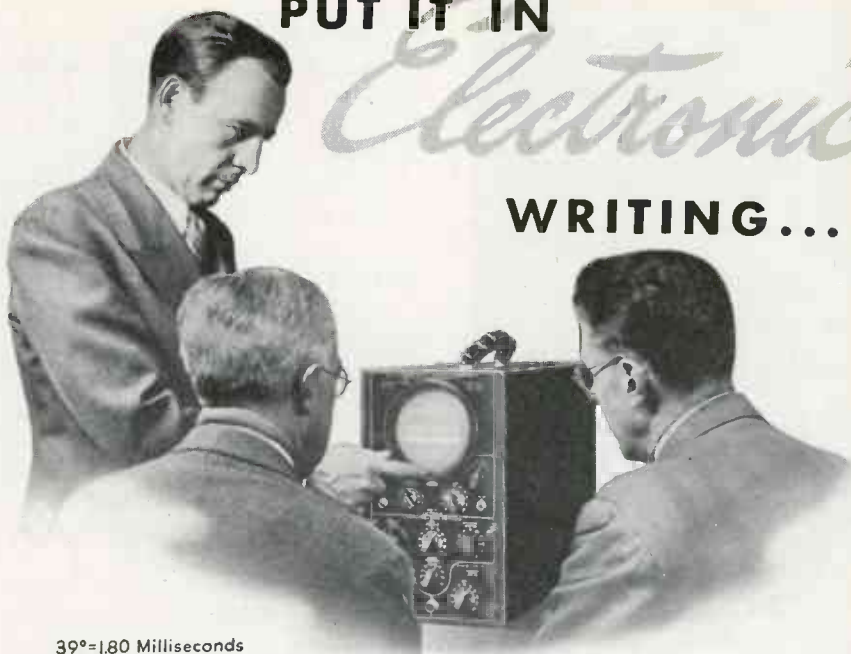

39°=1.80 Milliseconds

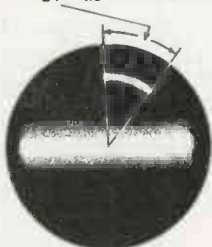

Oscillogram of the operation of a two-way snap-switch, accurately timed in milliseconds. The segment represented by the curved trace or arc, measures 39°, or the equivalent of 1.8 millisecond.

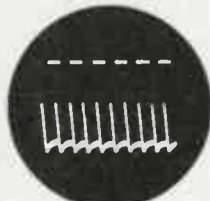

Oscillogram showing the precise wave form of the DuMont Variable-Frequency Stimulator for brain surgery and research. The remarkable uniformity of wave form and amplitude of the stimuli, is clearly disclosed here. Time interval: 1 millisecond.



Oscillogram of the response of a given amplifier to a 100 kilocycle square-wave signal. Such electronic writing provides the best evidence of actual performance.

★ Your report on electronic, radio, electrical and most technological functions should be put in *electronic writing* to save time, to be really explicit, to facilitate proper consideration and decision.

As an oscillogram vividly traced on the DuMont oscillograph screen, your presentation permits of either a quick grasp of the situation, or a highly detailed study if the finer intricacies of the wave form receive due consideration. A photograph of the oscillogram provides a permanent record.

Yes, it pays to put such matters in *electronic writing* these days. More and more presentations, explanations, discussions, are being handled that way.

And DuMont equipment, because of its versatility of application as well as sharp, detailed, brilliant, high-fidelity oscillograms, is now the recognized standard the world over.

★ Write for Literature . . .



**ALLEN B. DU MONT
LABORATORIES, Inc.**
Passaic · New Jersey
Cable Address: Wespexlin, New York

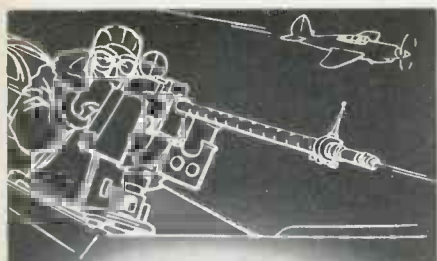

*Split second
action...or eternity*

★ Precious lives at stake—that was the predominant thought in the minds of Clarostat engineers while developing this split-winding power rheostat now used for a vital fire-control function in our fighting planes.

More specifically: 330° total rotation. Two resistance sections of matched resistance, equally disposed about a center section of virtually zero ohmage. Smooth transition from one section to another. Control must operate with very low torque and yet with positive contact pressure regardless of extremes in temperature, vibration, orientation.

This new control was produced in a few days, despite a new mold, new rotor and spring, three-winding strip. Today it is standard equipment. Typically a Clarostat assignment—and solution.



★ Send your problem to . . .



CLAROSTAT MFG. CO., Inc. - 285-7 N. 6th St., Brooklyn, N. Y.

nents to the field of routine thereby saving time and effort to be applied to other problems of design and development. Standardization must not interfere with present production and must be planned as to eventually result in increased production capacity.

RMA ENGINEERING DEPT.

(Continued from page 55)

concerned with the production of transmitting equipment. This has brought into the association an important group of transmitter manufacturers and has been reflected in the expanded organization of a Transmitter Section within the Engineering Department.

The establishment of the Transmitter Section and the redirection of the work of the Receiver Section with respect to military equipment have given the association an increasing opportunity to assist the war effort by application of the engineering practices of the industry to that effort.

Components

In this same period, the work of the Components Section was greatly enlarged to include the new materials and instrumentalities called into being by the turn of the industry to military equipment manufacture and, through the increased membership of the association, the personnel and activities of twenty odd committees of the Components Section was greatly enlarged.

Much progress has been made in standardization of components for purely military radio equipment. In order to centralize this work as well as to provide all possible support to the war effort, the entire structure of the Components Section of the Engineering Department was transferred to the Radio and Radar Branch of the War Production Board.

Plans ahead

There is every evidence that the RMA Engineering Department can do even more to assist the war effort. The executive committees of the Transmitter and Receiver Sections have established the details of a plan that will do much to assure that military radio equipment going to our far-flung forces, will

continue to provide the important communications required for successful military action over the ever-expanding ranges of climatic conditions.

The Vacuum Tube Section has also laid the ground plans for acceleration of the work of its committees in the ever-widening fields opened by the expanding military application of electron tubes and devices.

No one can soundly doubt that the work of America's radio industry is contributing in the greatest possible way to the ultimate success of the war effort.

50-KW FM AT W55M

(Continued from page 68)

drives a 3-kw unit and the 3-kw unit drives the final which is a 50-kw unit. The modulator, 250-watt unit, and 3-kw unit, power control panel, and high voltage rectifiers are mounted in the control room, while the high-voltage transformers and filter chokes are mounted outside in a transformer vault. The 50-kw amplifier is built in a special room that is completely shielded.

The antenna is a two-bay turnstile mounted atop a 200-foot tower built on a hill that has an elevation of 500 feet above the city of Milwaukee. Antenna power is fed from the transmitter to the base of the tower on two 3-inch concentric lines. At that point the phasing network is inserted, and eight 1½ inch lines carry on to feed the antenna arms.

Special FM programs

W55M is programmed independently of WTMJ, there being practically no duplication of programs between the two stations. W55M programs are predominantly musical. This is being done on the theory that through FM it is possible for the first time in radio history to reproduce fully the beauty and richness of music with absolute fidelity, with the expected result that many radio set owners not attracted to daytime serials will find in W55M programs an expression of their radio enjoyment.

The weekly W55M schedule includes 67 live shows. In building the live musical programs, the W55M production department has call on the 17 hours of weekly time for

which The Journal Company contracts with each of the 17 regular musicians on its radio staff. The recorded musical programs on W55M use only the finest high fidelity transcriptions.

The new Radio City home of WTMJ and W55M also plays an important part in improved service. When this studio building for The Milwaukee Journal radio stations was being planned, special attention was given to the exacting demands of FM. Consequently, acoustics and all other technical details have been engineered to give W55M programs probably the finest studio facilities of any FM station.

NEW UHF FIELDS

(Continued from page 64)

by which the tower operator can select landing directions at will.

This new radio instrument landing system has recently been installed at LaGuardia Airport in New York City and others are in process of installation in Cleveland, Atlanta, Chicago, Kansas City and Los Angeles. The system was developed jointly by the engineers of the Civil Aeronautics Administration, the Federal Telephone and Radio Corporation and The International Telephone and Telegraph Co., who is the manufacturing subsidiary in the United States, which manufactures and installs the equipment for the C.A.A.

The conclusions reached by these engineers have shown that ultra short waves may be successfully employed to provide both horizontal and vertical guidance as well as marker indication. Also that localizer courses must be much sharper than heretofore employed to avoid mutilation by reflection. The difference in amplitude of the patterns should be at least 2.2db., 1½ degrees off course in the majority of installations.

Localizer polarization must be pure to secure independence of the aircraft antenna characteristics and direction of approach of the plane to the localizer course. Then also, the localizer should be independent from the glide path in order to permit its installation well beyond the end of the runway so that it is not a hazard to the aircraft landing or taking off. Experience has indicated that the two



Communications Must Be Kept

The intricate maze of modern radio equipment needs frequent servicing . . . and good tools to speed the work. Spintite, the wrench that works like a screw driver is on the job from assembly lines to air bases . . . on ship and ashore.

Originally developed by Stevens Walden, Spintite features drilled shank, non-slip handle, precision machining . . . a tool to do a better job.

To speed your production or to facilitate servicing, we offer these wrenches produced by a plant with over 36 years experience in building good tools. Send for catalog showing complete range.



T51 Set at left, is popular for quick repairs. Chuck type handle, 7 Spintites with sockets ranging from 3/16" to 1/2", Reamawl, three screw drivers in various sizes. All in compact leatherette roll.

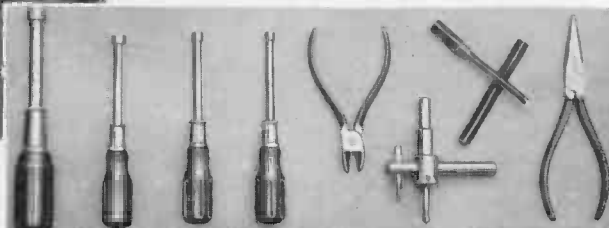

STEVENS WALDEN, INC.

477 SHREWSBURY STREET

WORCESTER, MASSACHUSETTS, U. S. A.



ZOPHAR WAXES

The strict specifications of the Navy, Army and Air force for communications equipment, call for the best and most carefully manufactured products.

ZOPHAR waxes and compounds are

being used and are meeting the rigid tests. We will appreciate your inquiries or will cooperate with you in solving your problems in potting, impregnating or insulating waxes.

ZOPHAR MILLS, INC.

Founded 1846

128-131 26th Street, Brooklyn, N. Y.

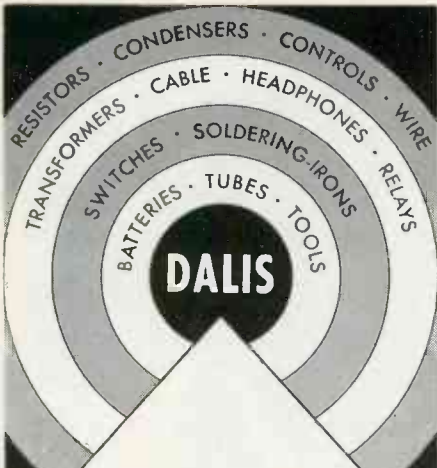

PRIORITY ORDERS

• Dalis Service has meant **SPECIALIZATION** in meeting radio and electronic parts requirements since 1925. The great number of items obtainable from **ONE** source has saved untold money, time and trouble for thousands of Dalis customers.

That **SPECIALIZATION** is today even more significant in expediting priority orders. Ample stocks on hand provide immediate shipment in many instances. And if items are not in stock, Dalis gets them to you in the shortest possible time.

Let Dalis **SPECIALIZED SERVICE** help you fill your urgent priority needs, with maximum efficiency, minimum delay.

• Write, wire or phone



H. L. DALIS, Inc.

Distributors of
RADIO & ELECTRONIC SUPPLIES
17 Union Square · New York, N.Y.

Phones: ALgonquin 4-8172-3-4-5-6-7

course localizer is inherently more simple to use than localizers with four or more courses. Likewise, it is advantageous for the glide path to be of a controllable type so that path shape can be adjusted during installation to accommodate the landing characteristics of aircraft.

PARTS — CIVILIAN SETS

(Continued from page 53)

ber of parts will be held to an absolute minimum in the forthcoming standards. This will further serve to reduce the amount of strategic materials kept in inventory by minimizing the stock of parts held by jobbers and service men.

For example, some 60 standard volume controls have been proposed to serve as replacements for the overwhelming majority of the thousands of different types used in home radio sets built during the past half dozen years, while 9 electrolytic and 11 paper capacitors have been proposed to do a similar job in the capacitor field. Similiar simplification and standardization in other radio parts such as transformers, chokes, coils, resistors, etc. is also included in the scope of the project now getting under way.

Tentative List of "Victory" Replacement Parts

REPLACEMENT CAPACITORS

A. Dry Electrolytic.		Rated Voltage
Capacity	Mfd.	
	100	25
	10-10	50
	20	150
	40-40	150
	10	450
	40-10	450
	40	450

Note: Capacitors are to be tubular type in cardboard containers. Dual units to have independent sections.

B. Paper.		Rated Voltage
Capacity	Mfd.	
	.01	120
	.05	120
	.1	120
	.0001	600
	.00025	600
	.0005	600
	.001	600
	.002	600
	.005	600
	.01	600
	.02	600
	.05	600
	.1	600
	.25	600

Note: Units to be wax impregnated in tubular cardboard containers.

REPLACEMENT VOLUME CONTROLS

A. Untapped Composition Type.		Taper reverse
Resistance		
10 M ohms		
25 M "		"
250 M "		audio
500 M "		audio
1 Meg.		audio
2 Meg.		audio

Goat
ELECTRONIC TUBE PARTS AND SHIELDS

Small Parts
of the **BIG WAR JOB!**

Goat Metal Stampings
INC.
Division of THE FRED GOAT CO., INC.
314 DEAN STREET, BROOKLYN, N. Y.

Goat has meant Accuracy since 1800

Putting 'em Thru the Mill!

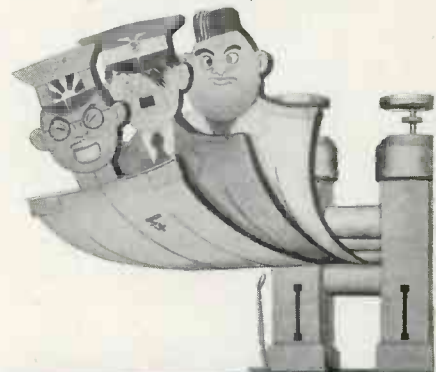

Strip for Action! Strip made from Wilbur B. Driver Co. special alloys! Strip that has so many essential war uses! As it is rolled through our mills, day and night, we know it will do its part in flattening the Axis! Consult us for your special alloy requirements in rod, wire, ribbon and strip — both hot and cold rolled.

WILBUR B. DRIVER CO.
NEWARK, NEW JERSEY

B. Tapped Composition Type.

Overall Resistance	Tapped Resistance
500 M ohms	150 M ohms
1 Meg.	300 M "
2 Meg.	15 M and 500 M ohms
2.25 Meg.	500 M and 1 Meg.

C. Wirewound.

Resistance	Taper
10,000 ohms	linear

Notes: Controls to be furnished with fixed 3/4 inch steel shaft with .156 inch flat. Shaft length 3 3/4 in. beyond 3/4 - 32 bushing, 3/8 in. long. Controls to be of "midget" or "junior" type, approximately 1 1/8 in. in diameter. No nuts, washers, ground terminals or bias resistors are to be furnished with controls. All controls to be suitable for use with adaptable switches.

Volume Control Switches.

- Single pole, single throw
- Double pole, single throw
- Single pole, double throw
- 4 pole, single throw, shorting

Note: Switches to be of adaptable type and have U.L. rating of not less than 1 amp, 250 v and 3 amps, 125 v.

RESISTOR LINE CORDS

- 180 ohms
- 350 ohms
- 600 ohms

**ELECTRONIC DEVICES
SPEED AIRCRAFT
PRODUCTION**

(Continued from page 46)

light from a source held constant by an electronic voltage regulator is projected through each spectral line to a sensitive photo-emissive tube, the output of which is amplified by a two stage compensating amplifier to operate a galvanometer. This densitometric reading gives a quantitative measurement of the desired element of sufficient accuracy for most purposes. Qualitative analysis, or the identification of the elements present in a sample, is accomplished by visual comparison of the spectrogram film or plate with a master plate showing predominant spectral lines of most of the elements. The images of both plates are highly magnified and projected on a built-in screen for the convenience of the operator.

An ARL-Dietert spectrograph in use at the Ranger Aircraft Engines plant makes daily spectrographic tests of every batch of raw material received. The results are compared with standardized tolerances allowable, to determine acceptance or rejection.

**Electronic devices
in combat flying**

Many radio and electronic accessories to fighting airplanes were described by UP's F. C. Oechsner, who reports on a day at Wright Field, Dayton, Ohio.

"In the laboratories I saw cameras whose lenses are operated automatically by photoelectric cells activated by flash bombs, portable

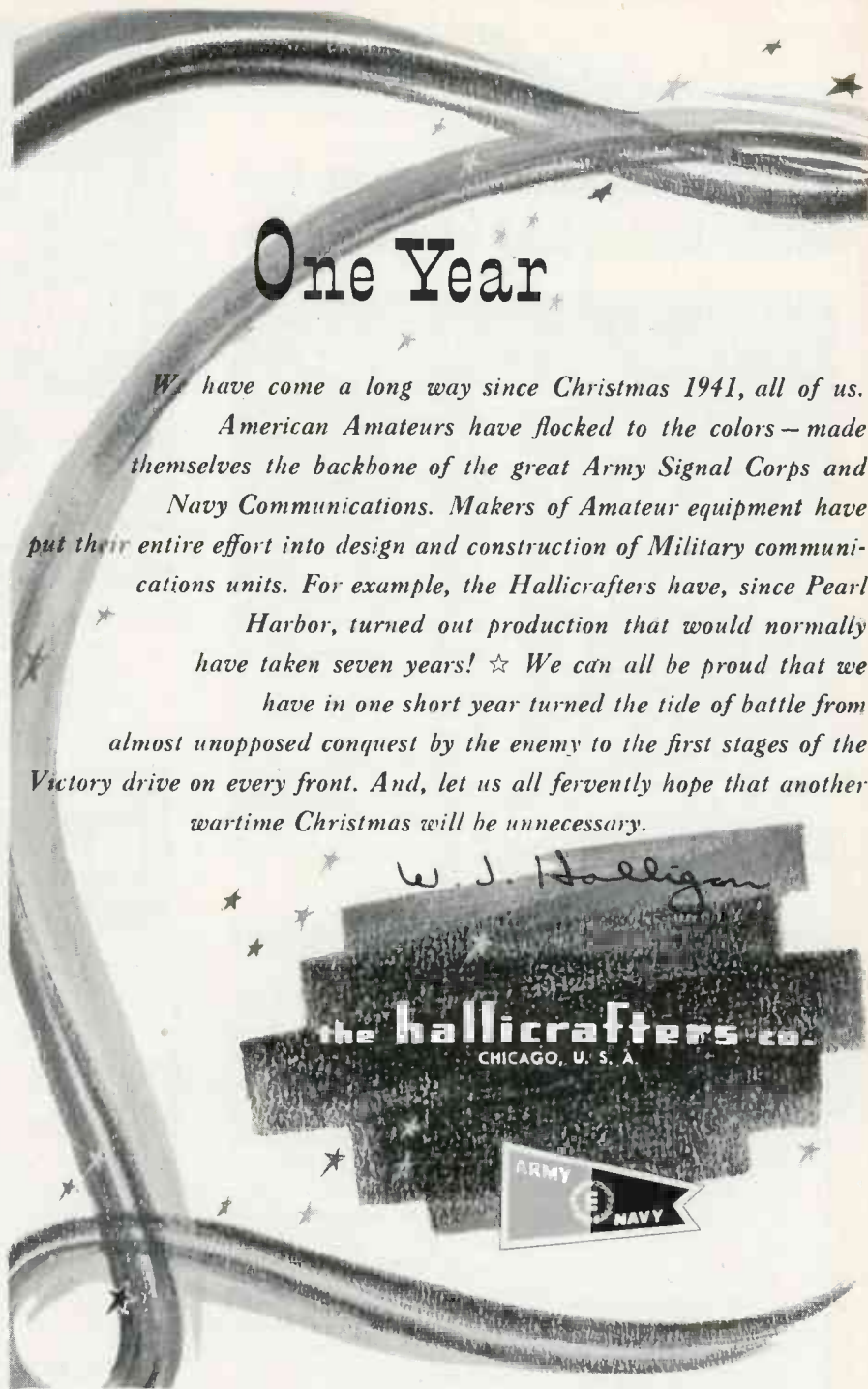

One Year

We have come a long way since Christmas 1941, all of us. American Amateurs have flocked to the colors — made themselves the backbone of the great Army Signal Corps and Navy Communications. Makers of Amateur equipment have put their entire effort into design and construction of Military communications units. For example, the Hallicrafters have, since Pearl Harbor, turned out production that would normally have taken seven years! ☆ We can all be proud that we have in one short year turned the tide of battle from almost unopposed conquest by the enemy to the first stages of the Victory drive on every front. And, let us all fervently hope that another wartime Christmas will be unnecessary.

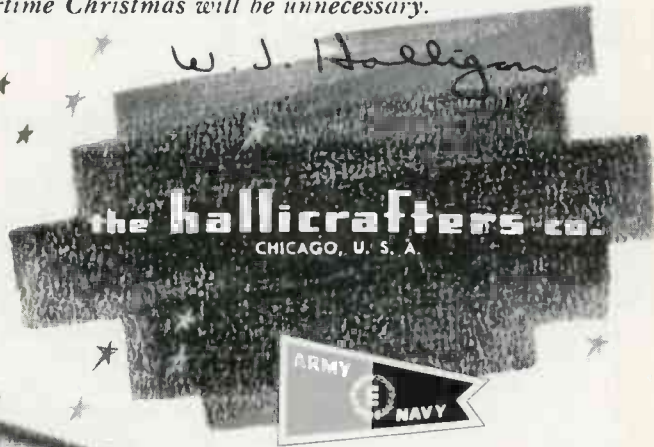

POSITION VACANT

Electronic engineer for development of special gas tubes. Experience in gas tubes necessary. Permanent position. Good salary. Location, New York, Box 100, Electronic Industries 480 Lexington Ave., New York.

FOR SALE

50 KW oscillator parts. 3-phase power supply, controls, condensers, accessories, rectifier tubes. 893 oscillator tube. All brand new. Box 222, Electronic Industries, 480 Lexington Avenue, New York.



Speed up War-Time Development Work
With this Coast-to-Coast Emergency Service

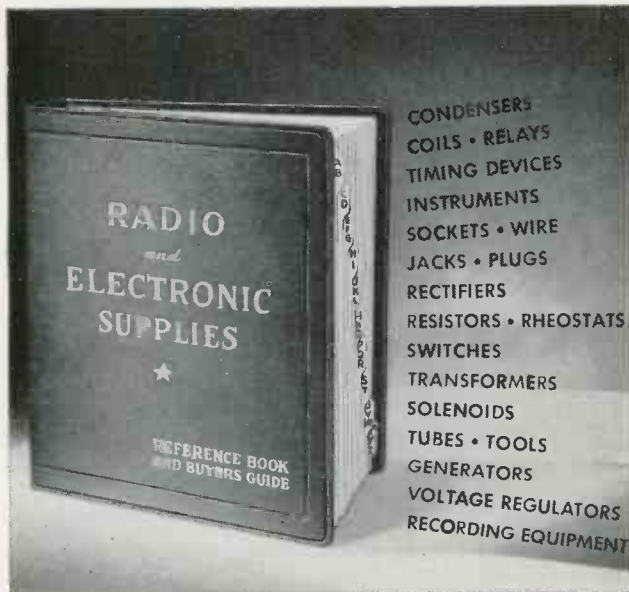

CONDENSERS
COILS • RELAYS
TIMING DEVICES
INSTRUMENTS
SOCKETS • WIRE
JACKS • PLUGS
RECTIFIERS
RESISTORS • RHEOSTATS
SWITCHES
TRANSFORMERS
SOLENOIDS
TUBES • TOOLS
GENERATORS
VOLTAGE REGULATORS
RECORDING EQUIPMENT

On Radio and Electronic Supplies!

NO ordinary, run-of-the-mill service, this! It's a *special* department, manned by technicians who *know* radio and electronic products . . . men whose job it is to ship you whatever you need without a moment's delay. These *special* departments and staffs, together with very large and diversified stocks, are maintained by *each* of the strategically located distributors shown below. You'll save hours or days of precious time by a phone call or mailed order to the one nearest you. We believe this service is a vital contribution to the war effort. . . . an invaluable aid to development and maintenance workers in our country's electrical war industries. Make use of it now! Or, write for **FREE** Reference Book & Buyer's Guide listing thousands of radio and electronic items.

A FEW OF THE MANY ITEMS LISTED . . .

Condensers, Coils, Relays, Timing Devices, Instruments, Wire, Sockets, Jacks, Plugs, Rectifiers, Resistors, Rheostats, Tubes, Solenoids, Switches, Transformers, Tools, Generators, Voltage Regulators, Recording Equipment, Sound Equipment.

WRITE OR PHONE YOUR NEAREST DISTRIBUTOR

TERMINAL RADIO COMPANY

85 Cortlandt St., New York, N. Y.
Telephone: WOrth 2-4416

WALKER-JIMIESON, INC.

311 South Western Ave., Chicago, Ill.
Telephone: Canal 2525

RADIO SPECIALTIES COMPANY

20th and Figueroa Sts., Los Angeles, Cal.
Telephone: Prospect 7271

**Beat DELIVERY DEADLINES
WITH DIALCO
PILOT LIGHT ASSEMBLIES**

DIALCO

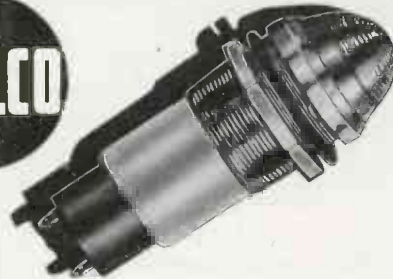

**DIALCO DELIVERS THE GOODS ON TIME,
AND EXACTLY AS ORDERED . . .**

That is a fact for which Government Depts. and many manufacturers have expressed praise and gratitude. (The letters are in our files.)

Leaders in this field, our line of **WARNING** and **SIGNAL PILOT LIGHT ASSEMBLIES** includes 265 Assemblies and parts, plus hundreds of special assemblies to order.

Your needs may be met by our stock models. Or if your's is a special problem, we will help you solve it quickly.

Samples and blueprints will be submitted promptly.

**FOR
QUICK
ACTION
WRITE
Now!**

DIAL LIGHT CO. of America INC.

90 WEST STREET • NEW YORK, N. Y.

RAFTS & SEAGULLS



Keep paddling—furiously—in every channel of the war effort. Don't wait for a stray seagull. Providence may not think we're all as worthy as Rickenbacker.



ERWOOD SOUND EQUIPMENT CO.

222 W. ERIE STREET

CHICAGO, ILLINOIS

development tents which can be dropped by parachute, and photographic plates so sensitized that the detailed picture of an entire city can be printed on a surface not more than four inches across.

"At luncheon one day the radio apparatus in our room began to give out an SOS signal at regular intervals," Oechsner said. "We were told that the signals came from a rubber boat 'lost at sea' near by. We found it, just south-east of the radio laboratory. Four doughty airmen were sitting in it awaiting our arrival. One of them held in his lap the radio device, a small hand dynamo which automatically ground out an SOS when cranked. It could be converted at will into a Morse hand-sender or an electric-light blinker.

"There were other gadgets on display and under test—an automobile which gave out a 'homing' signal for airplanes in the field, portable television sets, the latest type of 'walkie-talkie,' or portable wireless telephone.

"We saw a radio-controlled model plane with a wing spread of about six feet, its engine propelling it at 100 miles an hour. It was equipped with a radio-controlled parachute to let it float gently down to earth, since landing still is too complicated an operation for remote control. A small boy's dream of delight, the little plane is militarily useful as a target for anti-aircraft practice."

HEATING AIRCRAFT PARTS

(Continued from page 52)

indicates the average "cost per kw" at various powers.

Operating costs in equipment of this type are made up mainly of tube replacement and power costs. Since there are no moving parts other maintenance costs are negligible. Contrary to some statements, the useful life of the equipment is long and will most likely be terminated by obsolescence rather than wear. Depreciation, therefore, can only be based on some arbitrary figure such as that used for tax purposes.

Basis of figures

In order to gain some idea of operating costs, a number of equipments of various powers were an-



Meissner employees are justifiably proud of their "E" emblem... the symbol of a job well done.

WAR MEMO

To keep the Axis from our shores, keep after that "10% of gross payroll" goal in War Bonds, through the Payroll Savings Plan!

On Land...
PINCOR Products
Keep 'Em Winning!

DYNAMOTORS • CONVERTERS • GENERATORS • D. C. MOTORS • POWER PLANTS • GEN-E-MOTORS
PIONEER GEN-E-MOTOR
 CHICAGO, ILLINOIS
 EXPORT ADDRESS: 25 WARREN STREET, N. Y. N. Y. CABLE: SIMONTRICE, NEW YORK

STABILIZED A. C. VOLTAGE
UP TO 25 KVA

INSTANTANEOUS ACTION **NO MOVING PARTS**

When a precision electrical device or a critical process is powered from an AC line, a Raytheon Voltage Stabilizer will permanently eliminate all of the detrimental effects caused by AC line voltage fluctuations. Made for all commercial voltages and frequencies, single or three phase.

Raytheon's twelve years of experience in successfully applying the Stabilizer to hundreds of perplexing voltage fluctuation problems is at your service. It will pay you to take advantage of our engineering skill.

Write for Bulletin DL-48-71 JE describing Raytheon Stabilizers.

RAYTHEON MANUFACTURING CO.
 100 Willow Street WALTHAM, Massachusetts

alyzed and the results graphed. In this calculation average tube life was assumed as 5000 hours (which is a reasonable estimate of the life of present day tubes in this service). Power was assumed to cost 1c per kilowatt hour. Depreciation was figured on the basis of 25,000 hours of operating life (approximately three years at 24 hours a day, or nine years at 8 hours a day). The overall cost, of course, is simply the total of depreciation, tube and power costs.

It is worth noting that these costs can only be assumed to hold for the present period. Simplifications in design, improvements in tube construction and other factors which can be quite clearly foreseen will undoubtedly lead to lower first cost and lower operating cost. However, it is apparent that even on the basis of the costs indicated, there are many present-day jobs on which this type of equipment can easily be justified from the cost standpoint.

Advantages of rf

The more obvious advantages of the radio frequency method follow from the fact that in this method heat is caused to be generated simultaneously and uniformly throughout the whole body of the wood. This means that neglecting losses) the whole block of wood comes up to temperature evenly. It also means that the time required for a given increase in temperature is independent of the thickness of the wood.

These effects are in marked contrast to those which occur with other methods of heating. In all other methods, heat which originates outside the wood as, for instance, in steam plattens) must travel into the wood by conduction. As a result, the outer layers of the wood come up to temperature much more quickly than the interior. Moreover, the time required to heat a section of wood depends entirely on the thickness. In the case of thick sections this becomes very long.

Curves herewith on time of heating are based mainly on experimental measurements made on various sections of wood heated by the rf method. For each time-thickness relation a set of three

curves is given. This is necessary because in this method of heating the temperature gradient depends on the conduction losses—and these losses depend to some extent on the set up used. The three typical set ups illustrated by these curves are: first, for the case where the material is directly against the faces of a large cold press; second, where the material is clamped between relatively thin metal plates which are exposed to air; and third, for the case where a thin layer of heat-insulating material (such as press board) is placed between the material and the press or between the electrodes and the press.

The curves for the cold press set up are shown dotted. The large mass of metal acts as a "sink" and the outer surface of the wood never rises above ambient temperature. The curves for the thin electrodes are shown broken. In this case the surface temperature rises to some extent and the gradient is less sharp. The curves for the set up where heat insulation is used are shown solid. These are purely indicative since in this case the gradient depends on the amount of heat insulating material. The curves shown are for measurements made with insulating sheets having one-eighth the thickness of the wood itself.

Merits over steam

Comparing the curves for the two methods, the most striking feature is the fact that for a 1-inch thickness the radio frequency process gives a time cycle of 4 minutes (to 280 deg.), where the steam plate method requires some 15 minutes to bring the center to the same temperature. Further increase in the thickness of the wood makes the discrepancy even greater since (as can be seen from the above formula) the time increases as the square of the thickness. Moreover, the steam plate time cycles are fixed and there is no way of appreciably shortening them. On the other hand, the time cycles required for radio frequency heating depend entirely on the power used. The curves were calculated on the basis of a power to give 5 watts per cu. in. of material. Increasing this to 10 watts per cu. in. would cut the time in half. The temperature

Solve Voltage Variation
PROBLEMS IN AIRCRAFT, TANKS, ETC.

WITH

AMPERITE

BATTERY CURRENT & VOLTAGE REGULATORS

Features:—

1. Amperites cut battery voltage fluctuation from approx. 50% to 2%.
2. Hermetically sealed — not affected by altitude, ambient temperature, or humidity.
3. Compact, light, and inexpensive.

Now used by U. S. Army, Navy, and Air Corps.

Send us your problem.

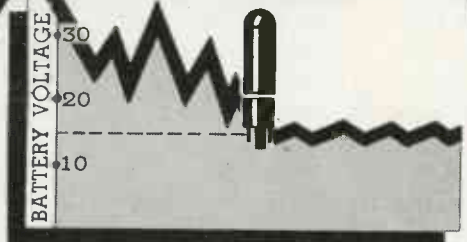

VOLTAGE OF 24V BATTERY & CHARGER VARIES APPROX. 50% WITH AMPERITE VOLTAGE VARIES ONLY 2%

50%

2%

AMPERITE COMPANY • 561 Broadway, New York, N. Y.
In Canada: Atlas Radio Corp. Ltd., 560 King St. W., Toronto

Cable: Alkem, New York

AUTOMATIC FREQUENCY RESPONSE RECORDER

A true War Worker, will save valuable hours of skilled men!

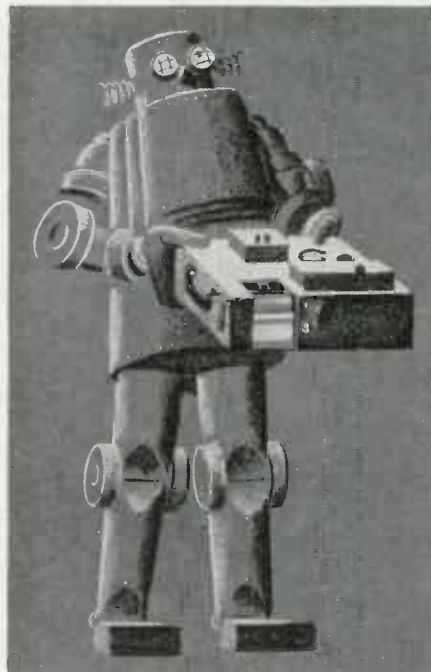

- It provides continuous frequency response characteristics of any audio apparatus on a standard chart, in an absolutely automatic manner.

- The Frequency Response Recorder among its many other applications, measures voltage and current, loudness and vibration.

- Complete technical information available in our bulletin "SOUND ADVANCES".

SOUND APPARATUS COMPANY
150 West 46th Street • New York City

would then be raised to 280 deg. in two minutes. Whether or not this quick cycle would sufficiently set the glues is a moot point. Some authorities on glue believe that the glue must be held at fairly high temperature for at least two or three minutes.

When the comparative time cycles for thicknesses greater than 1 inch are considered it is immediately evident that the advantages of radio frequency are enormous. As indicated, the time to heat thicker sections by radio frequency is the same as the time for the 1 inch section. This statement is true, of course, only if the power per cu. in. of wood is kept constant; in other words, the total power increased as the thickness. If the total power is held constant, then the time varies directly as the thickness. In the steam plate method, on the other hand, the time varies as the square of thickness. This leads directly to the second important advantage — viz., thick sections which by older methods had of necessity to be cold-glued can now be hot-glued. This means they can

be produced more quickly — and since higher-temperature setting glues can be used, they can be made better.

Avoids "case-hardening"

Still another advantage is evident when the shape of the heating-time curves is considered. In the hot-plate method the outer layers of wood are at a high temperature for a very considerable length of time. As a result these tend to dry out and a degree of "case hardening" sets in. In critical sections such as aircraft parts this is very objectionable. Sometimes the wood must be "conditioned" after the gluing by being wet on the outside to increase the moisture content of the outer layers. With rf this drying out does not occur, even where the cycle is fairly long, because the temperature gradient has a slope the reverse of that which would cause such an effect.

An important advantage where new press installations are considered is the fact that the presses themselves can be of much cheaper design, since the massiveness asso-

ciated with steam plates and multiple openings is done away with. Moreover, the use of radio frequency makes it much easier to use "hot" gluing in conjunction with very large presses and presses of unwieldy dimensions. Presses designed originally for cold gluing are readily adapted for hot gluing.

Compregwood benefits

When making compregwood parts radio frequency has another very important advantage. This is the fact that since the whole mass of wood is heated uniformly the compression takes place uniformly. The contrast with what takes place when using a steam die only is very marked. In the latter instance the outer plies, of course, heat up very quickly and the resin in them begins to set up. Compression must, therefore, be started immediately. However, at this point the interior of the wood has not even started to heat. As a result the compression is very non-uniform and terrific internal stresses result. Such stresses can be partially relieved by very long cooking periods, but even then



**No Gremlins
NEED APPLY!**

ALLIANCE dynamotors and band-switch motors are engineered to stand up and take it. They give it back, too, twenty-four hours a day in Alaska and Africa, from Greenland to Gibraltar — gremlins or no gremlins.

Built with quality materials, by precision methods to exact specifications, Alliance dynamotors and band-switch motors are dependable. Their sound engineering gives economy in construction and operation.

The everyday use of Alliance motors under today's conditions proves "no motors better built or better engineered."



DEPENDABILITY proved by constant service under all conditions.

PRECISION proved by the wide variety of exacting performance.

ECONOMY proved by low initial cost and reliable operation.

ALLIANCE MANUFACTURING CO.
ALLIANCE, OHIO

NEW PLASTIC MODEL MICROPHONES



NEW MODELS OF CU-1 AND NEW 1700 TYPE. HALF THE WT. OF FORMER MODELS. CRISP, CLEAR, CLEAN SPEECH. COMPLETE INSULATION. NO CORROSION. ALSO JACKS, SWITCHES, PARTS AND PLUGS PL-68, PL-54, PL-55, JK-26, JK-48 & PL-291 (companion plug) AND SW-141.

AVAILABLE TO U. S. PRIME AND SUB-CONTRACTORS AND FRIENDLY FOREIGN COUNTRIES. PRIORITIES REQUIRED. IMMEDIATE INITIAL SHIPMENT; BAL. TO MEET ALL SCHEDULES. EXPORT . . . BERT HASSLER (Fraxar and Co.), ANNAPOLIS HOTEL, WASHINGTON, D. C.

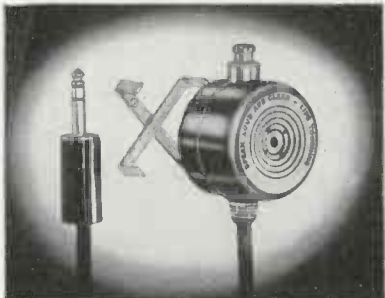

UNIVERSAL MICROPHONE CO., LTD.
Inglewood, California U. S. A.

results are often unsatisfactory. Direct comparisons made between similar sections done with and without radio frequency show that in the latter these have been 90 per cent or more eliminated.

All of the above advantages are cited on the basis of work which has actually been done. In considering the use of radio frequency for making curved surfaces such as fully-stressed wing or fuselage elements, it should be noted that this is something which apparently has not yet been done in production. Should the radio frequency process be found feasible, there would, of course, be marked advantages. While the autoclave method appears to be the most satisfactory found to date, it is unquestionably cumbersome, time-consuming and expensive. Use of rf might conceivably eliminate the cost of the autoclave, greatly reduce the time cycle, the quantity of jigs required, the number of operations and the inconveniences attendant on the present process.

Situation changed

With all the advantages of radio frequency one wonders why it has not been more widely adopted. The answer seems to lie in the fact that there are definite problems in applying it to other than simple jobs. These problems have been too much for wood engineers to solve by themselves and—at least until very recently—radio engineers have not been interested.

The present plywood plane and glider program has changed this situation overnight. The importance of this work, plus the necessity for quantity production, plus the desirability of using phenol glues have caused a sudden demand for radio frequency equipment. This has revived the interest of radio engineers and they are now tackling these application problems on a wide front.

SHORT WAVE RADIATION

(Continued from page 73)

whether this is a surface separating two different dielectrics, separating a dielectric and a conductor or just a surface of discontinuity in the geometry of a system as in our case the plane $z = e$ appears to be.

There are now two possibilities of adjustment at the end $z = e$, speak-

REMLER

Plugs and Connectors



ARMY SIGNAL CORPS SPECIFICATIONS

- Also PL—PLP—PLQ and PLS Plugs
- M Type Connectors
- M Type Caps
- FT Type Fittings

Quantity Prices Quoted
on receipt of Delivery
Schedules

Manufacturers of Communication Equipment
SINCE 1918

REMLER COMPANY, Ltd. • 2701 Bryant St. • San Francisco, Calif.

LITTELFUSE *Beryllium Copper* FUSE CLIPS STAND THIS TEST:



Above: Actual movie photo of screwdriver test shows Littelfuse Be. Cu. Clip's instant return to perfect form.

To right: Same test with phosphor bronze clip. Note deformed condition after test.

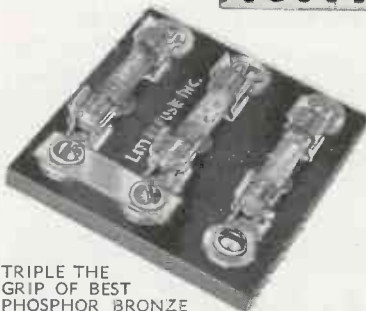
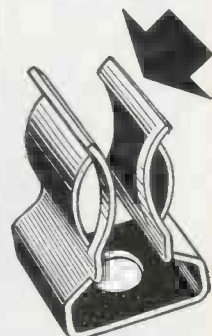

TRIPLE THE
GRIP OF BEST
PHOSPHOR BRONZE

SPRING QUALITIES OF STEEL

Other characteristics of Littelfuse Be. Cu. Fuse Clips are: extremely high tensile strength, modulus of elasticity, resistance to heat, corrosion, and vibration; fatigue resistance well above 40,000 p.s.i. Technical Bulletin of full engineering details available.

Littelfuses are made for every instrument use. For high and low voltage, all types and sizes; fuse clips, mountings, etc.

LITTELFUSE INC. 4732 RAVENSWOOD AVE.
CHICAGO • ILLINOIS

Need
Intelligible
Communications?

Use a

TURNER Microphone

TURNER Microphones are specifically designed and engineered to faithfully reproduce gradations of volume, amplifying only the vibrations received by the diaphragm, without adding any of the harmonics.

A. Turner Cardioid 101

Here's the unit that stymies all background noises. The 2-element generator produces true cardioid characteristics and offers the best features of both the dynamic and velocity. Where the going is tough and acoustic conditions practically impossible, a Turner Cardioid can handle the job. Available in Standard, De Luxe and Broadcast Models.

B. Turner U9-S Multiflex

This ONE Turner unit offers your choice of 4 impedances—50, 200 or 500 ohms or hi-impedance, simply by twisting the switch. A dynamic microphone that's free from peaks and holes from 40 to 9000 cycles. Be sure you can handle ANY job with Turner U9-S.

C. Turner 211 Dynamic

Utilization of a new type magnet structure and acoustic network permits outstanding performance characteristics with the 211. High frequency range has been extended and extreme lows raised, to compensate for over-all deficiencies in loud speaker systems.

D. Turner Han-D

Hold it, hang it, or mount it on standard desk or floor stand, this Turner is HAN-D. Positive contact slide switch permits off-on operation. Will not blast from close speaking. Crystal or Dynamic.

If You Have a Priority Rating

WRITE, explaining your communications problems and we can help you select the Turner Microphone best suited to your needs. Also, information on how to make your present Turner Microphones and Equipment give longer, better service.

FREE Turner Microphone Catalog, with complete information and prices on Turner Microphones and Equipment. Write:

Crystals Licensed Under Patents of The Brush Development Co.

THE TURNER CO.

CEDAR RAPIDS, IOWA

ing in a rather general way:

1. The arriving electromagnetic field, being essentially transverse i. e. electric and magnetic field vectors in planes perpendicular to the conductor surfaces, is completely reversed, and not a trace of this transverse field continues beyond $z = e$. This satisfies, of course continuity of the tangential field components in the boundary plane, but it also makes $i = v = 0$ there, and, in fact, erases completely current and voltage all along the line since it superimposes the exact opposite of what we originally had, namely the source reversed in sign. Obviously, this is not reasonable.

2. If the conventional transmission line theory gives correct results far from the ends, as has been verified experimentally many times, then close to the ends there must be superimposed new and different field configurations which help to satisfy the boundary conditions. This seems to be the reasonable compromise. One calls, then, the transverse electromagnetic field the "principal mode" of the transmission, and the superimposed correction fields the "complementary modes" of transmission⁽³⁾. This leads, then, to a partial reflection of the transverse electromagnetic field and the part that is not reflected is "radiating" out into free space beyond the transmission line, as well as from the end section of the line. And this is where finally frequency comes into its own right: the higher the frequency and the wider the spacing d , the larger will be the radiation from the open end, which is a good reminder of experiences with Lecher-wires⁽³⁾.

Now the same situation must hold for the sending end since basically the same dilemma arises. The only difference is, though, that at the sending end a source of power is located, which causes distortion of the otherwise transverse field of the transmission line such that the source and source end of the line radiate into space. The radiation at the sending end, is however, guided by the transmission conductors and for the most part bent around to give flow of power along the line towards the terminal end. This is pictorially shown in Fig. 3.

Appendix

Maxwell's field equations take the most concise form in vector notation, namely

$$\text{curl } H = \gamma E + \epsilon \frac{\partial E}{\partial t}$$

$$\text{curl } E = -\mu \frac{\partial H}{\partial t}$$

where γ , ϵ , μ , are respectively electric conductivity, absolute dielectric constant, and absolute permeability. For free space (vacuum) in the Giorgi system of units, one has

$$\epsilon_v = \frac{10^{-9}}{36\pi} \text{ farad/m}$$

$$\mu_v = 4\pi 10^{-7} \text{ henry/m}$$

and the relative numerical values of dielectric constant and permeability

$$\text{are defined by } \epsilon_r = \frac{\epsilon}{\epsilon_v} \quad \mu_r = \frac{\mu}{\mu_v}$$

The conductivity γ is measured in mho/m electric field strength E in volt/m and magnetizing force H in amperes/m.

In the Cartesian x-y-z system, the one usually most familiar to readers, the equations of Maxwell take the longer form

$$\left. \begin{aligned} \frac{\partial H_z}{\partial y} - \frac{\partial H_y}{\partial z} &= \gamma E_x + \epsilon \frac{\partial E_x}{\partial t} \\ \frac{\partial H_x}{\partial z} - \frac{\partial H_z}{\partial x} &= \gamma E_y + \epsilon \frac{\partial E_y}{\partial t} \\ \frac{\partial H_y}{\partial x} - \frac{\partial H_x}{\partial y} &= \gamma E_z + \epsilon \frac{\partial E_z}{\partial t} \end{aligned} \right\}$$

and

$$\left. \begin{aligned} \frac{\partial E_z}{\partial y} - \frac{\partial E_y}{\partial z} &= -\mu \frac{\partial H_x}{\partial t} \\ \frac{\partial E_x}{\partial z} - \frac{\partial E_z}{\partial x} &= -\mu \frac{\partial H_y}{\partial t} \\ \frac{\partial E_y}{\partial x} - \frac{\partial E_x}{\partial y} &= -\mu \frac{\partial H_z}{\partial t} \end{aligned} \right\}$$

In the transmission line system, where only a plane configuration is considered, one would take $E_z = H_z = 0$ and consequently find simpler expressions.

REFERENCES

1. S. A. Schelkunoff: "The Impedance Concept and Its Application to Problems of Reflection, Refraction, Shielding, and Power Absorption," Bell Syst. Tech. J., Vol. 17, pp. 17-48, Jan. 1938.
2. H. H. Skilling: "Fundamentals of Electric Waves" (book), John Wiley and Sons, New York, 1942, p 118 etc.
3. J. R. Carson: "The Guided and Radiation Energy in Wire Transmission," J. A.I.E.E., Vol. 43, pp. 906-913, October 1924.

To Be Continued in February

CARTER SOLVES YOUR *Dynamotor* PROBLEMS



For many years, Carter Dynamotors have been a familiar part of the specifications of leading Communication Equipment Manufacturers, Police Departments, Government Agencies, etc. May we suggest you submit your Dynamotor requirements too, and see for yourself the reason for this recognized preference.

The latest catalog of Carter Dynamotors, Converters, Permanent Magnet Generators and Dynamotors, and special rotary equipment will be sent upon request.

Carter Motor Co.
Chicago, Illinois

RADIO AND ELECTRONIC PARTS DELIVERED ... Now!

FOR ALMOST a quarter of a century Lafayette has maintained quick, accurate delivery service from complete stocks—one or a thousand units, there is no order too small or too large.

ENGINEERS: Get acquainted with Lafayette's immediate delivery service—send in your order now to this ONE CENTRAL SUPPLY DEPOT for those hard to find parts—radio, electronic, or sound. Draw on the thousands of varied items now in Lafayette's stockrooms. You can depend on Lafayette quality.

FREE! 130 page illustrated CATALOG containing thousands of items indexed for quick reference—order your copy now! Address 901 W. Jackson Blvd., Chicago—Dept. 1J3

Camera Fans: Photographic Equipment at lowest prices. Write for FREE PHOTOGRAPHIC CATALOG.

LAFAYETTE RADIO CORP.

901 W. JACKSON BLVD., CHICAGO, ILL. 265 PEACHTREE STREET, ATLANTA, GA.

TEST with



**SECONDARY
FREQUENCY
STANDARD**

Used by U. S. Army Signal Corps

- ★ Exact Frequency Measurement 100 to 60,000 K.C.
- ★ The Ideal Crystal Controlled Signal Generator for I. F. or R. F. Alignment Purposes.
- ★ Checks Factory Test Oscillator Accuracy.
- ★ Checks Receiver and Transmitter Calibration. Unexcelled for setting Electron-coupled Oscillator Transmitter Frequency to Close Tolerance, thereby eliminating Spot Frequency Crystals.
- ★ Signal at Every 1000 K.C. provides Rapid Location of 100 and 10 K.C. Beats.
- ★ Ideal for Portable Use. Weight 12 lbs. Size 5" x 8" x 8 1/2".

Operates on 115, 130, 150, 220, and 250 volt 25 to 60 cycle A.C. Supplied complete with Bliley 100 and 1000 K.C. duo-frequency crystal and one 6V6 oscillator, one 6N7 harmonic generator, one 6L7 harmonic amplifier and one 6X5 rectifier. (Price Complete \$39.50)

Write for details

FRED E. GARNER CO.

Radio and Marine Equipment
45 E. Ohio St. Chicago, Ill.

Advertisers' Index

	Page	Page	
AEROVOX CORP.	104	INTERNATIONAL RESISTANCE CO.	83
ALLIANCE MFG. CO.	114	LAFAYETTE RADIO CORP.	117
ALLIED RADIO CORP.	99	LAPP INSULATOR CO., INC.	3
AMPEREX ELECTRONIC PRODUCTS	2	LENZ ELECTRIC MFG. CO.	11
AMPERITE CO.	113	LITTELFUSE INC.	115
BENDIX AVIATION CORP.	Cover 4	LORD MFG. CO.	8
BRADLEY LABORATORIES, INC.	94	MALLORY & CO., INC., P. R.	Cover 2
CAPITOL RADIO ENGINEERING INSTITUTE	90	MEISSNER MFG. CO.	111
CARDWELL MFG. CORP., ALLEN D.	97	MILLEN MFG. CO., INC., JAMES	88
CARTER MOTOR CO.	117	MURDOCK MFG. CO.	93
CENTRALAB	85	NATIONAL UNION RADIO CORP.	99
CINEMA ENGINEERING CO.	104	OHMITE MFG. CO.	79
CLAROSTAT MFG. CO., INC.	106	PHILCO RADIO & TELEV. CORP.	18
CORNELL DUBILIER CORP.	10	PIONEER GEN-E MOTOR	112
CRYSTAL PRODUCTS CO.	21	PRODUCTION ENGINEERING CORP.	96
DAVEN CO.	Cover 3	RADIO SYNDICATE GROUP	110
DALIS INC., H. L.	108	RAYTHEON MFG. CO.	30, 112
DE JUR-AMSCO CORP.	17	R. C. A. MFG. CO., INC.	7, 60, 61
DEUTSCHMANN CORP., TOBE	1	REMLER CO., LTD.	115
DIAL LIGHT CO. OF AMERICA, INC.	110	SHURE BROTHERS	28
DRIVER CO., WILBUR B.	103	SNYDER MFG. CO.	99
DUMONT LABORATORIES INC., ALLEN B.	105	SOLA ELECTRIC CO.	26
EITEL-MCCULLOUGH, INC.	31	SOUND APPARATUS CO.	113
ELECTRONIC MECHANICS, INC.	23	SPRAGUE SPECIALTIES CO.	9
ELECTRO-VOICE MFG. CO., INC.	13	STANDARD TRANSFORMER CORP.	19
ERIE RESISTOR CORP.	12	STEVENS WALDEN, INC.	107
ERWOOD SOUND EQUIPMENT CO.	110	STRUTHERS DUNN, INC.	16
FARNSWORTH TELEV. & RADIO CORP. ...	87	SUN RADIO CO.	118
FELKER MFG. CO.	5	THORDARSON ELECTRIC MFG. CO.	4
FORMICA INSULATION CO.	6	TRIPLETT ELECTRICAL INSTRUMENT CO.	20
GALVIN MFG. CORP.	24	TUNGSOL LAMP WORKS, INC.	27
GARNER CO., FRED E.	118	TURNER CO.	116
GENERAL CERAMICS & STEATITE CORP..	15	UNITED ELECTRONICS CO.	29
GENERAL RADIO CO.	95	UNITED TRANSFORMER CO.	32
GOAT METAL STAMPINGS INC.	108	UNIVERSAL MICROPHONE CO., LTD.	114
GOULD-MOODY CO.	25	U. S. TREASURY	92
GUARDIAN ELECTRIC MFG. CO.	14	UTAH RADIO PRODUCTS CO.	81
HALLICRAFTERS CO.	109	WARD LEONARD ELECTRIC CO.	22
HYTRON CORP.	65	WINCHARGER CORP.	103
INSTRUMENT RESISTORS CO.	98	ZOPHAR MILLS	107

While every precaution is taken to insure accuracy, we cannot guarantee against the possibility of an occasional change or omission in the preparation of this index.

ELECTRONIC INDUSTRIES

Advertising Rates

	1 t.	3 t.	6 t.	12 t.
One page	\$230.00	\$225.00	\$220.00	\$210.00
Two-thirds page	153.33	153.33	150.00	146.67
One-half page	115.00	115.00	112.50	110.00
One-third page	76.67	76.67	76.67	75.00
One-quarter page	57.50	57.50	57.50	56.25
One-sixth page	38.33	38.33	38.33	38.33
One-eighth page	28.75	28.75	28.75	28.75

Covers, preferred positions, inserts, color, bleed, etc.—rates on request.

Next issue, FEBRUARY. Closing date, proofs furnished, January 27; without proofs, January 30.

Subscription rate—1 year, \$3.00; 2 years, \$5.00.

Subscriptions accepted only from those who are professionally active in manufacturing, laboratories, Government and communications services.

Circulation, this issue . . . 15,000 copies

CALDWELL-CLEMENTS, Inc.

Publishers of

NEW YORK
480 Lexington Ave.
Telephone
PLaza 3-1340

ELECTRONIC INDUSTRIES
ELECTRONIC YEAR BOOK
& ENGINEERING DIRECTORY
INDUSTRIAL ELECTRONICS
RADIO RETAILING TODAY
THE RADIO YEAR BOOK

CHICAGO
201 N. Wells St.
Telephone
Randolph 9225

THIS BOOK

FREE



800
Page
Buying
Directory

To
**AUTHORIZED
PURCHASING AGENTS
ENGAGED IN WAR EFFORT!**

Send for Your Copy — Today!

**Everything in
RADIO PARTS
and INDUSTRIAL
ELECTRONIC EQUIPMENT**

Here, at SUN, you will find the solution to your urgent needs—a complete, single source of supply under one roof! Thousands of standard electronic parts and equipment in stock for all industrial research, development or production requirements. Save time by coming to SUN first! Write today on your company letterhead for free copy of our 800 page buying directory. Quantity is limited—so hurry! Address Box EX-1.

New York's Oldest Radio Supply House
—Telephone BARclay 7-1840—

SUN RADIO CO.
212 FULTON ST.
NEW YORK, N. Y.



to DISTANT HORIZONS

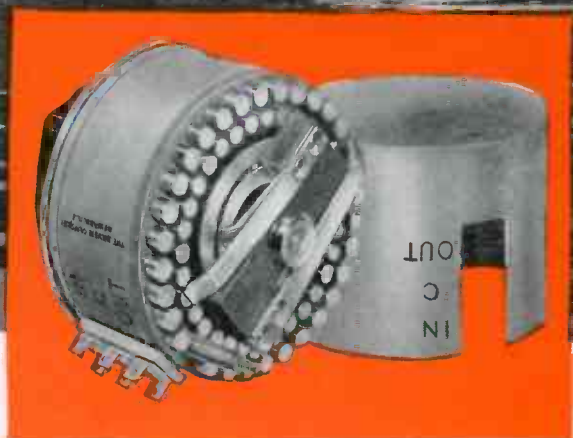

DAVEN engineers, like Pan American clippers poised for flight to distant lands, are charting future applications for our products.

Tomorrow, DAVEN equipment will reach beyond the confines of the Broadcast, Sound Picture, Television and Electrical fields . . . into the expanding industrial applications that are appearing on the electronic horizon.

A DAVEN catalog should be in your reference files. We list the most complete line of precision attenuators in the world; "Ladder", "T" type, "Balanced H" and potentiometer networks — both variable and fixed. Also, more than 80 models of Laboratory Test Equipment as well as Super DAVOHM precision type wire-wound resistors, with accuracies from $\pm 1\%$ to $\pm 0.1\%$. A request will bring this catalog to you.

THE DAVEN COMPANY

158 SUMMIT STREET

NEWARK, NEW JERSEY

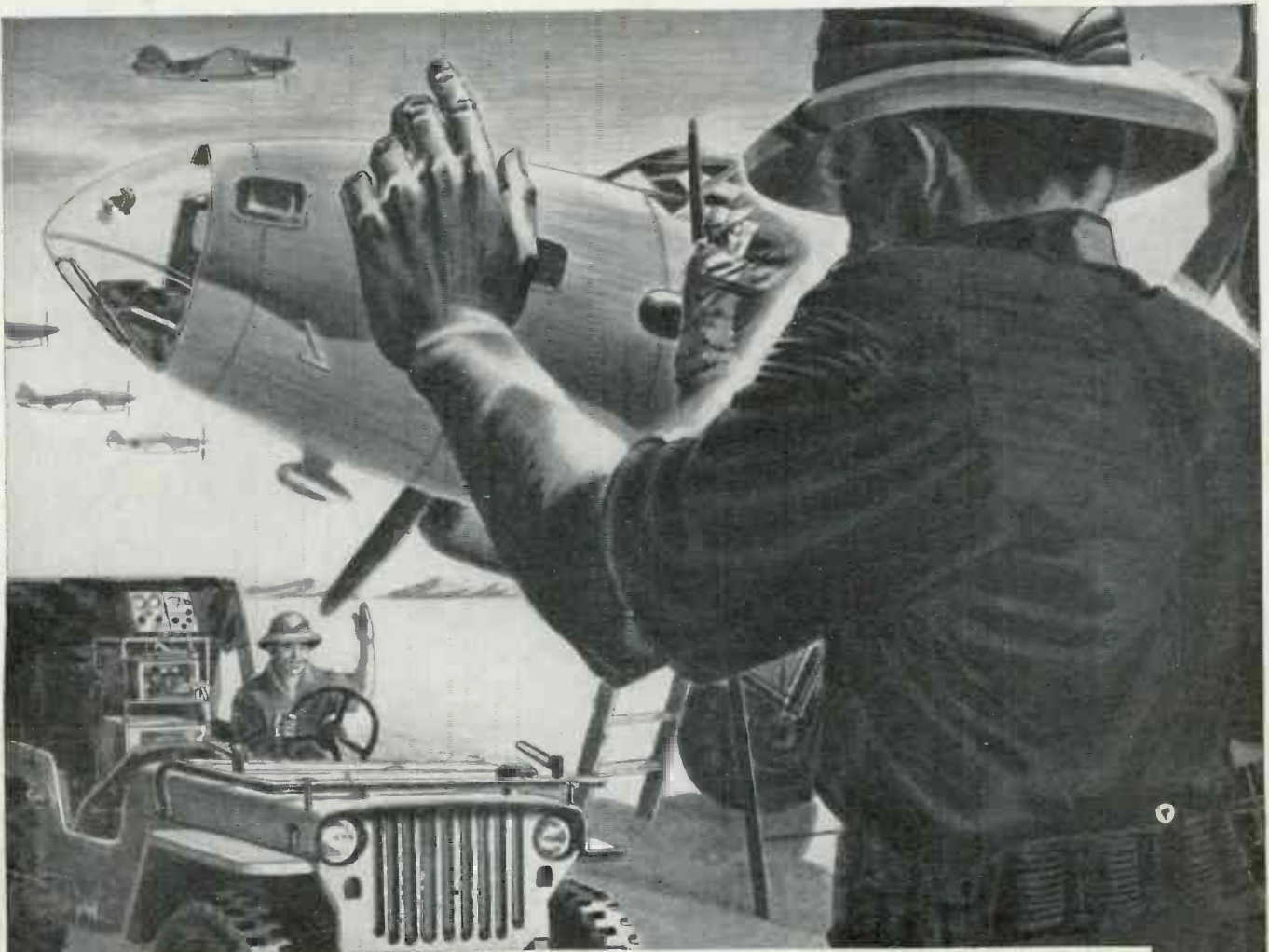

RADIO SERVICE MAN OUT OF *Cairo*

Somewhere in Africa . . . or Iran, India, China . . . an American bomber returns to its base. Tomorrow, it will fly again . . . provided essential repairs are made tonight.

For this and numerous other such situations, BENDIX-RADIO Service Men are ever alert. Stationed at such

centers as Cairo, Karachi and Kuning, within reach of advance bases of United Nations forces, these trained engineers are available at all times to render expert service.

Here on the home front, too, men and women of BENDIX-RADIO are doing their bit towards victory.

Products of BENDIX-RADIO are important members of "The Invisible Crew" . . . the precision instruments and equipment which 25 Bendix plants from Coast to Coast are speeding to our fighting crews on World Battle Fronts.



BENDIX RADIO DIVISION